



iSBC 204 UNIVERSAL FLEXIBLE DISKETTE CONTROLLER

Full compatibility with iSBC 80 and iSBC 86 Single Board Computers

Direct compatibility with most single-density, soft-sectored standard- and mini-size flexible diskette drives

Software supported by RMX/80 Real-Time Multitasking Executive disk file system

DMA input/output allows single board computers to process in parallel with diskette transfer operations

Programmable track-to-track access, head-settling, and head-load times

On-board data separation logic

Read, write, verify, and search on single or multiple sectors

Single +5V supply

The Intel iSBC 204 Universal Flexible Diskette Controller is a single board universal diskette controller capable of supporting virtually any software-sectored, single density diskette drive. The standard iSBC 204 Controller can control two drive surfaces (two single sided drives or one doubled sided drive). With the addition of a second (optional) Intel 8271 circuit, up to four drives can be supported. In addition to the standard IBM 3740 formats, the controller supports sector lengths of up to 4096 bytes plus mini-size drive formats. The iSBC 204's wide range of drive compatibility is achieved without compromising performance. The operating characteristics (track-to-track access, head-load, and head-settling times) are specified under user program control. The controller can read, write, verify, and search either single or multiple sectors.

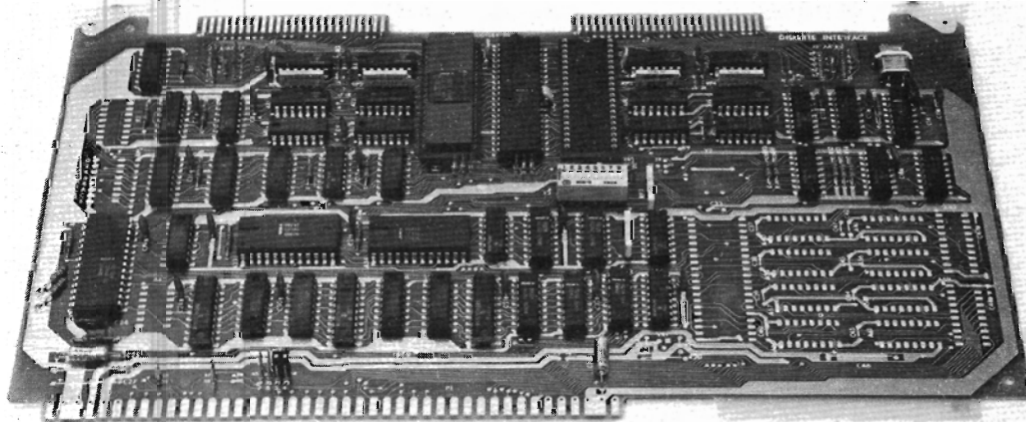

FUNCTIONAL DESCRIPTION

Intel's 8271 Floppy Disk Controller (FDC) circuit is the heart of the iSBC 204 Controller. On-board data separation logic performs standard FM encoding and decoding, obviating external separation circuitry at the drive. Diskette data transfers are DMA (direct memory access) through an on-board Intel 8257 DMA controller circuit which manages DMA transfers and signals the master iSBC processor on completion of the transfer. A block diagram of the iSBC 204 Controller is shown in Figure 1.

Universal Drive and MULTIBUS Compatibility

Because the iSBC 204 Controller has universal drive compatibility, it can be used to control virtually any standard- or mini-sized single density diskette drive. Moreover, the iSBC 204 Controller fully supports the microcomputer industry standard MULTIBUS system bus and can be used with any single board computer or system compatible with Intel's bus. Because the iSBC 204 Controller is programmable, its performance is not compromised by its universal drive compatibility. The track-to-track access, head-load, and head-settling characteristics of the selected drive model are program specified. Data may be organized in a fully compatible IBM 3740 sector format, in sectors up to 4096 bytes in length, or in formats compatible with the mini-sized diskette drives.

Interface Characteristics

Expandability — Each standard iSBC 204 Controller includes a single 8271 FDC circuit capable of supporting two drive surfaces. Optionally the iSBC 204 may be expanded to support four single-sided (or two double-sided) drives with the insertion of a second 8271 circuit into an on-board socket.

Simplified Interface — The cables between the iSBC 204 Controller and the drive(s) may be either low cost, flat ribbon cable with mass termination connectors or twisted pair conductors with individually wired connectors. An on-board, cross-connect matrix allows optional drive control and status signals to be connected while maintaining pin-to-pin compatibility.

Programming

The powerful 8271 FDC circuit is capable of executing high-level commands that simplify system software development. The device can read, write, and verify both single and multiple sectors. CRC characters are generated and checked automatically. Up to two tracks on each surface may be designated "bad" and logically removed from the diskette.

Sector Scanning — Scan commands permit sectors to be searched for a specified data pattern or "key". During scan operations the pattern image from memory is continuously compared with a sector or multiple sectors

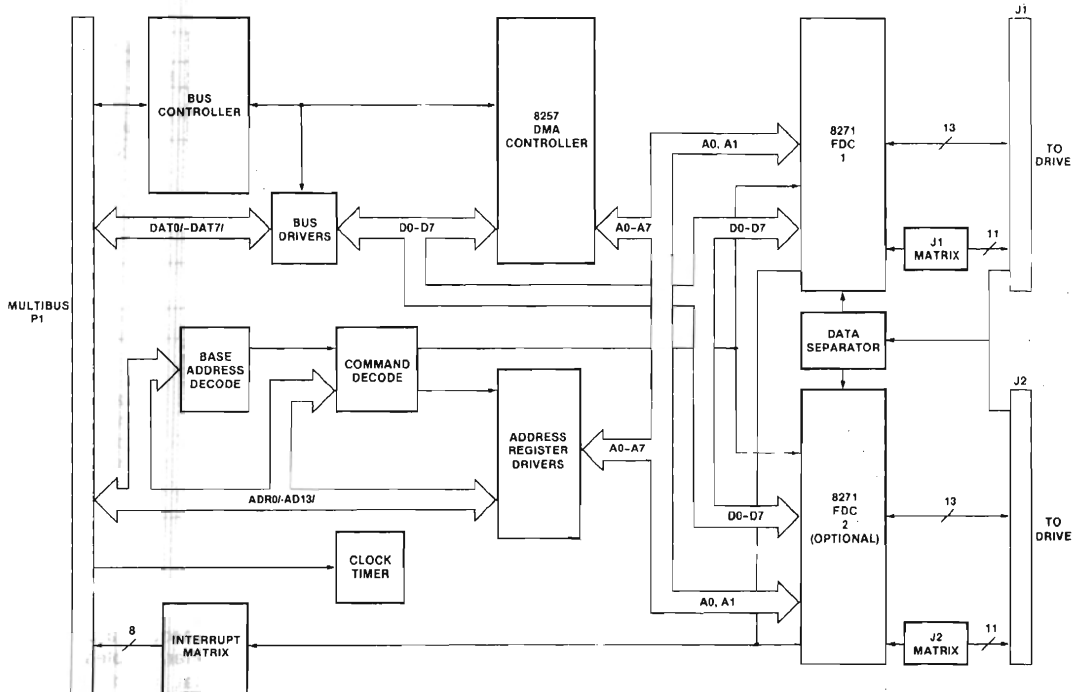

Figure 1. iSBC 204 Universal Flexible Diskette Controller Block Diagram

read from the diskette. No CPU intervention is required until a match is found or all specified sectors have been searched.

Program Initiation — All diskette operations are initiated by standard input/output (I/O) port operations through an iSBC single board computer. System software first initializes the controller with the operating characteristics of the selected drive. The diskette is then formatted under program control. For subsequent transfers, the starting memory address and transfer mode are specified for the DMA controller. Data transfers occur in response to commands output by the CPU.

Data Transfer — Once a diskette transfer operation has been initiated, the controller acts as a bus master and transfers data over the MULTIBUS at high speed. No CPU intervention is required until the transfer is complete as indicated either by the generation of an interrupt on the bus or by examination of a "done" bit by the CPU.

RMX/80 Real-Time Executive Software Support

The iSBC 204 Controller is supported by the disk file system of RMX/80, Intel's real-time executive. Files are named symbolically and may be created, deleted, or changed.

Data may be accessed sequentially or directly. An unlimited number of files can be open simultaneously and multiple tasks may read the same file concurrently. A listing of service functions included under RMX/80 is shown in Table 1. Since RMX/80 is a modular system which allows functions to be implemented selectively, memory requirements are reduced considerably. Diskettes processed under RMX/80 are compatible with Intel's ISIS-II system supervisor.

Function	Operation
Open	Prepares a file for processing.
Read	Transfers data from open file to memory.
Write	Transfers data from memory to open file.
Seek	Enables direct access.
Close	Terminates processing of file.
Delete	Removes file from directory, releases its space.
Rename	Changes name of file.
Attrib	Changes attribute of a file.
Format	Initializes a new disk.
Load	Reads a file of executable code into memory.
Disk I/O	Performs basic I/O operations.

Table 1. Services Available Under RMX/80

SPECIFICATIONS

Compatibility

CPU — Any iSBC MULTIBUS computer or system mainframe.

Drive — Single density, standard and mini-sized diskette drives. The standard iSBC 204 Controller supports two single-sided drives or one double-sided drive. By adding an (optional) 8271 FDC, four single-sided or two double-sided drives may be supported. The following drives are known to be compatible:

Standard Size	Mini Size
CDC 9404	PERTEC FD200
GSI 110	SHUGART SA400
MEMOREX 550	WANGCO 82
MEMOREX 552 (dual-sided)	
SHUGART 800	
SHUGART 850 (dual-sided)	
WANGCO 76S	
PERTEC 650 (SD/DD, DBL. Head)	

Diskette — Unformatted IBM Diskette 1 (or equivalent single-sided); unformatted IBM Diskette 2 (or equivalent double-sided); unformatted Shugart SA104 Diskette (or equivalent mini).

Data Organization and Capacity (Standard Size Drives)

	IBM Format			Non-IBM Format		
	128	256	512	1024	2048	4096
Bytes per sector	128	256	512	1024	2048	4096
Sectors per track	26	15	8	4	2	1
Tracks per diskette	77			Up to 255		
Bytes per diskette (77 tracks)	256,256 (128-byte sector) 295,680 (256-byte sector) 315,392 (512-byte sector)			315,392		

Drive Characteristics

	Standard Size	Mini Size
Transfer rate (KB/sec)	250	125
Disk speed (RPM)	360	300
Track-to-track access (programmable)	1 to 255 ms in 1 ms steps	2 to 510 ms in 2 ms steps
Head settling time (programmable)	0 to 255 ms in 1 ms steps	0 to 510 ms in 2 ms steps
Head load time (programmable)	0 to 60 ms in 4 ms steps	0 to 120 ms in 8 ms steps

Equipment Supplied

iSBC 204 Controller

Reference Schematic

Controller-to-drive cabling and connectors are not supplied with the iSBC 204 Controller. Cables can be fabricated easily using either flat ribbon cable or twisted pair conductors with commercially available connectors as described in the iSBC 204 Hardware Reference Manual.

Optional Equipment

8271 Flexible Diskette Controller Circuit — Adding a second 8271 device to the fully tested circuit on the iSBC 204 Controller allows four drive surfaces to be supported.

Physical Characteristics

Width — 6.75 in. (17.15 cm)

Height — 0.5 in. (1.27 cm)

Length — 12.0 in. (30.48 cm)

Shipping Weight — 1.75 lb (0.80 kg)

Mounting — Occupies one slot of iSBC system chassis or iSBC 604/614 cardcage.

Electrical Characteristics

Power Requirements — 5.0V ($\pm 5\%$), 2.5A max

Environmental Characteristics

Temperature — 0°C to 55°C (operating); -55°C to +85°C (non-operating)

Humidity — Up to 90% relative humidity without condensation (operating); all conditions without condensation or frost (non-operating)

Reference Manuals

9800568 — iSBC 204 Diskette Controller Hardware Reference Manual (NOT SUPPLIED).

9800522 — RMX/80 User's Guide (NOT SUPPLIED).

Reference manuals are shipped with each product only if designated SUPPLIED (see above). Manuals may be ordered from any Intel sales representative, distributor office or from Intel Literature Department, 3065 Bowers Avenue, Santa Clara, California 95051.

ORDERING INFORMATION

Part Number	Description
SBC 204	Universal Flexible Diskette Controller