

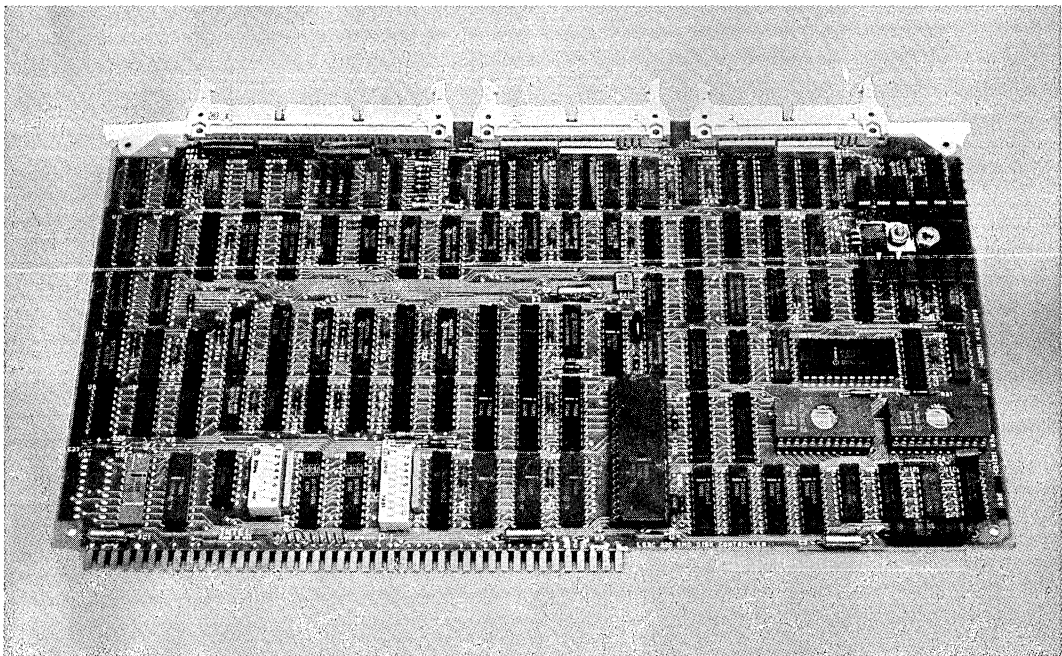

iSBC™ 220 SMD DISK CONTROLLER

- Controls up to four SMD interface compatible disk drives
- 12 MB to 2.4 GB per controller
- Compatible with all iSBC™ 80, iSBC™ 88, and iSBC™ 86 Single Board Computers
- Intel® 8089 I/O Processor provides two high speed DMA channels as well as controller intelligence
- Software drivers available for iRMX™ 86 and iRMX™ 88 operating systems
- On-board diagnostic and ECC
- Full sector buffering on-board
- Capable of addressing 1 MB of system memory
- SMD interface available on 14" Winchester, CMD, SMD and large fixed-media drives

The iSBC 220 SMD Disk Controller brings very large mass storage capabilities to any iSBC 80, iSBC 88, or iSBC 86 MULTIBUS system. The controller will interface to any disk drive conforming to the industry standard SMD interface. Using simplified cable connections, up to four drives may be connected to the iSBC 220 Controller Board to give a total maximum capacity of 2.4 gigabytes. The Intel 8089 I/O Processor simplifies programming through the use of memory-based parameter blocks. A linked list technique allows the user to perform multiple disk operations.



The following are trademarks of Intel Corporation and may be used only to describe Intel products: CREDIT, Index, Intel, Insite, Inteltec, Library Manager, Megachassis, Micromap, MULTIBUS, PROMPT, UPI, µScope, Promware, MCS, ICE, iRMX, ISBC, ISBX, MULTIMODULE and ICS, and the combination of MCS, ICE, ISBC, ISBX or ICS, and a numerical suffix. Intel Corporation assumes no responsibility for the use of any circuitry other than circuitry embodied in an Intel product. No other circuit patent licenses are implied.

FUNCTIONAL DESCRIPTION

Full On-Board Buffer

The iSBC 220 SMD Controller contains enough on-board RAM for one full sector buffering. The controller is designed to make use of this buffer in all transfers. The on-board sector buffer prevents data overrun errors and allows the iSBC 220 SMD Controller to occupy any priority slot on the MULTIBUS.

ECC

High data integrity is provided by on-board Error Checking Code (ECC) logic. When writing sector ID or data fields, a 32-bit Fire code, for burst error correction, is appended to the field by the controller. During a Read operation, the same logic regenerates the ECC polynomial and compares this second polynomial to the appended ECC. The ECC logic can detect an erroneous data burst up

to 32 bits in length and using an 8089 algorithm can correct an erroneous burst up to 11 bits in length.

SMD Interface

High speed, reliable data transfers are a major benefit of using the SMD interface. A data transfer rate of 1.2 MB is accomplished by using separate (radial) differential data line cabling for each drive. Control signals are daisy-chained from drive to drive.

Defective Track Handling

When a track is deemed defective, the host processor reformats the track, giving it a defective track code and enters the address of the next available alternate track. When the controller accesses a track previously marked defective, the controller automatically seeks to the assigned alternate track. The alternate track seek is totally automatic and invisible to the user.

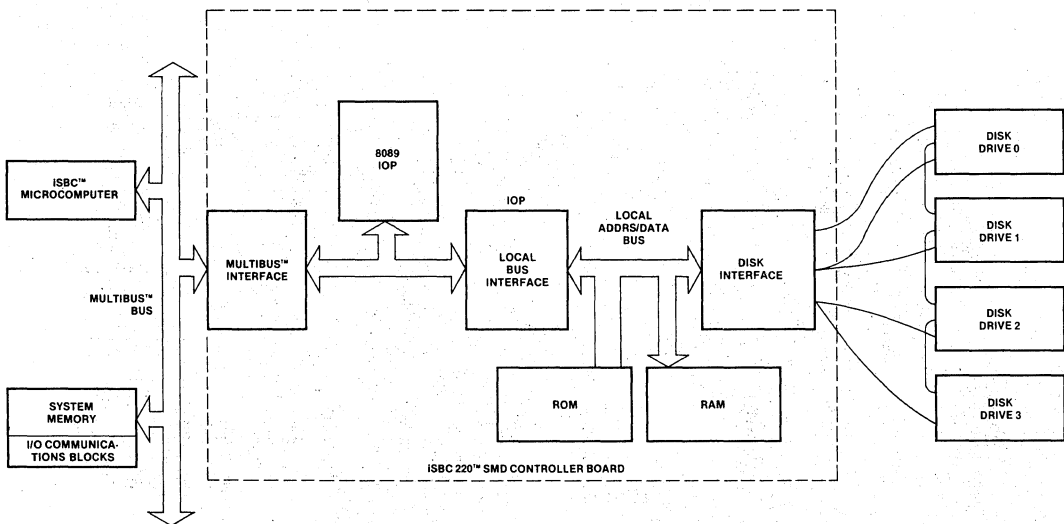

Figure 1. Simplified Block Diagram of iSBC 220™ SMD Disk Controller

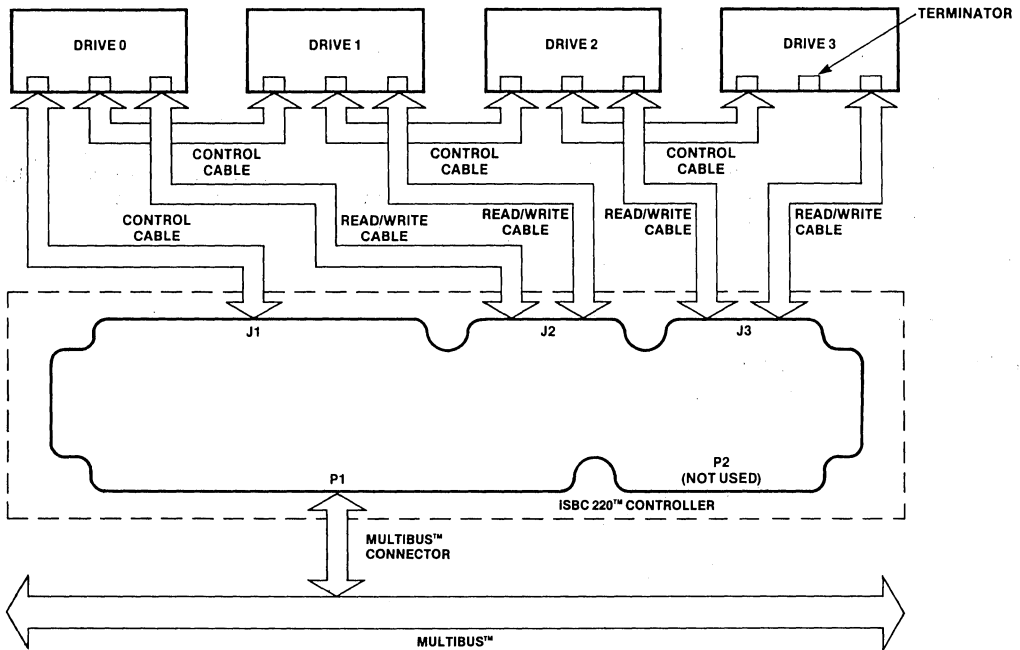

Figure 2. Typical Multiple Drive System

SPECIFICATIONS

Compatibility

CPU — Any iSBC MULTIBUS computer or system mainframe

Disk Drive — Any SMD interface-compatible disk drive

Equipment Supplied

iSBC 220 SMD Disk Controller
Reference schematic

Controller-to-drive cabling and connectors are not supplied with the controller. Cables can be fabricated with flat cable and commercially-available connectors as described in the iSBC 220 SMD Disk Controller Hardware Reference Manual.

Physical Characteristics

Width — 6.75 in. (17.15 cm)

Height — 0.5 in. (1.27 cm)

Length — 12.0 in. (30.48 cm)

Shipping Weight — 19 oz (0.54 kg)

Mounting — Occupies one slot of iSBC system chassis or cardcage/backplane

Electrical Characteristics

Power Requirements

+ 5 VDC @ 3.25A max

- 5 VDC @ 0.75A max¹

Note 1: On-board voltage regulator allows optional - 12 VDC usage from MULTIBUS.

Data Organization and Capacity

Bytes per Sector² — 128 256 521 1024

Sectors per Track² — 108 64 35 18

Note 2: Software selectable.

Table 1. Drive Characteristics (Typical)

| | |
|----------------------|---|
| Disk (spindle) Speed | 3600 rpm |
| Tracks per Surface | 823 |
| Head Positioning | Closed loop servo type, track following |
| Access Time | Track to Track 6 ms |
| | Average 30 ms |
| | Maximum 55 ms |
| Data Transfer Rate | 1.2 megabytes/second |
| Storage Capacity | 12 to 2.4 gigabytes |



Environmental Characteristics

Temperature — 0°C to 55°C (operating); -55°C to +85°C (non-operating)

Humidity — Up to 90% relative humidity without condensation (operating); all conditions without condensation or frost (non-operating)

Reference Manual

121597-001 — iSBC 220 SMD Disk Controller Hardware Reference Manual (NOT SUPPLIED)

Reference manuals may be ordered from any Intel sales representative, distributor office, or from Intel Literature Department, 3065 Bowers Avenue, Santa Clara, CA 95051.

ORDERING INFORMATION

| Part Number | Description |
|-------------|---------------------|
| SBC 220 | SMD Disk Controller |