



INTELLEC[®] DOUBLE DENSITY DISKETTE OPERATING SYSTEM HARDWARE REFERENCE MANUAL

Intel Corporation, Santa Clara, California 95051

© 1977 Intel Corporation

Intel Corporation, 3065 Bowers Avenue, Santa Clara, California 95051

Intel Corporation, Santa Clara, California 95051

Intel Corporation, Santa Clara, California 95051

Intel Corporation, Santa Clara, California 95051

Intel Corporation, Santa Clara, California 95051

Additional copies of this manual or other Intel literature may be obtained from:

Literature Department
Intel Corporation
3065 Bowers Avenue
Santa Clara, CA 95051

The information in this document is subject to change without notice.

Intel Corporation makes no warranty of any kind with regard to this material, including, but not limited to, the implied warranties of merchantability and fitness for a particular purpose. Intel Corporation assumes no responsibility for any errors that may appear in this document. Intel Corporation makes no commitment to update nor to keep current the information contained in this document.

Intel Corporation assumes no responsibility for the use of any circuitry other than circuitry embodied in an Intel product. No other circuit patent licenses are implied.

Intel software products are copyrighted by and shall remain the property of Intel Corporation. Use, duplication or disclosure is subject to restrictions stated in Intel's software license, or as defined in ASPR 7-104.9(a)(9).

No part of this document may be copied or reproduced in any form or by any means without the prior written consent of Intel Corporation.

The following are trademarks of Intel Corporation and its affiliates and may be used to identify Intel products:

BXP
CREDIT
ICE
iCS
iM
iMMX
Insite

Intel
Intel
Intelevison
Intellec
Intellink
iOSP
iPDS
iRMX

iSBC
iSBX
iSXM
Library Manager
MCS
Megachassis
Micromainframe
Micromap

Multibus
Multichannel
Multimodule
Plug-A-Bubble
PROMPT
RMX/80
System 2000
UPI

PREFACE

This reference manual is the primary source of information for the hardware within the INTELLEC Double Density Diskette Operating System. It explains how the Diskette System is installed, how it communicates with the INTELLEC Microcomputer Development System, and how it functions internally.

Refer to the ISIS-II System User's Guide (order number 98-306) for complete instructions on how to operate the Diskette System. For information on the host system, refer to the INTELLEC Microcomputer Development System Hardware Reference Manual and to the INTELLEC Microcomputer Development System Operator's Manual.

TABLE OF CONTENTS

Chapter	Title	Page	Chapter	Title	Page
1	INTRODUCTION	1-1	5	THE DISKETTE DRIVES	5-1
	1.1 SYSTEM OVERVIEW	1-1	5.1	FUNCTIONAL DESCRIPTION	5-1
	1.2 RECORDING FORMAT	1-4	5.2	PERFORMANCE CHARACTERISTICS	5-2
2	OPERATIONAL SUMMARY AND PROGRAMMING CONSIDERATIONS	2-1	5.2.1	RECORDING CHARACTERISTICS	5-2
	2.1 CHANNEL COMMANDS	2-2	5.2.2	BIT TRANSFER RATE	5-2
	2.2 DISKETTE OPERATIONS	2-5	5.2.3	DATA CAPACITY	5-2
	2.3 I/O PARAMETER BLOCK	2-8	5.2.4	LATENCY TIME	5-3
	2.4 ERROR INDICATIONS	2-11	5.2.5	POSITIONING CHARACTERISTICS	5-3
3	THE CHANNEL BOARD	3-1	5.2.6	FDD START AND STOP TIME	5-3
	3.1 FUNCTIONAL ORGANIZATION OF THE CHANNEL BOARD	3-1	5.2.7	ERROR RECOVERY	5-3
	3.2 THEORY OF OPERATION: CHANNEL BOARD	3-3	5.2.8	ENVIRONMENTAL LIMITS	5-4
	3.2.1 CHANNEL COMMAND BLOCK	3-3	5.2.9	WRITE PROTECT	5-4
	3.2.2 MICRO CONTROL UNIT (MCU) BLOCK	3-5	5.3	INTERFACE SPECIFICATIONS	5-4
	3.2.3 MICROPROGRAM MEMORY BLOCK	3-8	5.4	DISKETTE CARTRIDGE STORAGE AND HANDLING	5-9
	3.2.4 CENTRAL PROCESSING ELEMENT (CPE) BLOCK	3-12	5.5	DISKETTE CARTRIDGE WRITE PROTECT NOTCH	5-11
	3.2.5 DATA/CLOCK SHIFT REGISTER BLOCK	3-15	5.6	ADDITIONAL INFORMATION	5-11
	3.2.6 DATA FLOW CONTROL BLOCK	3-16	6	DISKETTE SYSTEM MICROPROGRAM	6-1
	3.3 SCHEMATICS/PIN LISTS: CHANNEL BOARD	3-17	6.1	INTRODUCTION	6-1
4	THE INTERFACE BOARD	4-1	6.2	MICROPROGRAM MODULE DESCRIPTION	6-1
	4.1 FUNCTIONAL ORGANIZATION OF THE INTERFACE BOARD	4-1	7	UTILIZATION	7-1
	4.2 THEORY OF OPERATION: INTERFACE BOARD	4-3	7.1	ENVIRONMENTAL EXTREMES	7-1
	4.2.1 DISK DRIVE CONTROL	4-3	7.2	MOUNTING RECOMMENDATIONS	7-1
	4.2.2 WRITE DATA GENERATOR	4-6	7.3	ELECTRICAL CONNECTIONS	7-1
	4.2.3 SERIAL DATA/CLOCK SYNCHRONIZATION	4-10	7.4	BASE ADDRESS SELECTION	7-2
	4.2.4 CYCLIC REDUNDANCY CHECK (CRC)	4-10	7.5	INTERRUPT LEVEL SELECTION	7-2
	4.2.5 BUS CONTROL	4-13	8	OPERATING CHARACTERISTICS	8-1
	4.3 SCHEMATICS/PIN LISTS: INTERFACE BOARD	4-15	8.1	AC CHARACTERISTICS	8-1
			8.2	DC CHARACTERISTICS	8-9

LIST OF ILLUSTRATIONS

Chapter	Title	Page
1	INTRODUCTION	1-1
	1-1 DISKETTE SYSTEM BLOCK DIAGRAM	1-2
	1-2 PHYSICAL DATA FORMAT	1-6
	1-3 BYTE REPRESENTATION	1-7
	1-4 DATA BYTES	1-7
	1-5 DATA BIT	1-8
	1-6 BIT CELL	1-8
	1-7 TRACK FORMAT	1-9
	1-8 INDEX ADDRESS MARK	1-10
	1-9 ID ADDRESS MARK	1-10
	1-10 DATA ADDRESS MARK	1-11
	1-11 DELETED DATA ADDRESS MARK	1-11
2	OPERATIONAL SUMMARY AND PROGRAMMING CONSIDERATIONS	2-1
	2-1 SECTOR FORMAT	2-7
	2-2 'DATA' ADDRESS MARK	2-7
	2-3 'DELETED DATA' ADDRESS MARK	2-7
	2-4 I/O PARAMETER BLOCK (IOPB) FORMAT	2-9
3	CHANNEL BOARD	3-1
	3-1 CHANNEL BOARD: FUNCTIONAL BLOCK DIAGRAM	3-2
	3-2 3001 MICROPROGRAM CONTROL UNIT: FUNCTIONAL BLOCK DIAGRAM	3-6
	3-3 3002 CENTRAL PROCESSING ELEMENT: FUNCTIONAL BLOCK DIAGRAM	3-14
	3-4 SCHEMATIC DRAWING: CHANNEL BOARD	3-21
4	INTERFACE BOARD	4-1
	4-1 INTERFACE BOARD: FUNCTIONAL BLOCK DIAGRAM	4-2
	4-2 HEAD MOVEMENT CONTROL TIMING	4-5
	4-3 READ INITIATE TIMING	4-6
	4-4 M ² FM DATA ENCODING	4-7
	4-5 PRECOMPENSATION TIMING	4-8
	4-6 WRITE DATA TIMING	4-9
	4-7 PHASE LOCKED OSCILLATOR	4-11
	4-8 READ SYNCHRONIZATION TIMING	4-12
	4-9 BUS CONTROL TIMING	4-14
	4-10 CLK1/ AND CLK2/ TIMING	4-15
	4-11 SCHEMATIC DRAWING: INTERFACE BOARD	4-22
5	DISKETTE DRIVES	5-1
	5-1 FDD/FDCC INTERFACE LINES	5-6
	5-2 FDD DRIVER/RECEIVER CIRCUITS	5-7
	5-3 WRITE DATA TIMING	5-8
	5-4 READ DATA TIMING	5-10
	5-5 FLEXIBLE DISK CARTRIDGE	5-11

LIST OF ILLUSTRATIONS (Continued)

Chapter	Title	Page
6	DISKETTE SYSTEM MICROPROGRAM	6-1
6-1	INITIALIZATION	6-2
6-2	MAINLINE	6-3
6-3	LOAD MA LOWER	6-4
6-4	LOAD MA UPPER AND START I/O	6-5
6-5	READ RESULT BYTE	6-6
6-6	IOPB LOADER/OP DECODE	6-7
6-7	I/O FINISH	6-8
6-8	SEEK	6-9
6-9	FORMAT	6-10
6-10	RECALIBRATE	6-12
6-11	VERIFY/READ	6-13
6-12	WRITE DELETED/WRITE	6-15
6-13	ADDRESS PARAMETER CHECKER	6-16
6-14	READ NEXT MEMORY WORD	6-17
6-15	WRITE DATA FIELD	6-18
6-16	WRITE CURRENT CHECK	6-19
6-17	TIME-OUT	6-20
6-18	ADDRESS MARK DETECT	6-21
6-19	HEAD STEPPER	6-22
6-20	READ DISK BYTE	6-23
6-21	PROCESS ADDRESS FIELD	6-24
6-22	WRITE ADDRESS FIELD	6-25
7	UTILIZATION	7-1
7-1	CONNECTORS ON THE CHANNEL AND INTERFACE BOARDS	7-3
8	OPERATING CHARACTERISTICS	8-1
8-1	SLAVE COMMAND TIMING — FDCC	8-2
8-2	BUS EXCHANGE TIMING	8-3
8-3	MASTER COMMAND TIMING	8-4
8-4	STEP/SETTLING TIMINGS	8-6
8-5	READ TIMING	8-7
8-6	WRITE TIMING	8-7
8-7	INDEX TIMING	8-8
8-8	WRITE FAULT RESET TIMING	8-8

LIST OF TABLES

Chapter	Title	Page
1	INTRODUCTION	
1-1	DISKETTE DRIVE PERFORMANCE SPECIFICATIONS	1-3
2	OPERATIONAL SUMMARY AND PROGRAMMING CONSIDERATIONS	
2-1	INTERRUPT CONTROL BITS	2-11
3	THE CHANNEL BOARD	
3-1	ACO INPUT SELECTION	3-7
3-2	MICROINSTRUCTION BIT ASSIGNMENTS	3-9
3-3	CONTROL PULSES AND LEVELS GENERATED BY MICROPROGRAM	3-10
3-4	I-BUS SELECTION BY MASK FIELD BITS	3-12
3-5	K-BUS INPUT SELECTION	3-13
3-6	PIN LIST: P1 BUS CONNECTOR	3-17
3-7	PIN LIST: P2 CONTROLLER CONNECTOR	3-19
4	THE INTERFACE BOARD	
4-1	PIN LIST: P1 BUS CONNECTOR	4-16
4-2	PIN LIST: P2 CONTROLLER CONNECTOR	4-18
4-3	J1 DRIVE CONNECTOR	4-19
8	OPERATING CHARACTERISTICS	
8-1	DISKETTE OPERATING SYSTEM/INTELLEC BUS AC CHARACTERISTICS	8-1
8-2	DISKETTE OPERATING SYSTEM/DRIVE INTERFACE AC CHARACTERISTICS	8-5
8-3	DISKETTE OPERATING SYSTEM DC CHARACTERISTICS (INTELLEC BUS)	8-9
8-4	DISKETTE OPERATING SYSTEM DC CHARACTERISTICS (DRIVE/DISPLAY INTERFACE)	8-12

CONFIDENTIAL

MEMORANDUM FOR THE DIRECTOR, FBI

DATE: 10/15/54

RE: [Illegible]

1. [Illegible]

2. [Illegible]

3. [Illegible]

4. [Illegible]

5. [Illegible]

6. [Illegible]

CHAPTER 1

INTRODUCTION

The INTELLEC Double Density Diskette Operating System provides a bulk storage capability for Intel's INTELLEC Microcomputer Development System. The Diskette System includes an intelligent controller and up to four diskette drives. Each drive provides 4,100,096 user-accessible data bits of storage with a data transfer rate of 500,000 bits/second. The controller has been implemented with Intel's powerful Series 3000 Bipolar Computing Elements. The controller provides an interface to the INTELLEC System bus, as well as supporting the four diskette drives. The Diskette System records all data in the Intel soft-sectored format, described in Section 1.2.

1.1 SYSTEM OVERVIEW

In addition to two or four diskette drives, their enclosure(s) (two drives per enclosure) and power supplies, the Diskette System consists of the Channel Board and the Interface Board. These two printed circuit boards reside in the INTELLEC System cabinet and constitute the diskette controller. Each of the system components is shown in Figure 1-1, and described in the following paragraph:

The Channel Board is the primary control module within the Diskette System. The Channel Board receives, decodes and responds to channel commands from a Central Processor Unit (CPU) in the INTELLEC System. The Channel Board can access INTELLEC System memory to determine the particular diskette operations to be performed and to fetch the parameters required for the successful completion of the specified operations. The Channel Board also monitors Diskette System status and error conditions, and organizes these indications into 'result type' and 'result byte' words that can be read by a CPU in the INTELLEC System.

The control functions of the Channel and Interface Boards are provided by an 8-bit microprogrammed processor, implemented with Intel's Series 3000 Bipolar Computing Elements. The 8-bit controller includes four 3002 Central Processing Elements (2-bit slice per CPE), a 3001 Microprogram Control Unit and 512 x 32 bits of 3604 programmable-read-only-memory (PROM) which stores the microprogram. The processing and control capabilities of the Diskette System are achieved by execution of the microprogram.

The Interface Board provides the diskette controller with a means of communicating with the diskette drives, as well as with the INTELLEC System bus. Under control of the microprogram executed from the Channel Board, the Interface Board generates those signals which cause the read/write head on the selected drive to be loaded (i.e., to come in contact with the diskette platter), then cause the head to move to the proper track. The Interface Board accepts the data being read off the diskette, interprets certain synchronizing bit patterns, checks the validity of the data using a cyclic redundancy check (CRC) polynomial, and passes the data to the Channel Board.

During write operations, the Interface Board outputs the data and clock bits to the selected drive at the proper times. It also generates CRC characters which are appended to the data; this allows the data to be verified when it is subsequently read.

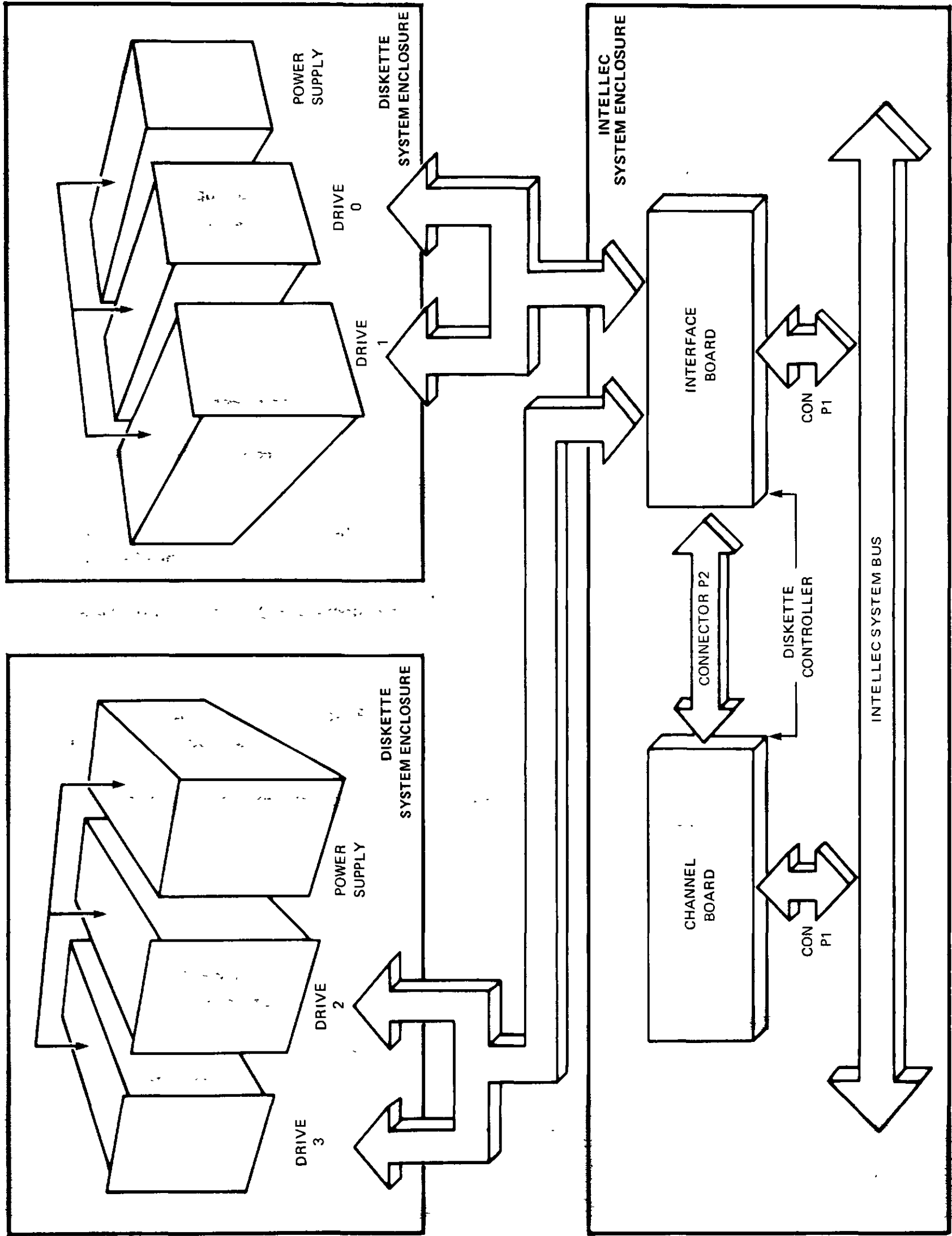

Figure 1-1 DISKETTE SYSTEM BLOCK DIAGRAM

When the diskette controller requires access to INTELLEC System memory, the Interface Board requests and maintains master control of the system bus, and generates the appropriate memory command.

When a CPU in the INTELLEC System issues a channel command to the Diskette System, the Interface Board acknowledges the command as required by INTELLEC System bus protocol.

Each diskette drive consists of read/write and control electronics (on a single printed circuit board), drive mechanism, read/write head, track positioning mechanism and the removable diskette platter. These components interact to perform the following functions:

- Interpret and generate control signals.
- Move read/write head to selected track.
- Read and write data.

Table 1-1 lists the performance characteristics for each diskette drive.

**TABLE 1-1
DISKETTE DRIVE PERFORMANCE SPECIFICATIONS**

Capacity (formatted)	Per Disk --	512,512 bytes
	Per Track --	6,656 bytes
Data Transfer Rate:		500 kilobits/second
Access Time:	Track to Track --	10 ms
	Settling Time --	10 ms
Average Access Time:		260 ms
Rotational Speed:		360 RPM
Average Latency:		83 ms
Recording Mode:	(M ² FM) Modified-Modified Frequency Modulation	

The remaining chapters of the manual deal with each of the system elements in detail. Chapter 2 describes the range of operations that can be performed by the Diskette System, and also provides specific information on how to program the system to execute each of the possible operations. Chapters 3 and 4 provide detailed information on the theory of operation for the Channel Board and the Interface Board, respectively. The final section in each of these chapters provides a complete schematic drawing of the board as well as a detailed pin list. The reader should continually refer to these schematic drawings in the course of reading the theory of operation sections.

NOTE: To avoid any confusion when referring to the schematics for the Channel and Interface Boards, or when reading the corresponding circuit descriptions, the following notation, concerning the active level of a signal, will apply:

Whenever a signal is active-low, its mnemonic is followed by a slash; for example MRDC/ means that the level on that line will be low when the memory read command is true (active). If the signal is subsequently inverted, thus making it active-high, the slash is omitted; for example, MRDC means that the level on that line will be high when the memory command is true.

Chapter 5 lists the manufacturer's information on the diskette drives. Chapter 6 provides the major state flow charts for the microprogram which is executed by the Series 3000 Bipolar Microcomputer Set (on the Channel Board), and which essentially controls operation of the Diskette System. Chapter 7 provides basic information on the installation and use of the Diskette System. Finally, Chapter 8 summarizes the AC and DC operating characteristics for the Diskette System.

Before proceeding to Chapter 2, however, we first provide a comprehensive review of the Intel soft-sectored recording format which is used by the Diskette Operating System.

1.2 RECORDING FORMAT

This section summarizes the specifications for the soft-sectored recording format used by the Diskette Operating System.

Physical Data Format:

The physical data format is the format that the diskette controller circuitry must interact with. The elements of the physical data format are the hard index hole, index mark, sector address marks, sector headers, and data sectors. The index mark and sector address marks are recorded with unique clock patterns requiring the controller circuitry to accumulate the unique clock patterns for index and sector address mark identification. Figure 1-2 illustrates the general physical data format.

A 'byte', when referring to serial data (being written to or read from the diskette drive), is defined as eight (8) consecutive bit cells. The most significant bit cell is defined as bit cell 0 and the least significant bit cell is defined as bit cell 7. When reference is made to a specific data bit (i.e., data bit 3), it is with respect to the corresponding bit cell (bit cell 3).

During a write operation bit cell 0 of each byte is transferred to the drive first with bit cell 7 being transferred last. Correspondingly, the most significant byte of data is transferred to the diskette first and the least significant byte is transferred last.

When data is being read back from the drive, bit cell 0 of each byte will be transferred first with bit cell 7 last. As with reading, the most significant byte will be transferred first from the drive to the user.

Figure 1-3 illustrates the relationship of the bits within a byte and Figure 1-4 illustrates the relationship of the bytes for read and write data.

Data is recorded on the diskette using modified modified (M^2) frequency modulation as the recording mode. Data written on and read back from the disc takes the form shown in Figure 1-5. Clock bits are written only if there is no data bit in the bit cell and there was no data bit or clock bit written in the previous bit cell. By definition, a Bit Cell is the period (2 us) consisting of a clock bit time (1 us) and a data bit time (1 us). Figure 1-6 illustrates a Bit Cell.

Track Format:

Each track recorded on a diskette consists of 52 fixed length records along with necessary gaps for record updating. Figure 1-7 illustrates the format of one complete track.

Each field on a track is separated from adjacent fields by a number of bytes containing no data. These areas are referred to as gaps and are provided to allow the updating of one field without affecting adjacent fields. As can be seen from Figure 1-7, there are four different types of gaps on each track:

Gap 1 – Post-Index Gap

This gap is defined as the 28 bytes between Index Address Mark and the ID Address Mark for Sector one (excluding the address mark bytes). This gap is always 28 bytes in length and is not affected by any updating process.

Gap 2 – ID Gap

The 28 bytes between the ID Field and the Data Field are defined as Gap 2 (ID Gap). This gap does not vary in size.

Gap 3 – Data Gap

The 28 bytes between the Data field and the next ID field are defined as Gap 3 (Data Gap). The Data Gap may vary slightly in length after the adjacent Data field has been updated, due to differences in disk rotational speed between formatting and updating of individual data fields.

Gap 4 – Pre-Index Gap

The 338 bytes between the last Data field on a track and the Index Address Mark are defined as Gap 4 (Pre-Index Gap). Initially, this gap is nominally 338 bytes in length; however, due to write frequency tolerances and diskette speed tolerances this gap may vary slightly in length. Also, after the data field of record 52 has been updated this gap may again change slightly in length.

Address Marks:

Address Marks are unique bit patterns one byte in length which are used to identify the beginning of ID and Data fields and to synchronize the deserializing circuitry with the first byte of each field. Address Mark bytes are unique from all other data bytes in that each Address Mark contains an extra clock bit in bit cell 2. There are four different types of Address Marks used. Each of these is used to identify different types of fields:

Index Address Mark

The Index Address Mark is located at the beginning of each track and is a fixed number of bytes in front of the first record. The bit configuration for the Index Address Mark is shown in Figure 1-8.

ID Address Mark

The ID Address Mark byte is located at the beginning of each ID field on the diskette. The bit configuration for this Address Mark is shown in Figure 1-9.

Data Address Mark

The Data Address Mark byte is located at the beginning of each non-deleted Data Field on the diskette. The bit configuration for this Address Mark is shown in Figure 1-10.

Deleted Data Address Mark

The Deleted Data Address Mark byte is located at the beginning of each deleted Data field on the diskette. The bit configuration for this Address Mark is shown in Figure 1-11.

CRC Bytes:

Each field written on the diskette is appended with two Cyclic Redundancy Check (CRC) bytes. These two CRC bytes are generated from a cyclic permutation of the data bits starting with bit zero of the address mark and ending with bit seven of the last byte within a field (excluding the CRC bytes). This cyclic permutation is the remainder from the division of the data bits in the field (represented as an algebraic polynomial) by a generator polynomial $G(X)$. For all fields recorded on a diskette, this generator polynomial is:

$$G(X) = X^{16} + X^{12} + X^5 + 1$$

When a field is read back from a diskette, the data bits (from bit zero of the address mark to bit seven of the second CRC byte) are divided by the same generator polynomial $G(X)$ and a non-zero remainder indicates an error within the data read back from the drive while a remainder of zero indicates the data has been read back correctly from the diskette or an undetectable error has been read back.

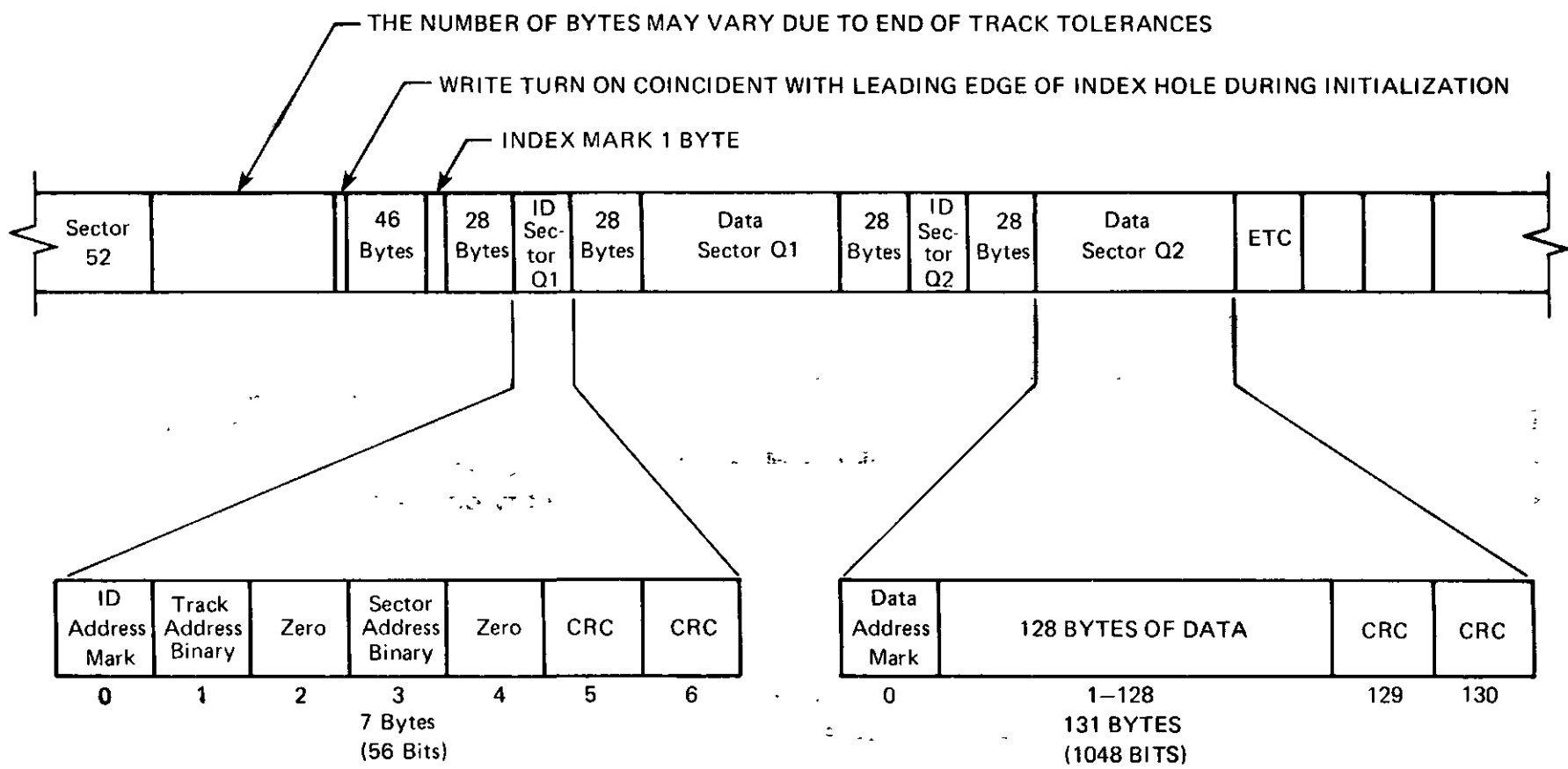

Figure 1-2 PHYSICAL DATA FORMAT

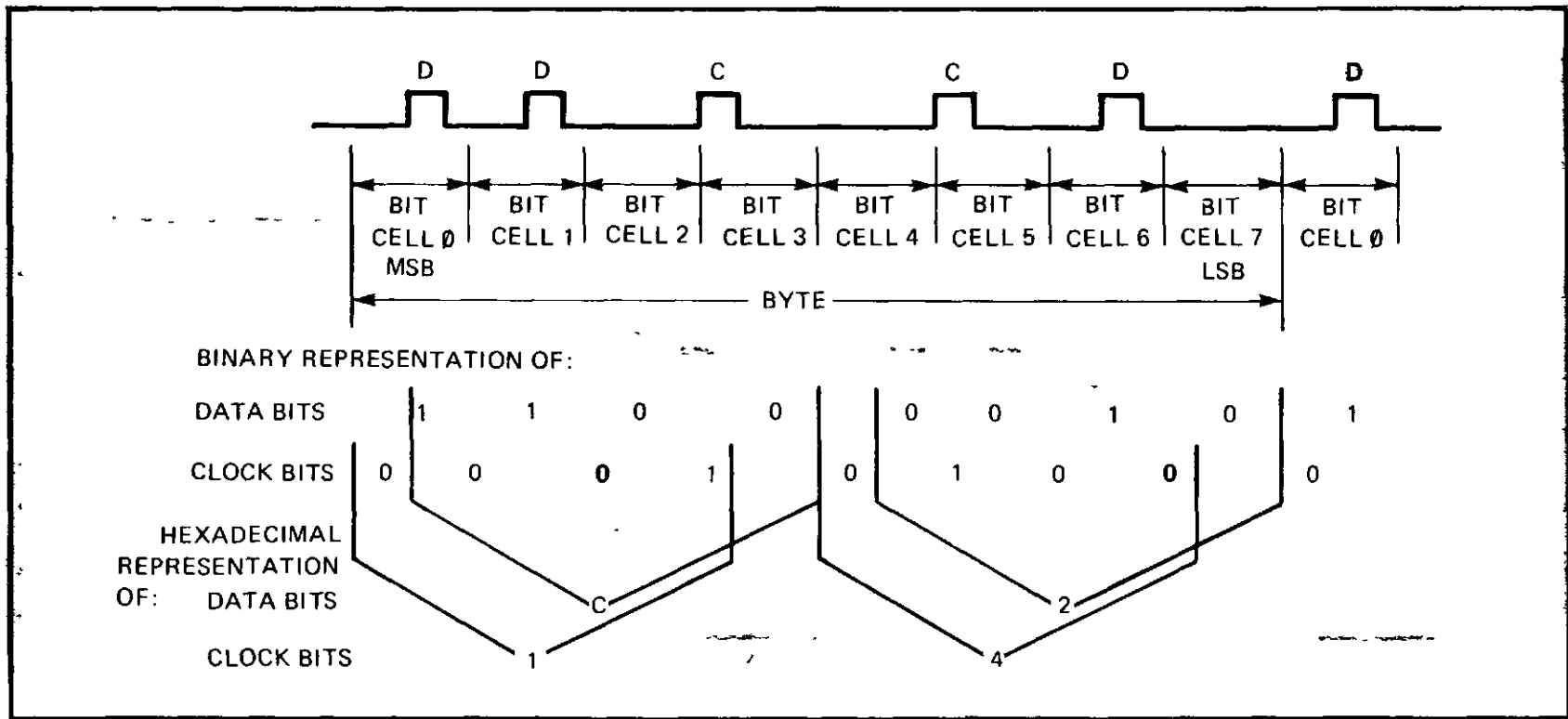

Figure 1-3 BYTE REPRESENTATION

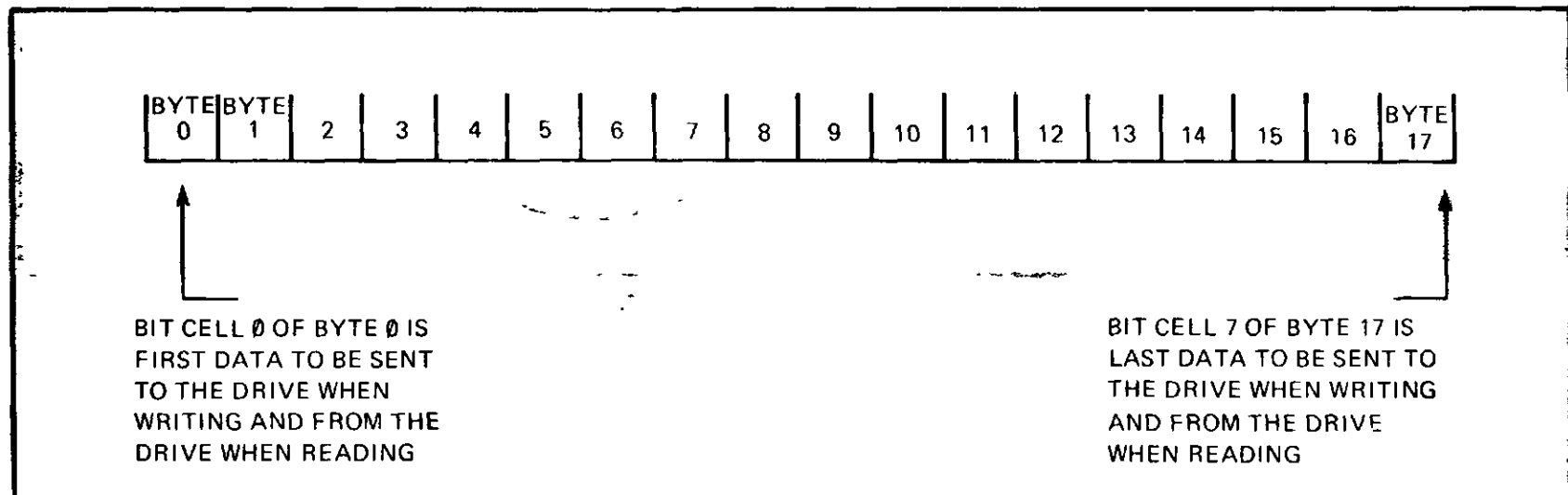

Figure 1-4 DATA BYTES

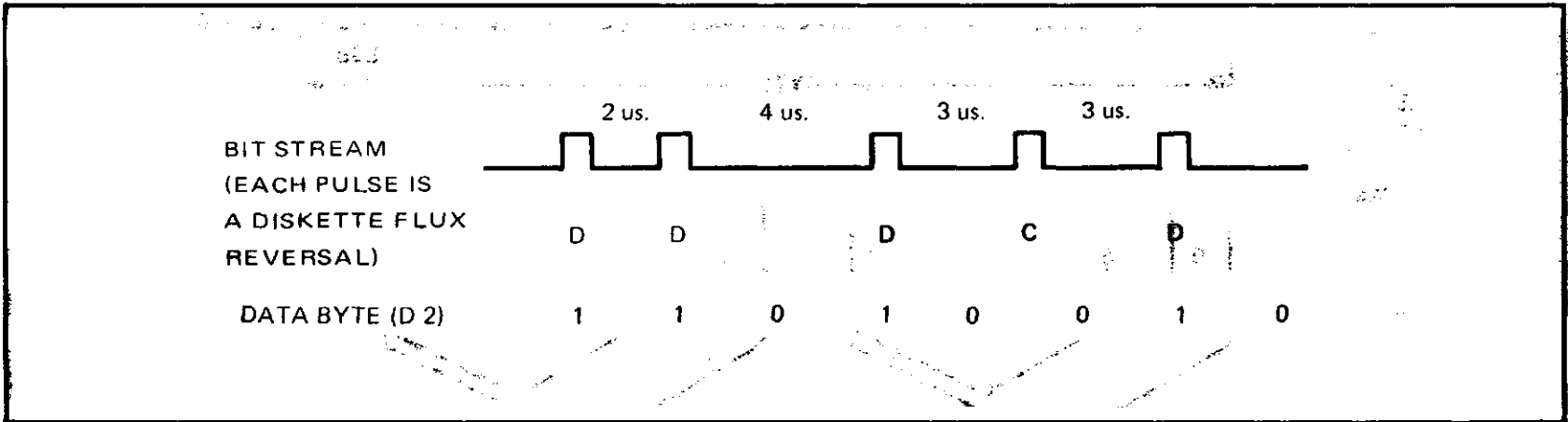

Figure 1-5 DATA BIT

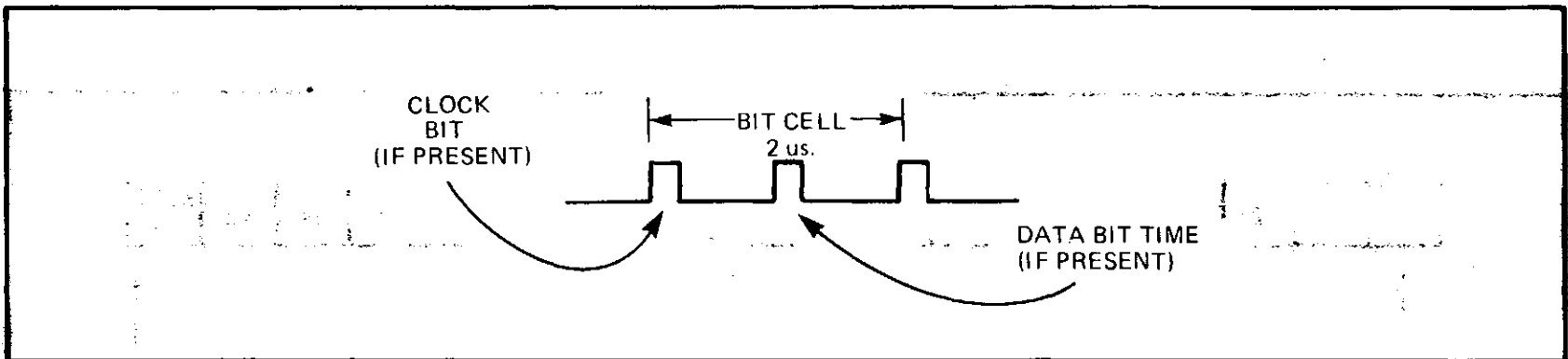

Figure 1-6 BIT CELL

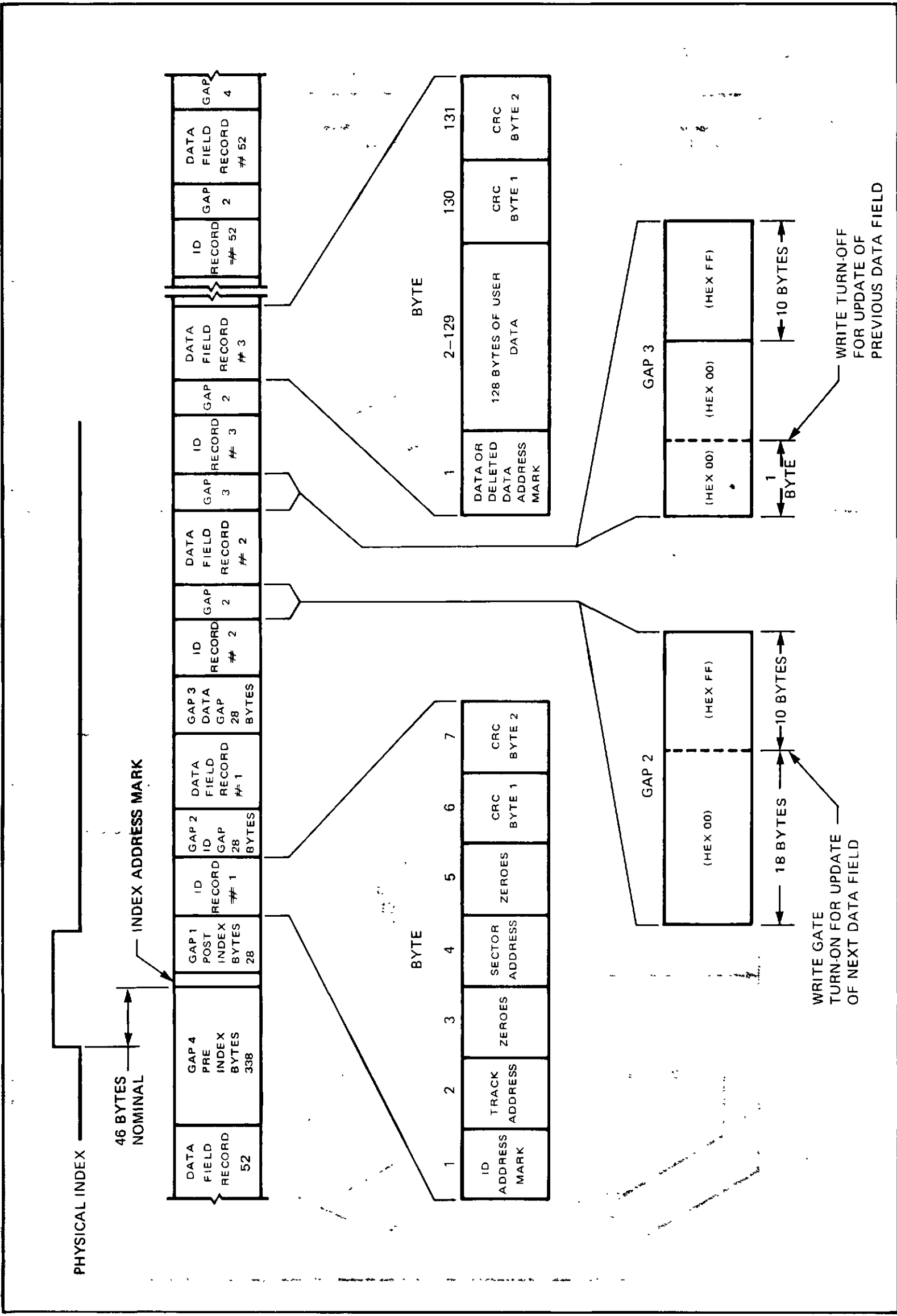

Figure 1-7 TRACK FORMAT

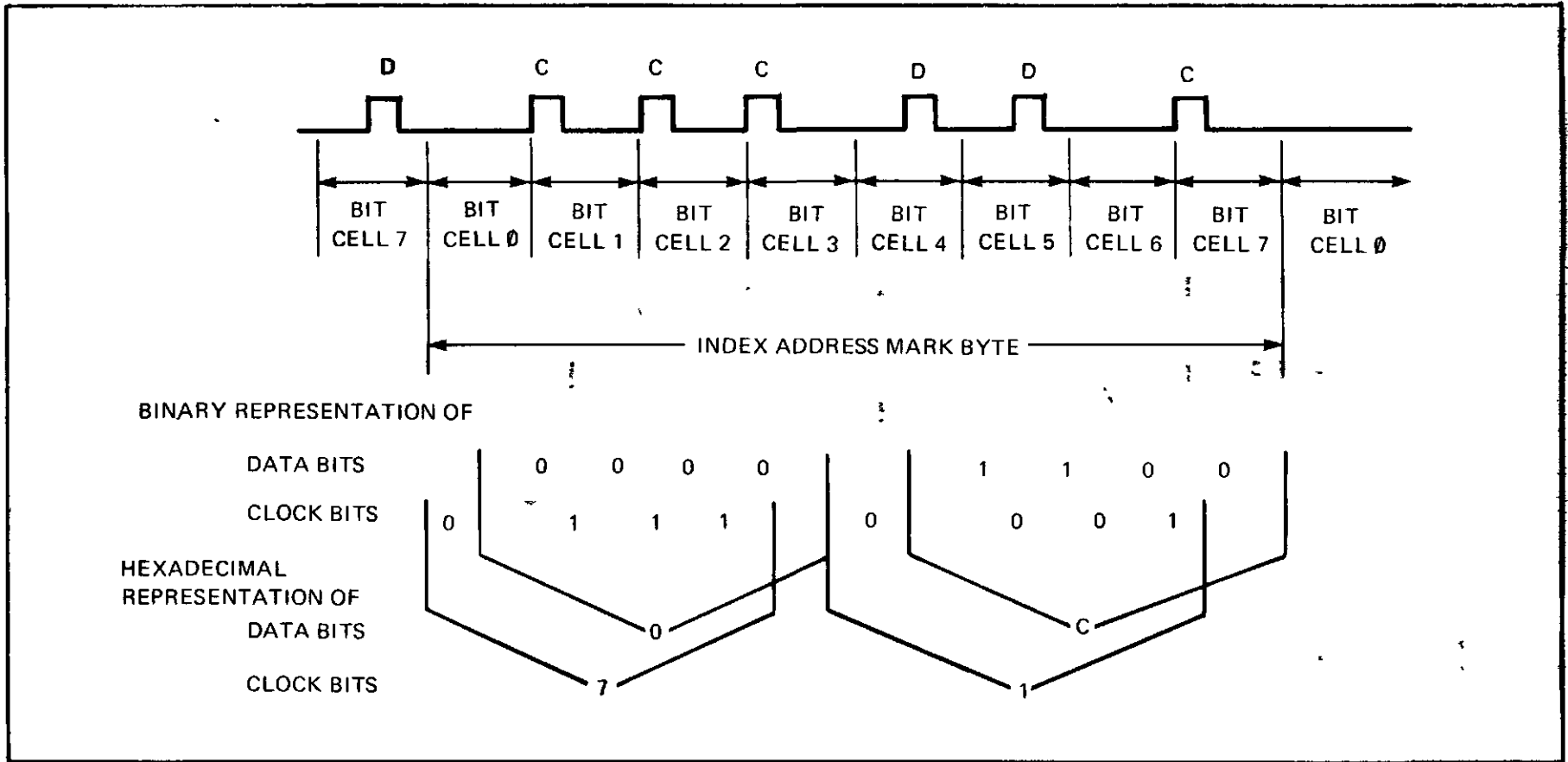

Figure 1-8 INDEX ADDRESS MARK

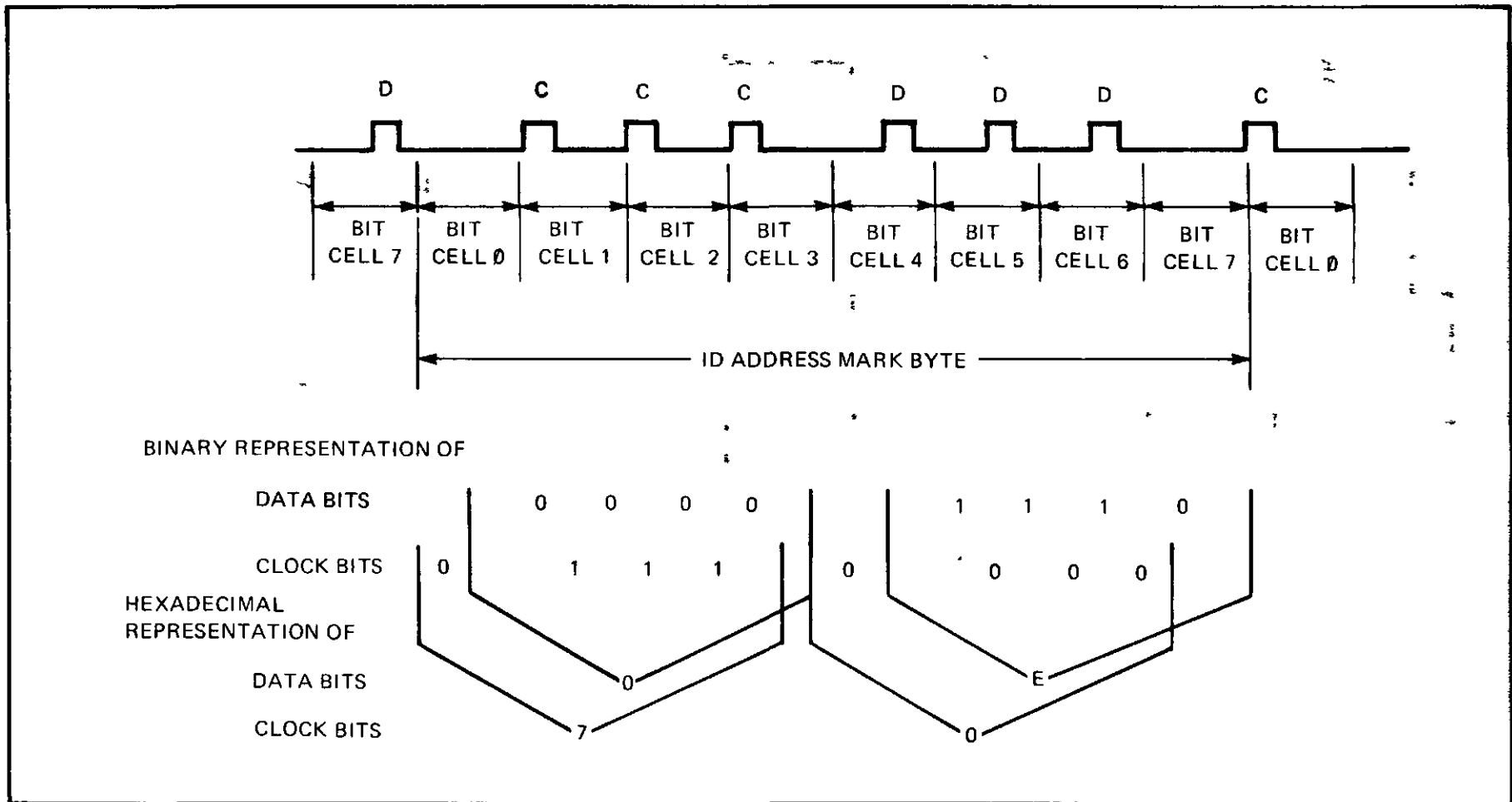

Figure 1-9 ID ADDRESS MARK

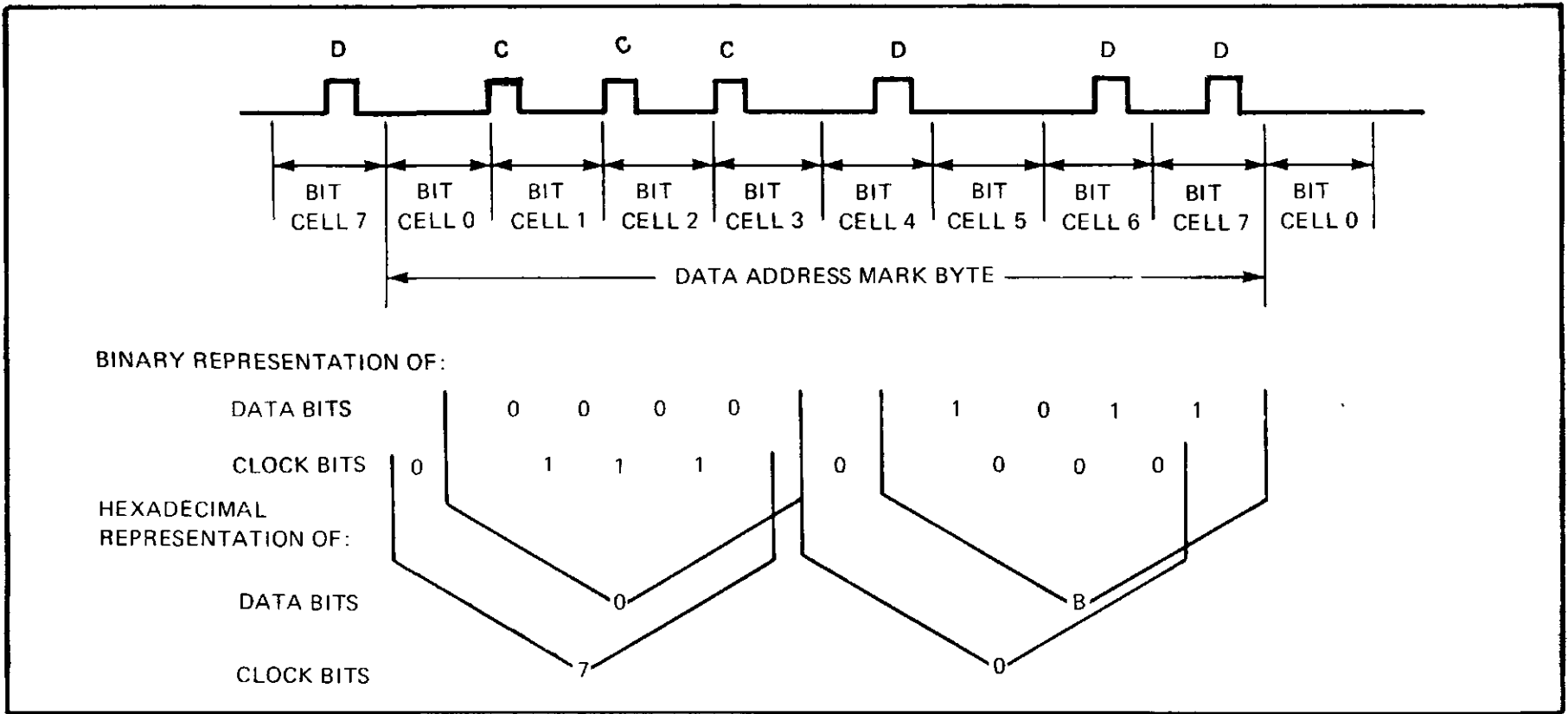

Figure 1-10 DATA ADDRESS MARK

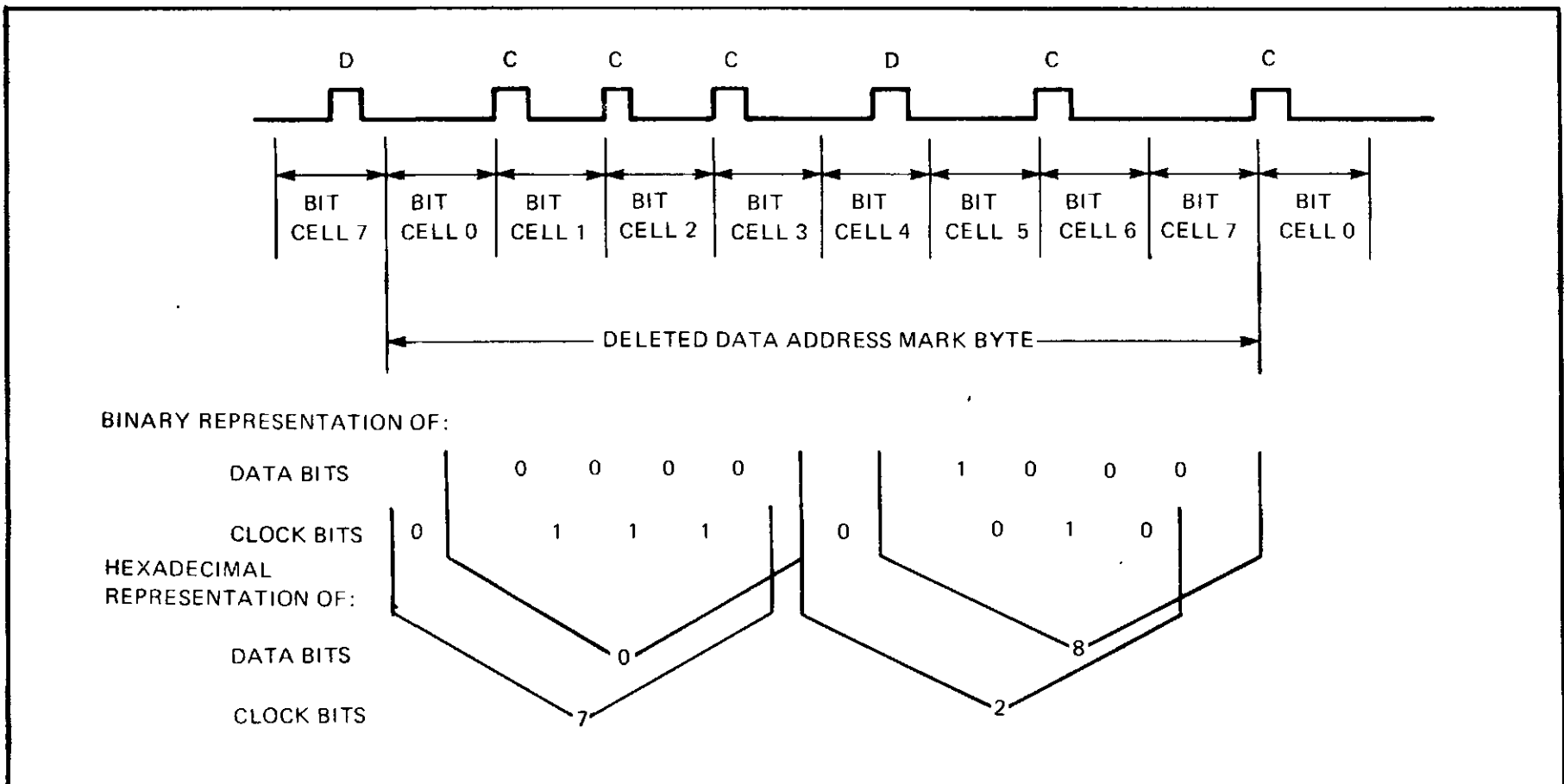

Figure 1-11 DELETED DATA ADDRESS MARK

Figure 1-11 DELETED DATA ADDRESS MARK

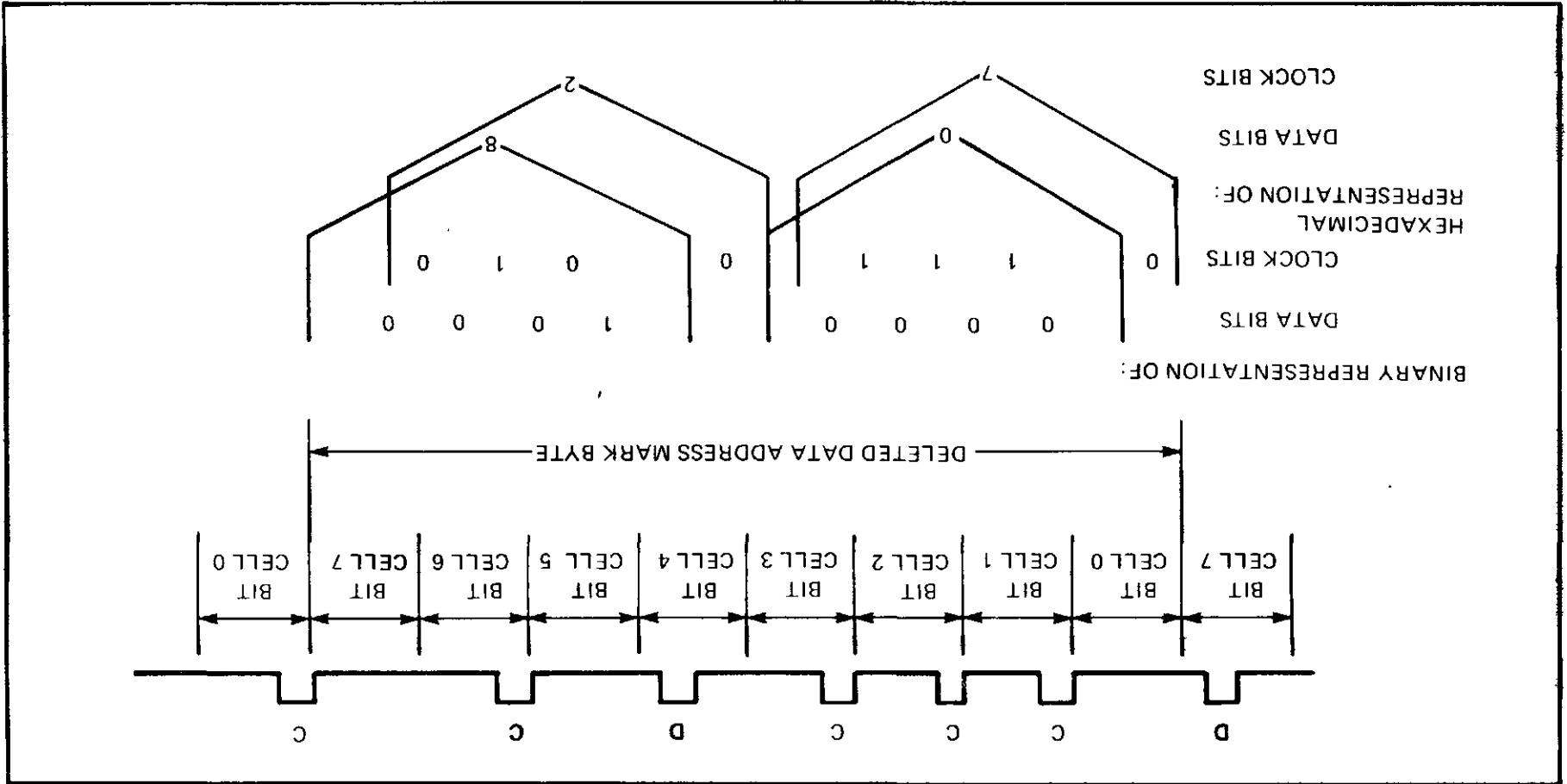
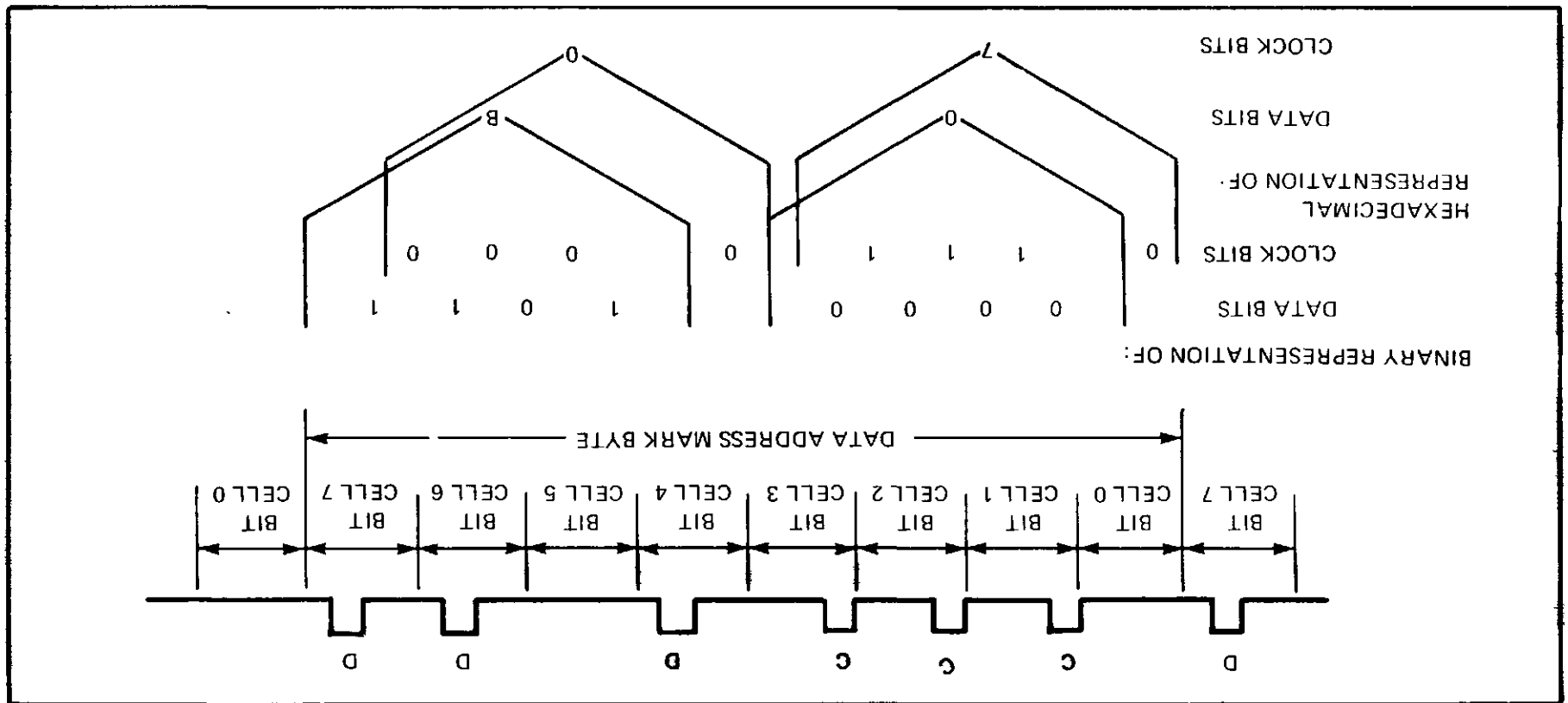

Figure 1-10 DATA ADDRESS MARK



CHAPTER 2

OPERATIONAL SUMMARY AND PROGRAMMING CONSIDERATIONS

All diskette operations are initiated by a Central Processor Unit (CPU) within the INTELLEC System. Once initiated, however, the Diskette Channel completes the specified operation without further intervention on the part of the CPU. From the CPU's point of view, there are only three general steps required to complete any diskette operation:

- The CPU must prepare and store in system memory an I/O Parameter Block (IOPB) for each operation to be performed. An IOPB (seven bytes) specifies a particular diskette operation and provides all of the parameters required for execution of that operation.
- The CPU must then pass the memory address of the IOPB to the Diskette Channel.
- The CPU must process the result information from the Diskette Channel upon completion of the operation(s).

The preparation of the IOPB by the CPU, in itself, requires no interaction with the Diskette Channel. The passing of the memory address for the IOPB and the result processing, however, do require interaction. Six channel commands have been defined to allow the CPU to perform these interactive steps. Three of the channel commands are the result of the CPU executing an output instruction to a dedicated I/O port address, while the other three commands are the result of input instructions to dedicated ports. The six channel commands are:

- (1) Write memory address lower (output)
- (2) Write memory address upper and start the diskette operation (output)
- (3) Reset the channel (output)
- (4) Read subsystem status (input)
- (5) Read result type (input)
- (6) Read result byte (input)

The CPU outputs the memory address of the IOPB by executing channel commands 1 and 2. Upon execution of channel command 2, the Diskette Channel will request master control of the INTELLEC System bus, fetch the diskette instruction and associated parameters from the IOPB, and proceed to perform the specified diskette operation. The diskette instruction byte in the IOPB can specify any one of seven diskette operations:

- (1) Recalibrate (seek track 00)
- (2) Seek
- (3) Format a track
- (4) Write data (with data address marks)
- (5) Write data (with deleted address marks)
- (6) Read data
- (7) Verify CRC

The Diskette Channel can interrupt the CPU when the operation is completed or when the diskette ready status changes. The host system software can implement its CPU interrupt mechanism via this direct interrupt feature or it can 'poll' the Diskette Channel by executing channel command 4 (read subsystem status). When the CPU determines that the operation sequence has been completed (either by receiving an interrupt request or by reading

FORMAT TRACK

This operation initializes the track specified in byte 4 of the IOPB, by writing all address marks, gaps, address fields and data fields, as shown in Figure 2-1. The various address marks and fields are defined in Section 1.2.

The method of assigning logical sector addresses, which are written into the sector address fields, is specified by bit 6 of the first IOPB byte (the channel word). If this bit is equal to logical 0 the sequence of logical sector addresses will match the physical sequence on the diskette (i.e., sector address '01' is written into the first physical sector after the index mark, sector address '02' is written into the second physical sector, and so on). In addition, the data byte stored in the memory location specified by the 16-bit buffer address contained in bytes 6 and 7 of the IOPB will be written into the 128-byte locations of each sector's data field. No other data bytes need to be stored in this buffer.

If, on the other hand, the sequence of logical addresses being assigned to the sectors is 'random' (that is, do not match the physical sequence of sectors), bit 6 of the channel word will be equal to logical 1, and 104 bytes (52 pairs) of data will be stored in memory beginning at the 16-bit buffer address contained in bytes 6 and 7 of the IOPB. Each of the 52 pairs of data bytes will specify the logical sector address to be written into the sector address field of the corresponding physical sector, and the data character which will be written (128 times) into the data field portion of that sector. For example, if the first four bytes of the buffer are:

Byte	Contents (hex)
1	01
2	FF
3	0E
4	00
.	.
.	.

Then, sector address '01' will be written into the sector address field of the first physical sector after the index mark, and 'FF₁₆' (all ones) will be written into each of the 128 byte locations in the data field portion of this sector. The sector address '0E₁₆' (14₁₀) will be written into the sector address field of the second physical sector (i.e., the sector which is physically next to the first sector), and '00₁₆' (all zeros) will be written into each of the 128 byte locations in the data field portion of this sector. And so on, until a logical sector address has been written into the sector address field of each of the 52 physical sectors on the track, and a data byte is written into each of the 128 byte locations in the data field portion of each of the 52 sectors.

The firmware implementation of the format command is such that in order to format track n (n≠0), track n-1 must already be formatted (i.e., already have readable address information written into it). Track 0 can always be formatted even if no valid address information is written on the disk.

During formatting, a 'data mark' (i.e., a character which has a clock pattern equal to 70₁₆ and a data pattern equal to 0B₁₆; see Figure 2-2) is written into the 'data/deleted data address mark' character position of each sector (i.e., the character position immediately preceding the 128 byte data field.)

If, when the format track operation is initiated, the head is not already positioned over the track specified in byte 4 of the IOPB, the format track instruction will cause the head to move (seek) to the proper track before the actual formatting begins.

WRITE DATA

This operation transfers N x 128 bytes of contiguous data from memory to the diskette. N represents the number of sectors to be written. N is specified by the contents of byte 3 of the IOPB. The 16-bit buffer address stored in bytes 6 and 7 of the IOPB specifies the memory location containing the first data byte to be transferred. The contents of bytes 4 and 5 of the IOPB (track and sector addresses, respectively) specify the logical address of the first sector to be written into.

executed sequentially ('read result type' first), and should be executed only in response to an interrupt request from the Diskette Channel; execution at other times could produce erroneous result data.

The use and format of each of the six channel commands is described below:

WRITE MEMORY ADDRESS LOWER (OUTPUT)

This channel command outputs the low order byte of the 16-bit memory address that points to byte 1 ('channel word') of the IOPB.

System address bus: BASE + 1

System data bus: Eight least significant bits of the 16-bit memory address that points to the first IOPB.

WRITE MEMORY ADDRESS UPPER AND START THE DISKETTE OPERATION (OUTPUT)

This channel command outputs the high order byte of the 16-bit memory address that points to byte 1 of the IOPB. This command also causes the Diskette Channel to begin executing the diskette operation specified in byte 2 (instruction byte) of the addressed IOPB.

System address bus: BASE + 2

System data bus: Eight most significant bits of the 16-bit memory address

RESET DISKETTE SYSTEM (OUTPUT)

This output channel command causes all control logic in the Diskette Channel to be reset in an initialized state. If this command is issued while a 'write data' diskette operation is in progress, the data in the sector currently being written will be garbled. This command is intended to clear a 'hang up' in the Diskette Channel.

System address bus: BASE + 7

System data bus: Not used.

READ SUBSYSTEM STATUS (INPUT)

This input channel command causes the Diskette Channel to return.

bit 0 — ready status of drive 0
bit 1 — ready status of drive 1
bit 2 — state of the channel's interrupt flip-flop
bit 3 — controller presence indicator
bit 4 — double density controller presence indicator
bit 5 — ready status of drive 2
bit 6 — ready status of drive 3

Each 128 byte data field will be preceded by a 'data' address mark (see Figure 2-2) that is used for synchronization. Two bytes (16 bits) of CRC check bits will be generated and written after each data field; the CRC bytes are generated from the address mark, as well as the 128 data bytes.

A multi-sector operation (i.e., $N \geq 2$) may begin at any sector, but must not go beyond the last logical sector on a track (sector 52).

If the head is not already positioned over the track specified in byte 4 of the IOPB, the write data instruction will cause the head to move (seek) to the proper track before the actual writing begins.

WRITE 'DELETED' DATA

This operation is identical to the WRITE DATA operation, described above, except that each 128 byte data field is preceded by a 'deleted data' address mark, shown in Figure 2-3.

READ DATA

This operation transfers N sectors of data (128 bytes per sector) from diskette to memory. N is specified by the contents of byte 3 of the IOPB. The contents of bytes 4 and 5 of the IOPB (track and sector addresses, respectively) specify the logical address of the first sector to be read. The 16-bit buffer address stored in bytes 6 and 7 of the IOPB specifies the memory location into which the first data byte will be written.

Two bytes of CRC check bits will be generated as each sector is being read. When the 'data' address marks and all 128 data bytes of a sector have been read, the generated CRC bits are compared with the 16 CRC bits previously written. If there is a mismatch, a CRC error is indicated (see Section 2.4).

A multi-sector operation (i.e., $N \geq 2$) may begin at any sector, but must not go beyond the last logical sector on a track (sector 52).

If the head is not already positioned over the track specified in byte 4 of the IOPB, the read data instruction will cause the head to move (seek) to the proper track before the actual data reading begins.

VERIFY CRC

This operation is identical to the READ DATA operation, described above, except that no data is transferred to memory.

2.3 I/O PARAMETER BLOCK

The CPU in the INTELLEC System initiates a diskette operation by outputting a 16-bit address that points to the beginning (the channel word) of the I/O Parameter Block (IOPB) in system memory. The Diskette Channel then accesses the IOPB. An IOPB specifies one of the diskette operations (see Section 2.2) and provides all of the parameters required for the completion of that operation. An IOPB consists of seven bytes, as shown in Figure 2-4.

Byte 1. Channel Word

This byte contains channel control information to be used by the Diskette System. Bit assignments in this byte are as follows:

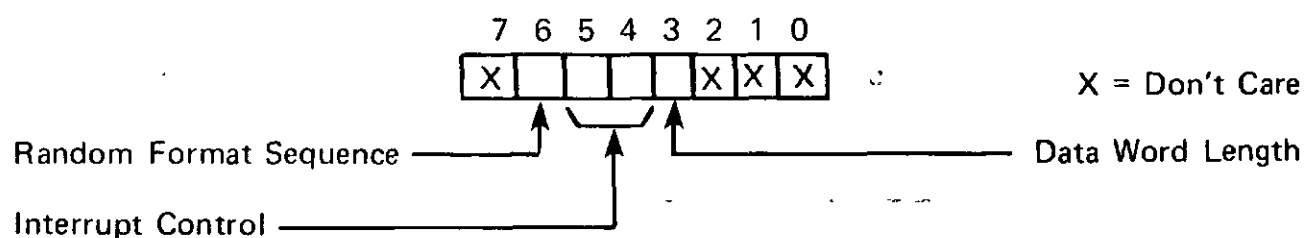

If the type code = 10, the controller has detected a change in the ready status of a drive and the contents of the result byte will indicate the current ready status of the diskette drives:

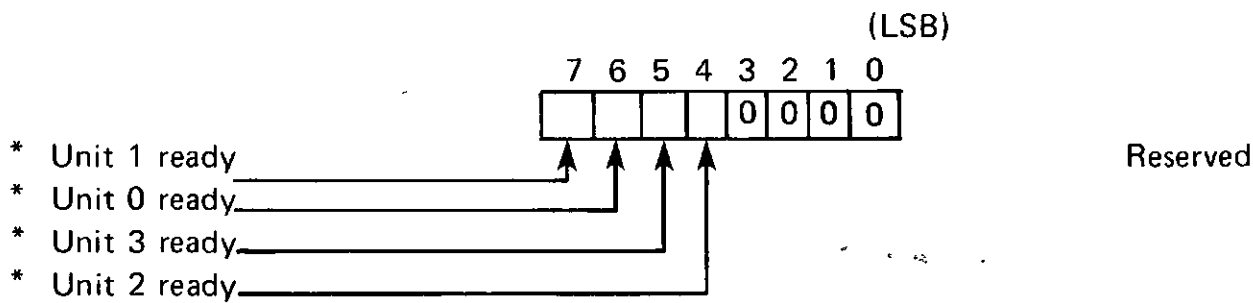

* NOTE: A logical 1 means that the drive is currently ready; a logical 0 means the drive is not ready. It is the responsibility of the host system software to maintain appropriate tables to track these status changes. There is one instance in which a drive can appear 'not ready' to the host system, when in fact it is ready. For example, assume that while drive 0 is selected, drive 1 just goes not ready then returns to the ready state (perhaps the diskette platter was changed). When the drive 0 operation is completed, the diskette controller will return two consecutive status change interrupts, the first showing drive 1 not ready, the second showing drive 1 ready. The first interrupt, indicating drive 1 to be not ready, is returned even though the drive is now actually ready because it is important that the operator know that the ready status of the drive changed while the other drive was selected. For instance, this would protect against inadvertently accessing an 'unknown' disk, if the drive went not ready then ready again because someone changed disk platters.

2.2 DISKETTE OPERATIONS

The Diskette System is capable of performing seven different operations: recalibrate, seek, format track, write data (with data marks), write data (with deleted data marks), read data, and verify CRC. To initiate any diskette operation, the CPU will output both bytes of the 16-bit memory address that points to the first byte of an I/O Parameter Block (IOPB). The second byte in the IOPB specifies one of the seven diskette operations (see Section 2.3 for IOPB format). After the Diskette System receives the upper byte of the 16-bit memory address, it accesses the IOPB to determine the operation to be performed and to acquire the various parameters that are necessary for execution of the diskette instruction. The Diskette System will perform the specified operation, then set its interrupt flip-flop.

NOTE: The Diskette Channel automatically unloads the read/write head after a fixed length of time following a diskette operation. This feature is meant to reduce head wear. The feature is implemented by counting index pulses after a 'read result byte' channel command is executed. When the specified count is achieved, the head is unloaded, and the count is re-initialized. At present, the count is set for 6; that is, the head will remain loaded for at least five complete revolutions following each diskette operation or group of linked diskette operations.

The seven diskette operations are defined in the following paragraphs:

RECALIBRATE

This operation causes the head of the selected diskette unit to be moved over track 00. The diskette drive's track 0 sensor is sampled to determine successful completion of this operation. This is often the first instruction executed after a diskette is loaded, or when a seek error occurs (see Section 2.4).

SEEK

This operation causes the head of the selected diskette unit to be moved over the track specified in byte 4 of the IOPB. The Diskette Channel will verify the head position by reading the track address from the diskette platter before completing the operation. If at the completion of the head movement, the head is not over the expected track, a 'seek error' will be indicated (see Section 2.4).

These indications allow the operating system to monitor the operation of the Diskette Channel.

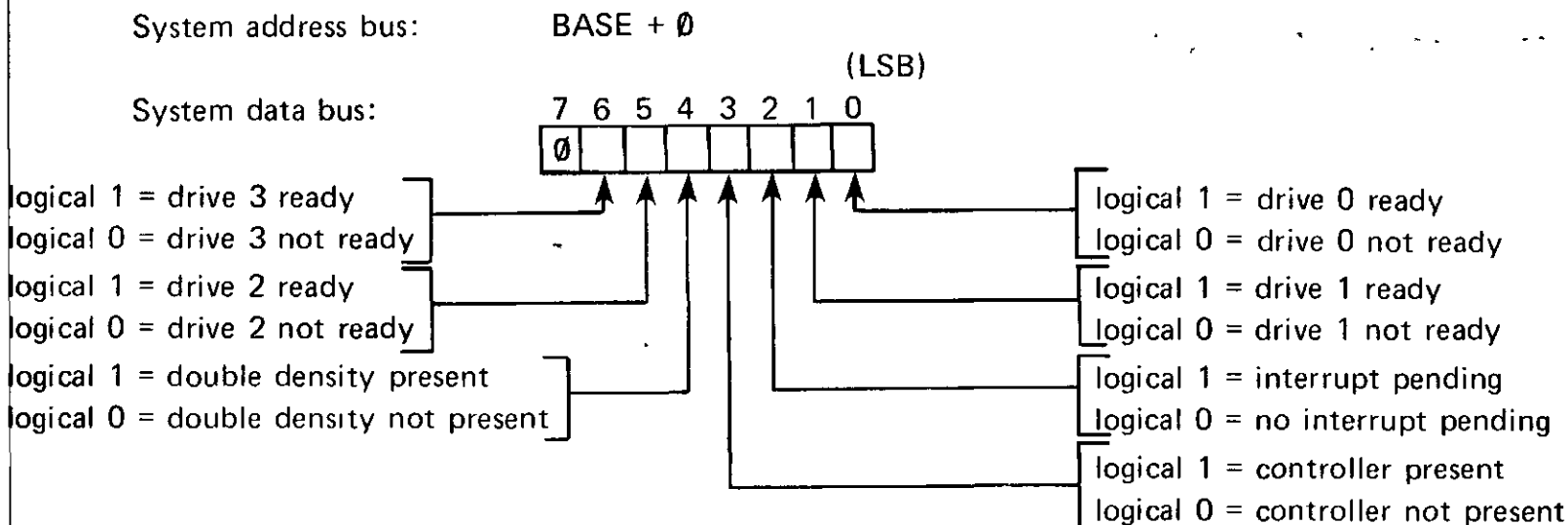

READ RESULT TYPE (INPUT)

This input channel command causes the Diskette Channel to return eight bits of information to the CPU. The two least significant bits specify one of four different types of result byte (see next paragraph) associated with diskette operations.

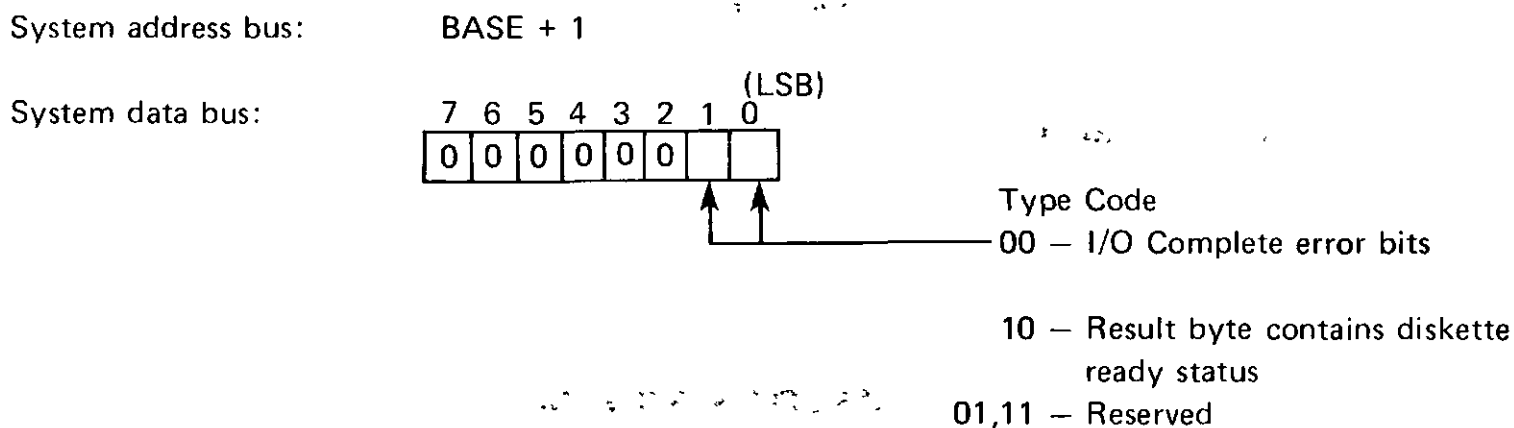

READ RESULT BYTE (INPUT)

This input channel command causes the Diskette Channel to return eight bits of information to the CPU. The interpretation of these bits is dependent upon the type code returned in the result type word (see previous paragraph). The 'read result byte' channel command should only be executed after a 'read result type' command has been executed.

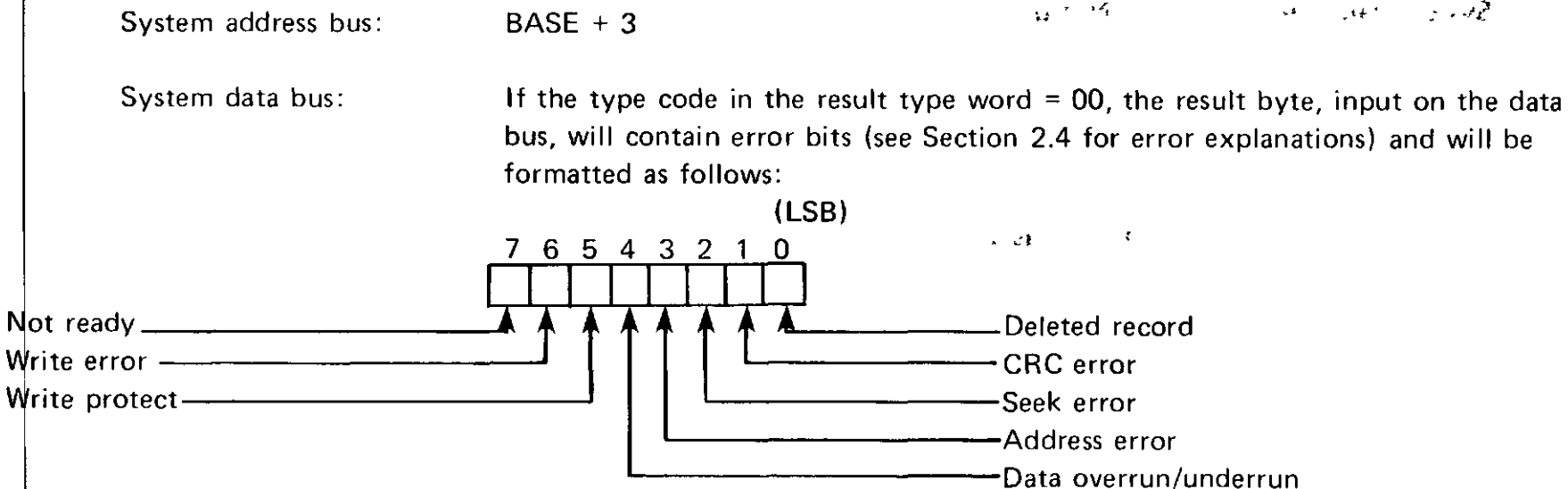

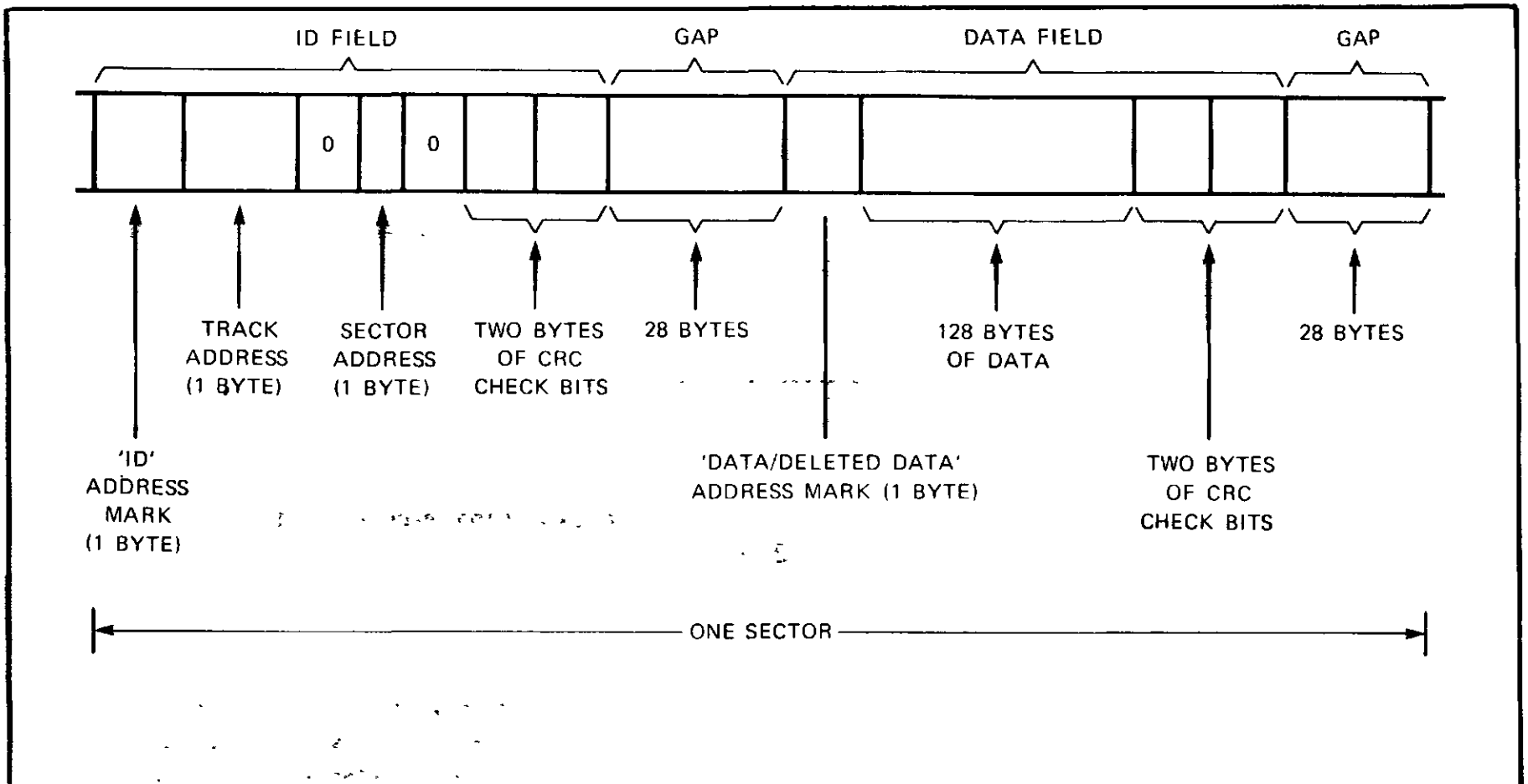

Figure 2-1 SECTOR FORMAT

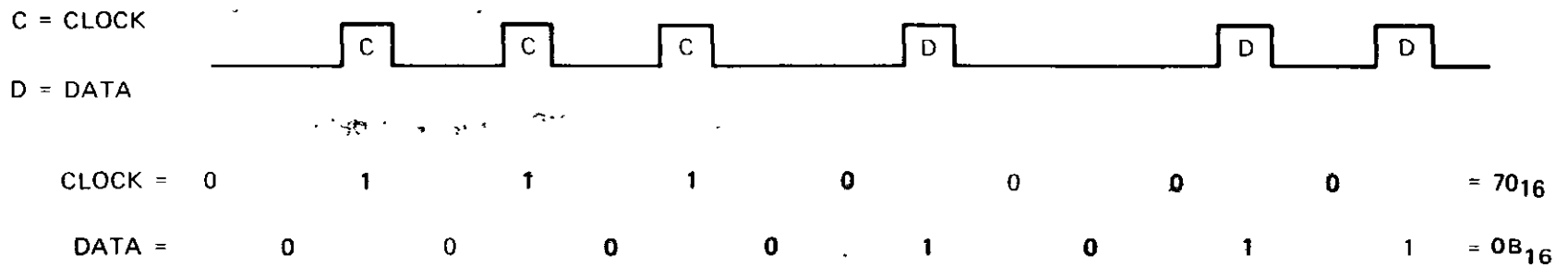

Figure 2-2 'DATA' ADDRESS MARK

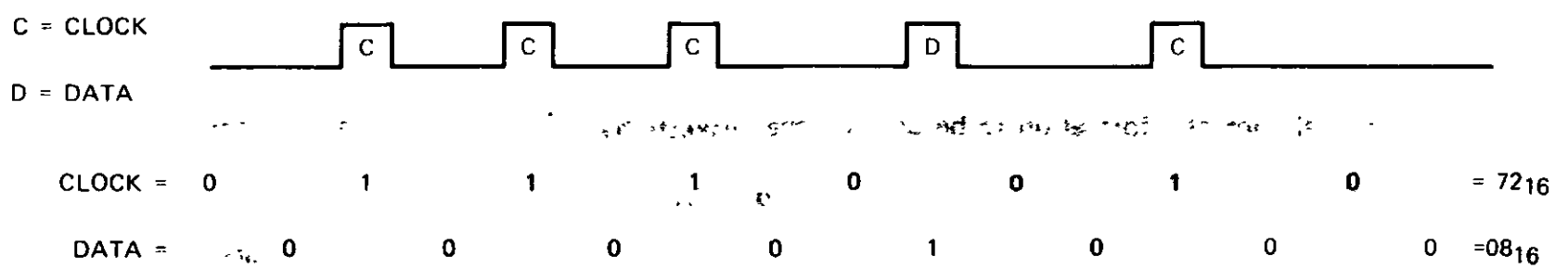

Figure 2-3 'DELETED DATA' ADDRESS MARK

the interrupt status), the CPU should execute channel commands 5 and 6 (read result type and read result byte) to determine whether the diskette operations were successfully completed, and if not which type of error occurred.

Thus, in summary, we see that certain channel commands are executed by the CPU to point the Diskette Channel to an IOPB in system memory, and initiate the operation sequence. The Diskette Channel, then, accesses the IOPB to perform the diskette operation specified by the instruction byte of the IOPB. The Diskette Channel will, if enabled by the IOPB, generate an I/O complete interrupt request upon completion of each diskette operation or detection of an error. The CPU, then, executes other channel commands to determine the result of the diskette operation.

In the preceding paragraphs, we have mentioned the channel commands, diskette operations and the IOPB without defining them explicitly. That is because up until now, our primary intention has been to identify clearly the function of each in the overall operation of the Diskette Channel. In the subsequent sections of this chapter, however, we will provide detailed information on the use and format of the channel commands (Section 2.1), the diskette operations (Section 2.2) and the IOPB (Section 2.3). Section 2.4 will define each of the error conditions that can be indicated when the 'read result byte' channel command is executed by the CPU.

2.1 CHANNEL COMMANDS

There are six channel commands to which the Diskette Channel will respond. Three of the channel commands are issued when a CPU in the INTELLEC System executes output (I/O write) instructions with the appropriate eight-bit I/O addresses. The other three commands are issued when the CPU executes input (I/O read) instructions with the appropriate I/O addresses.

When the CPU executes one of the output channel commands, it activates the I/O write (IOWC/) line and duplicates the appropriate 8-bit I/O address on address lines ADR0/ – ADR7/ and ADR8/ – ADRF/ of the INTELLEC System bus. Depending on the particular channel command, the CPU may also place relevant data on data lines DAT0/ – DAT7/ of the INTELLEC System bus. The CPU maintains the data lines until the Diskette Channel returns the transfer acknowledge (XACK/) signal.

When the CPU executes one of the input channel commands, it activates the I/O read (IORC/) line and duplicates the appropriate I/O address on both halves of the INTELLEC System bus. The CPU expects the Diskette Channel to activate the transfer knowledge (XACK/) line when it has placed the requested data on data lines DAT0/ – DAT7/.

The Diskette Channel differentiates between the different channel commands by interrogating the I/O read (IORC/) and I/O write (IOWC/) lines and the three least significant address lines (ADR0/ – ADR2/). The five most significant I/O address lines (ADR3/ – ADR7/) define the switch-selectable BASE address for the Diskette Channel.

If the Diskette Channel is not busy, it will respond to an output channel command within 3 microseconds. If it is busy, the 'write MA lower' and 'write MA upper' commands are ignored; no acknowledge is returned. (Note: Because no acknowledge is returned in this case, it could be possible to 'hang up' the host system if the system does not include a Fail Safe time-out provision, as is provided on the Front Panel Control Module in the INTELLEC System). The 'reset' command, however, is acknowledged even if the Diskette Channel is busy. 'Reset' is executed immediately (if issued during a data write operation, garbled data will be written).

The Diskette System responds to 'read subsystem status' and 'read result type' input channel commands within 1 microsecond. The information returned in response to a 'read subsystem status' command is always valid. The eight bits of data returned in response to a 'read result type' command, however, are only valid if the Diskette Channel had previously issued an interrupt request to the CPU. The Diskette Channel will, if not busy, respond to a 'read result byte' input command within 3 microseconds. If the Diskette Channel is busy, however, it ignores the 'read result byte' command (i.e., no acknowledge is returned). The 'read result type' and 'read result byte' commands must be

The 'random format sequence' bit (6) specifies the method of assigning logical sector addresses when formatting a track. If this bit is reset (logical 0), sector addresses are assigned in sequential order. If this bit is set (logical 1), sector addresses are assigned in random order according to the pattern listed in the 52 byte memory buffer, which begins at the location addressed by the contents of IOPB bytes 6 and 7. (Refer to the description of the FORMAT TRACK operation in Section 2.2.)

The 'interrupt control' bits (4 and 5) enable or disable Diskette Channel interrupts according to the scheme shown in Table 2-1.

The 'data word length' bit (3) must be reset (logical 0) when the Diskette Channel is being used with 8-bit systems, or set (logical 1) when being used with 16-bit systems. This bit must be logical 0 when being used with the INTELLEC System (an 8-bit system).

BYTE	IOPB FORMAT
*1	Channel Word
2	Diskette Instruction
3	Number of Records
4	Track Address
5	Sector Address
6	Buffer Address (Lower)
7	Buffer Address (Upper)
* The 16-bit address output to the Diskette System by the two 'Write MA' channel Commands points to the first byte of an IOPB.	

Figure 2-4 I/O PARAMETER BLOCK (IOPB) FORMAT

Table 2-1 INTERRUPT CONTROL BITS

BIT:	5	4	FUNCTION
	0	0	I/O complete interrupt request to be issued (a) upon completion of diskette operation, (b) upon detection of an error in any operation.
	0	1	All I/O complete interrupts are disabled.
	1	1	Illegal code
	1	0	
NOTE:	The interrupt control bits do not affect interrupt requests which are issued as the result of a change in diskette ready status.		

Byte 2. Diskette Instruction

This byte specifies the diskette operation to be performed and identifies the diskette unit to be used:

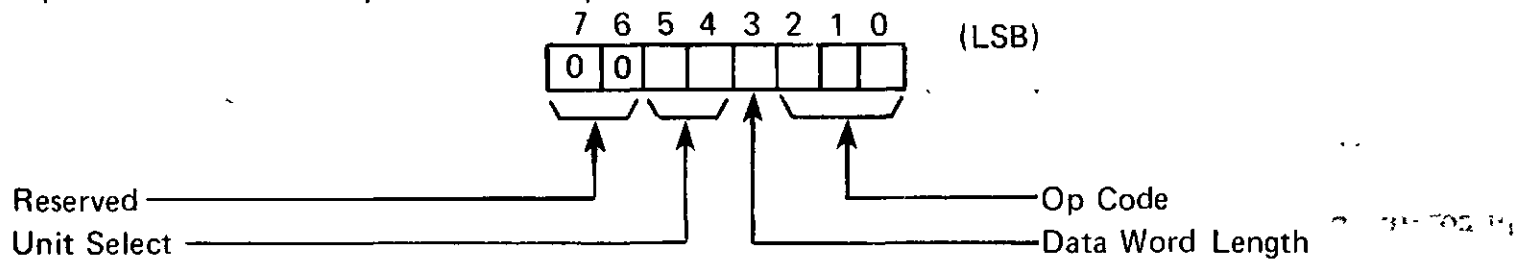

The 'unit select' bits (4 – 5) specify the drive address as follows:

00 = drive 0
 01 = drive 1
 10 = drive 2
 11 = drive 3

The 'data word length' must contain the same value as the corresponding bit in the channel word (byte 1).

The 'op code' bits (0-2) specify one of the seven diskette operations (refer to Section 2.2):

BIT:	3	2	1	OPERATION
0	0	0	0	No operation
0	0	0	1	Seek
0	1	0	0	Format Track
0	1	1	1	Recalibrate
1	0	0	0	Read data
1	0	1	1	Verify CRC
1	1	0	0	Write data
1	1	1	1	Write 'Deleted' Data

Byte 3. Number of Records

This binary number specifies the number of sectors to be transferred. Multi-sector operations are allowed, but they must not go beyond the last sector on a track (sector 52); that is, an address error (see Section 2.4) will be indicated if $(\text{starting sector address}) + (\text{number of records}) > 52_{10}$. Therefore, the maximum block transfer is 52 sectors (from sector 1 to sector 52).

Byte 4. Track Address

This binary number identifies the track. Acceptable values are 0 to $4C_{16}$ (76_{10}), inclusive.

Byte 5. Sector Address

Bits 5 through 0 of this byte contain a binary number which specifies the first sector to be accessed during transfer operations. Acceptable values are 1 to 34_{16} (52_{10}), inclusive. Bits 6 and 7 are not used.

Byte 6. Buffer Address (Lower)

This byte contains the eight least significant bits of the 16-bit buffer memory address.

Byte 7. Buffer Address (Upper)

This byte contains the eight most significant bits of the 16-bit buffer memory address. Bytes 6 and 7 together contain the 16-bit address of the first word of the buffer in system memory. During read data operations, the data from the

diskette is transferred to the buffer. During write operations, data from the buffer is written to diskette. During format track operations, the address assignment pattern and/or the data field 'format characters' are stored in the buffer.

2.4 ERROR INDICATIONS

If the CPU executes a 'read result byte' channel command (in response to a 'read result type' channel command which returned a code of 00), the Diskette Channel will return the following result word on the system data bus:

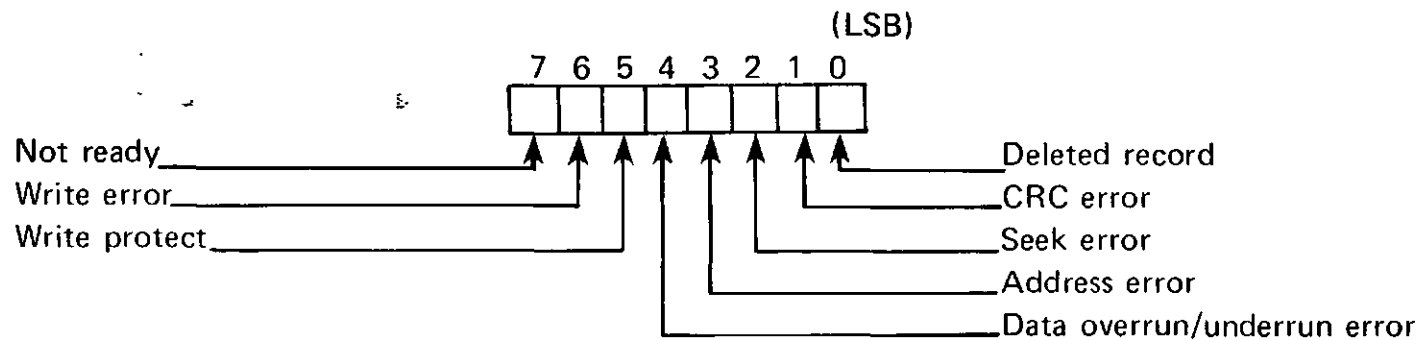

The bits are defined as follows:

NOT READY. This bit (7) indicates that the selected unit was not ready or that the selected unit changed to a not ready state during an operation.

WRITE ERROR. This bit (6) indicates that, during a write operation, a condition existed which precluded data integrity. This error is detected by the drive and monitored by the Diskette Channel controller. An example of a condition that could cause this error is an attempt to write through an unloaded head.

WRITE PROTECT. This bit (5) indicates that the selected drive contains a diskette platter which is in the 'read only' mode. This condition is checked on format track, write data (with data address marks) and write data (with deleted data address marks) operations.

DATA OVERRUN/UNDERRUN ERROR. This bit (4) indicates that the Diskette System controller was not able to service a byte transfer request from the drive before the next request occurred. The data byte is 'lost'.

ADDRESS ERROR. This bit (3) indicates that the disk address received from the CPU is invalid; that is:

- track address $> 76_{10}$,
- sector address = 00,
- sector address $> 52_{10}$, or
- sector address + number of records $> 52_{10}$

SEEK ERROR. This bit (2) indicates that, at the completion of a head movement sequence, the head is not positioned over the expected track. This bit indicates the Diskette System controller and/or drive are malfunctioning, and a recalibrate diskette operation (see Section 2.2) should be performed. Because all of the diskette operations may implicitly cause the head to move, a seek error can occur during any diskette operation.

CRC ERROR. This bit (1) indicates that the two CRC characters generated during a read data or verify CRC operation were not the same as the two CRC characters appended to the data field (see Section 1.2) when it was written on diskette.

DELETED RECORD. This bit (0) indicates that a sector addressed during a read data or verify CRC operation was preceded by a deleted data address mark.

Three other error conditions are indicated when more than one error bit is true:

ID CRC ERROR. If the address error (3) and CRC error (1) bits are true, it indicates that the CRC characters generated

during the reading of an ID field (see Section 1.2) were not the same as the CRC characters appended to the field when it was written by a format track operation.

NO ADDRESS MARK. If the address error (3), seek error (2) and CRC error (1) bits are true, it indicates that no address mark (see Section 1.2) was encountered for a full revolution of the diskette. This usually indicates that the track has not been formatted.

DATA MARK ERROR. If the address error (3), seek error (2), CRC error (1), and deleted record (0) bits are true, it indicates that the data field of a particular sector was not preceded by either a data mark or a deleted data mark.

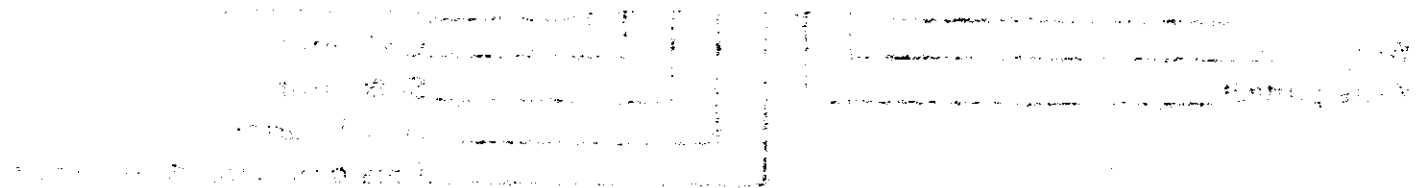

...

...

...

...

...

...

...

...

...

...

CHAPTER 3

CHANNEL BOARD

The Channel Board is the primary control module within the Diskette System. The Channel Board receives, decodes and responds to channel commands from a Central Processor Unit (CPU) in the INTELLEC System. The Channel Board can access INTELLEC System memory to determine the particular diskette operations to be performed and to fetch the parameters required for the successful completion of the specified operations. The Channel Board also monitors subsystem status and error conditions, and organizes these indications into 'result type' and 'result byte' words that can be read by a CPU in the INTELLEC System.

The control functions of the Channel and Interface Boards are provided by an 8-bit microprogrammed processor, implemented with Intel's Series 3000 Bipolar Microcomputer Set. The 8-bit controller includes four 3002 Central Processing Elements (2-bit slice per CPE), a 3001 Microprogram Control Unit and 512 x 32 bits of 3604 programmable-read-only-memory (PROM) which stores the microprogram. The processing and control capabilities of the diskette controller are achieved by execution of the microprogram.

The Channel Board resides within the INTELLEC System cabinet. The Channel Board, together with the Interface Board, constitute the Diskette Channel.

3.1 FUNCTIONAL ORGANIZATION OF THE CHANNEL BOARD

For description purposes, the circuitry on the Channel Board can be divided into six functional blocks (see Figure 3-1):

- Channel command block
- Micro control unit (MCU) block
- Microprogram memory block
- Central processing element (CPE) block
- Data/clock shift register (SR) block
- Data flow control block

The CHANNEL COMMAND BLOCK is responsible for recognizing and decoding channel commands being executed by a CPU in the INTELLEC System. When the channel command block recognizes the switch-selectable BASE address of the Diskette System on the INTELLEC System address bus, it decodes the three least significant address bits (ADR0/ – ADR2) to determine which of the six channel commands is being executed (see Section 2.1). The three address bits are also latched and made available to the MCU block, which is ultimately responsible for controlling the diskette controller's response to a channel command. The channel command block also includes the interrupt latch which stores the fact that an interrupt request has been issued to the CPU by the microprogram.

The MICRO CONTROL UNIT (MCU) BLOCK accepts and decodes the three address bits from the channel command block (ADR0/ – ADR2/) specifying a channel command or the three least significant data outputs from the CPE block (D0 – D2) specifying one of the seven diskette operations. The two groups of 3 bits select one of the ten routines which implement the channel commands and I/O operations. Having determined the microprogram routine to be executed, the MCU block then generates and outputs the appropriate nine-bit memory address from the microprogram memory. The MCU continuously examines the two flag control lines and the seven address control lines (AC0 – AC6) from the microprogram memory block to determine the address of the next microinstruction to be fetched and executed.

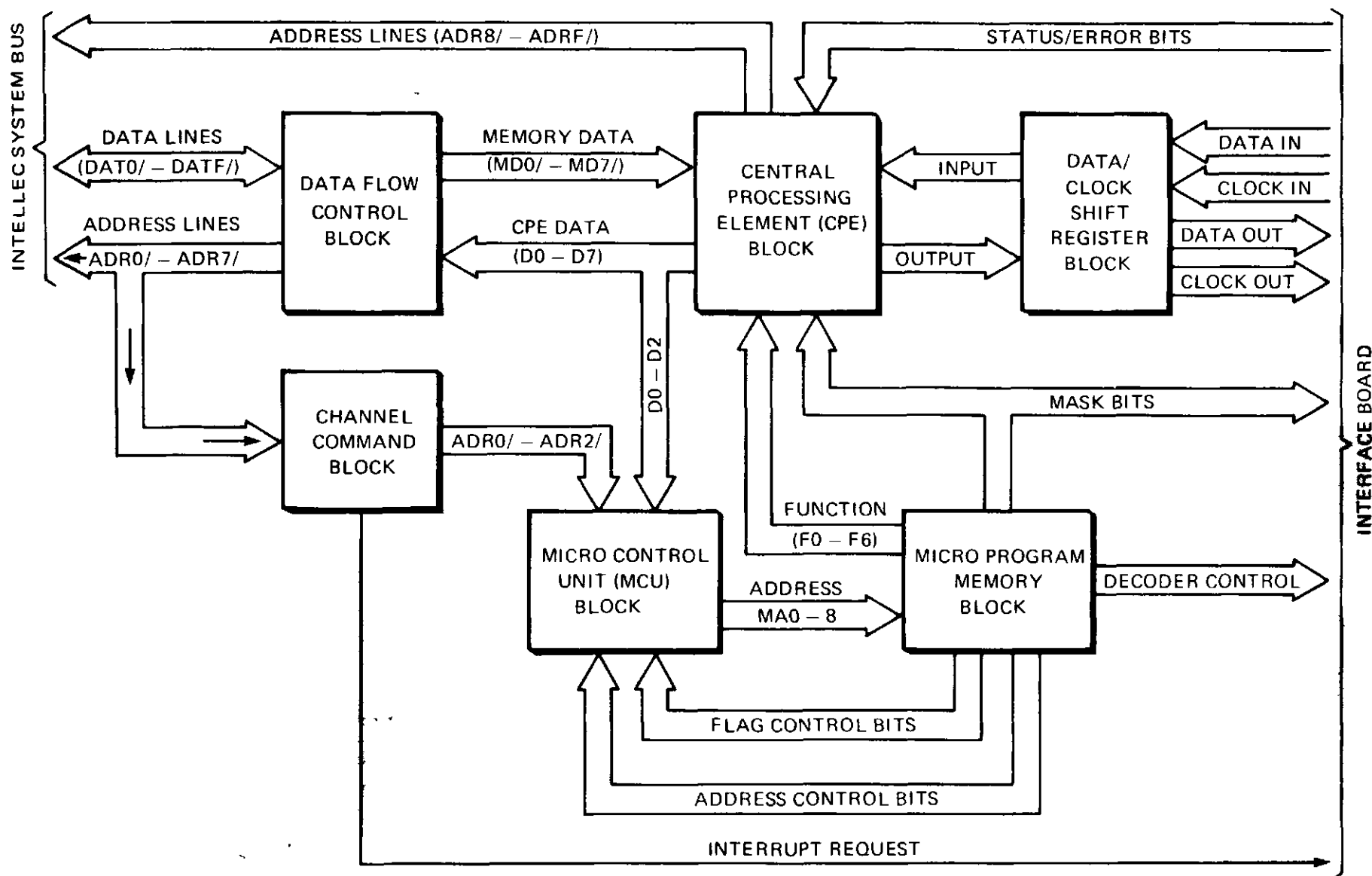

Figure 3-1 CHANNEL BOARD: FUNCTIONAL BLOCK DIAGRAM

TABLE 3-3 (CONTINUED)

-- CONTROL FUNCTION DEFINITIONS (CONTINUED) --	
RDYRS	— This pulse resets the Drive Ready flip-flops on the Interface Board.
WFLRS	— This level generates the write fault reset pulse to the selected drive.
GTR43	— This pulse sets the low current mode for writes on tracks greater than 4310.
NGT43	— This pulse resets the low current mode for writes on tracks equal to or less than 4310.

TABLE 3-4 I-BUS SELECTION BY MASK FIELD BITS

MASK BITS	INPUT FIELDS*			
	DATA SHIFT REGISTER (A36 and A29) OUTPUTS	CLOCK SHIFT REGISTER (A34 and A27) OUTPUTS	ERROR LINES (DOR, WRT PROT, WRT ERR, SEL DR NRDY)	STATUS LINES (DRO, DR1, STOP, TRACK00)
M7 =	1	1	1	1
M6 =	0	0	1	1
M5 =	0	0	0	1
M4 =	1	1	0	0
M3 =	0	1	0	0

* An input field will be multiplexed into the I inputs of 3002 CPE array if the mask bits reflect the values listed for that field and if the K-Bus select line, S0 (bit 9 of the current microinstruction) is high (logical 1). Refer to Section 3.2.4 for a more complete description of the 3002 CPE array inputs.

- 3) Providing generalized inputs to the K-bus inputs of the 3002 CPE array. The mask bits are multiplexed through two 8234 multiplexer devices and into K-bus inputs of the CPE array. The selection bits are provided by S0 and S1 (bits 9–10 of the current microinstruction). Table 3–5 correlates the levels on the S0 and S1 lines with the K-bus inputs.

3.2.4 Central Processing Element (CPE) Block

The central processing element (CPE) block executes the function indicated by each microinstruction output from the microprogram memory. The CPE block includes an array of four Intel 3002 Central Processing Elements, as well as four 8234 and one 8233 eight-to-four multiplexers that provide various inputs to the CPE array, as shown on sheet 4 of the board schematic (Section 3.3).

If a 'stop diskette operation' command is being received, output 3 from the decoder goes true, asserting a low level on the SET STOP/ line (pin P2-31). The subsequent low-to-high transition on SET STOP/ clocks the stop latch reset (i.e., the active-low state). After the stop latch is sampled, the microprogram presets (i.e., clears to the non-active-high state) the latch.

If a 'reset channel' command is being received, output 7 from the decoder goes true, asserting a low level on the RESET/ line to the Interface Board (pin P2-49).

3.2.2 Micro Control Unit (MCU) Block

The micro control unit (MCU) block provides the addresses for the microprogram memory. Since the microinstructions which are fetched from microprogram memory and executed by the central processing elements define the specific functions performed by the Channel Board, the MCU block can be considered the primary source of control for the diskette controller. In addition to an Intel 3001 Microprogram Control Unit device, the MCU block includes an 8234 eight-to-four multiplexer, a 74151 eight-to-one multiplexer and a few gating circuits, as shown on sheet 3 of the board schematic (Section 3.3).

The Intel 3001 Microprogram Control Unit controls the sequence in which microinstructions are fetched from the microprogram memory. Its functions include the following:

(A functional block diagram of the 3001 MCU is shown in Figure 3-2.)

- Maintenance of the microprogram address register
- Selection of the next microinstruction based on the contents of the microprogram address register
- Decoding and testing of data supplied via several input busses to determine the microinstruction execution sequence
- Saving and testing of carry output data from the central processor (CPE) array
- Control of carry/shift input data to the CPE array
- Control of microprogram interrupts

Address control information is supplied to the 3001 at inputs AC0 – AC6. AC1 – AC6 are provided directly from bits 27 – 32 of the microinstruction currently being fetched from microprogram memory (see Section 3.2.3). The AC0 input, however, is supplied by the output of the 74151 eight-to-one multiplexer.

Five control lines from the Interface Board (AZ, INDEX, XFER REQ, TIME OUT and F), one line from the CPE block (CO) and one line from the channel command block (BUSY START) are applied to the 74151 inputs along with the AC0 bit (bit 26) from the microinstruction currently being fetched. The three select lines applied to the A, B and C inputs on the 74151 section specify which of the eight lines are actually multiplexed through to the AC0 input on the 3001 device. The three select lines are supplied by bits 14, 15 and 16 (IN0, IN1 and IN2) of the current microinstruction. Table 3-1 correlates the values in bit positions 14, 15 and 16 of the current microinstruction with the control line which is multiplexed into the AC0 input on the 3001 section.

The 'flag logic' input (F1) to the 3001 device (pin 17) is also provided by CO. The level on the CO line will reflect the 'Carry out' output from the 3002 Central Processing Element (CPE) at A21 or the 'shift right' output from the 3002 CPE at A23.

The 'clock' input (CLK) to the 3001 device (pin 19) is supplied by CLK1/ (pin P2-3) which is one of the two clock pulses generated on the Interface Board (see Chapter 4).

The load input (LD) to the 3001 (pin 36) is fed by the master reset (MR) signal from the Interface Board (pin P2-56).

Recall from Chapter 2, that the CPU specifies channel operations for the Diskette System by executing one of the seven channel commands. A channel command may be the result of either an input or output instruction to a dedicated I/O port address on the Channel Board:

- 1) Write MA Lower (output to 'BASE+1')
- 2) Write MA Upper and start I/O (output to 'BASE+2')
- 3) Stop Diskette Operation (output to 'BASE+3')
- 4) Reset Channel (output to 'BASE+7')
- 5) Read Subsystem Status (input to 'BASE+0')
- 6) Read Result Type (input to 'BASE+1')
- 7) Read Result Byte (input to 'BASE+3')

The three least significant bits (ADR0/ – ADR2/) of the 8-bit I/O address (received at pins P1-51 through P1-58) differentiate between the various input or output channel commands. The five most significant address bits (ADR3/ – ADR7/) select the Channel Board if they match the BASE address that is assigned by setting five positions of switch S1. These five switch positions each feed one input on five EXCLUSIVE-OR gates. If ADR3/ – ADR7/ match the switch-selected BASE address, the 7410 NAND gate (A31-8) is activated and, in turn, enables one of the two 3205 decoders.

If an input channel command is being received, the RD CMD line (pin P2-60) will be true, and the 3205 decoder at A20 will be enabled. Address bits ADR0 – ADR2 (once inverted) are applied to the three data inputs on the 3205 section (A0 – A2), and activate one of three inverted outputs ($\overline{O_0}$, $\overline{O_1}$ or $\overline{O_3}$), depending on the channel command. If it is 'read subsystem status' command, output 0 goes true and READ INT/ is asserted at pin P2-57. (On the Interface Board, READ INT/ is used to gate the device 0 and device 1 ready indicators onto system data bus lines 0 and 1, DAT0/ and DAT1/.) The low level on READ INT/ also enables two 8093 circuits, one of which transmits the output of the interrupt latch (INT/) to the data bit 2 line (DAT2/) of the system data bus. The other 8093 circuit transmits a low-level to the data bit 3 line (DAT3/), indicating that the diskette controller is present. INT/ is also passed to the Interface Board via pin P2-40.

If a 'read result type' command is being received, output 1 from the decoder goes true, and the RD RI/ signal is generated (pin P2-37). The low level on RD RI/ pre-sets the interrupt latch (A37-10), thus removing the active-low system interrupt request (INT/).

The interrupt latch can subsequently be clocked reset (i.e., reset to the active-low state) by a pulse on the CLK line, when the central processing element block (Section 3.2.4) determines that an 'I/O complete' or 'ready status change' interrupt should be issued (also refer to Chapter 2).

If a 'read result byte' command is being received, output 3 from the decoder will go true, and the 74175 quad latches are clocked, latching up address bits ADR0 – ADR2. The three most significant quad latch outputs are made available to the micro control unit block (Section 3.2.2), which responds to this command via a routine stored in microprogram memory. Either read result command will generate the RD RES/ signal which is used by the data flow control block (Section 3.2.6) to gate the appropriate status word onto the system data bus.

If an output channel command is being received, the WRT CMD line (pin P2-53) will be true, and the other 3205 decoder will be enabled. Address bits ADR0 – ADR2 are applied to inputs A0 – A2, causing one of the eight inverted decoder outputs to go true. If outputs 0, 1 or 2 go true, the WSUB1/ line (pin P2-48) is activated. If outputs 4, 5 or 6 from the decoder go true, the WSUB2/ line (pin P2-47) is activated. Either WSUB1/ or WSUB2/ will cause the 74175 quad latches to be clocked and latch up address bits ADR0 – ADR2, just as a 'read result byte' command did. The three most significant outputs of the quad latches are made available to the micro control unit block which responds to the 'write MA lower', the 'write MA upper and start I/O' and the 'read result byte' channel commands, using routines stored in microprogram memory. The response mechanisms for the other channel commands are implemented in hardware, not microcode.

The four 'flag logic control' inputs (FC0 – FC3) to the 3001 device are provided by bits 17 and 18 of the current microinstruction. Bit 17 is applied to both FC0 (pin 15) and FC1 (pin 16) while bit 18 is applied to FC2 (pin 13) and FC3 (pin 12).

The 'enable' (EN) and 'enable row address' (ERA) inputs to the 3001 (pins 25 and 35, respectively) are held high.

Unless the active-low master reset (MR/) signal from the Interface Board is true (low), the 'secondary instruction bus' inputs (SX0 – SX3) to the 3001 device (pins 10, 8, 6 and 5, respectively) will reflect the complement of the level on the four least significant memory address outputs (MA0 – MA3). That is, SX0 = MA0, SX1 = MA1, SX2 = MA2 and SX3 = MA3 if MR/ is false (high). If MR/ is true (low), the four SXn inputs will all be high, regardless of the state of the MAn outputs.

The four 'primary instruction bus' inputs (PX4 – PX7) to the 3001 device are fed by the four inverting outputs of the 8234 eight-to-four multiplexer (A5). The multiplexer outputs are controlled by the levels on the S0 and S1 inputs.

The A1, A2 and A3 inputs to the 8234 section are the three least significant data outputs from the central processing element (CPE) block that have been buffered and inverted; the A0 input is always high. After having fetched the diskette instruction byte from the I/O Parameter Block in system memory (see Section 2.3), the CPE block will output the three bits that specify one of the seven diskette operations onto its three least significant data outputs (D0 – D2).

Table 3-1 ACO INPUT SELECTION

Select Lines			ACO Input At 3001 MCU (Pin 39)
(Bit 14)	(Bit 15)	(Bit 16)	
0	0	0	Bit 26 of current microinstruction (ACO)
0	0	1	CO: The carry out output from the 3002 CPE at A21 or the shift right output from the 3002 CPE at A23.
0	1	0	BUSY START: Indicates that a 'write MA lower', 'write MA upper' or 'read result byte' channel command has been received.
0	1	1	F (pin P2-58): Indicates that data/clock shift registers are full during read or empty during write.
1	0	0	AZ (pin P2-41): Indicates a valid CRC check (all zeros).
1	0	1	INDEX (pin P2-42): Indicates that an index mark has been detected (i.e., the beginning of a track).
1	1	0	XFER REQ (pin P2-39): Indicates that Interface Board has requested use of the INTELLEQ MDS system bus.
1	1	1	TIMEOUT (pin P2-38): Ten millisecond pulse that is used by the microprogram for general timeouts.

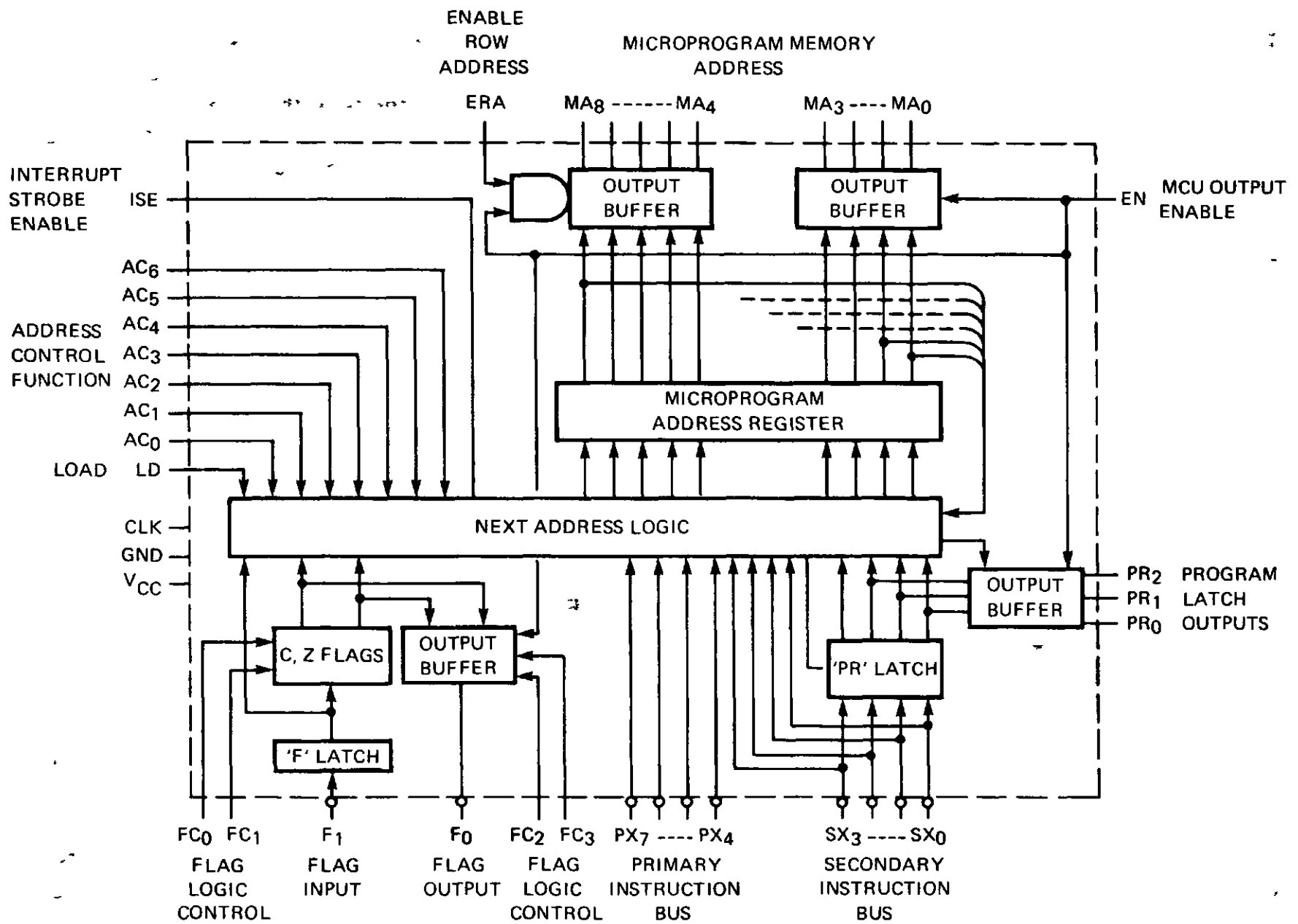

Figure 3-2 3001 MICROPROGRAM CONTROL UNIT: FUNCTIONAL BLOCK DIAGRAM

- 2) Driving the input multiplexers to the 3002 Central Processing Element (CPE) array. Four fields (data shift register, clock shift register, errors and status) are multiplexed through 8234 and 8233 multiplexer devices (see sheet 4 of the schematic) and into the I-bus inputs of the CPE array. The selection bits for the multiplexers are provided by the mask field bits, as listed in Table 3-4.

TABLE 3-2 MICROINSTRUCTION BIT ASSIGNMENTS

MICROINSTRUCTION BIT	SIGNAL	DEFINITION	PROM LOCATION – PIN
01	MASK0 (M0)	Mask field	A13- 9
02	MASK1 (M1)		A13-10
03	MASK2 (M2)		A13-11
04	MASK3 (M3)		A13-13
05	MASK4 (M4)		A13-14
06	MASK5 (M5)		A13-15
07	MASK6 (M6)		A13-16
08	MASK7 (M7)		A13-17
09	SLK0 (S0)	K-bus select	A12- 9
10	SLK1 (S1)		A12-10
11	OUT0	Decoder output select	A12-11
12	OUT1		A12-13
13	OUT2		A12-14
14	IN0	AC0 Select	A12-15
15	IN1		A12-16
16	IN2		A12-17
*17	FC0	Flag control	A11- 9
*17	FC1		A11- 9
*18	FC2		A11-10
*18	FC3		A11-10
19	F0	Function field	A11-11
20	F1		A11-13
21	F2		A11-14
22	F3		A11-15
23	F4		A11-16
24	F5		A11-17
25	F6		A10- 9
26	AC0	Address control	A10-10
27	AC1		A10-11
28	AC2		A10-13
29	AC3		A10-14
30	AC4		A10-15
31	AC5		A10-16
32	AC6		A10-17

*Bit 17 drives FC0 and FC1; bit 18 drives FC2 and FC3

At this time, the mask and output bits of the current microinstruction being output from the microprogram memory block (see Section 3.2.3) will produce a high level on the S0 input to the 8234 section and a low level on the S1 input, multiplexing the inverted levels of the 8234's A inputs (specifying a particular diskette operation) into the PX4 – PX7 inputs on the 3001 MCU. This allows the 3001 MCU to subsequently access those microinstructions which will effect the appropriate diskette operation.

The B1, B2 and B3 inputs to the 8234 multiplexer are the three least significant system address bits that were buffered and inverted in the channel command block (see Section 3.2.1); the B0 input is always held low. Recall that these three address bits specify one of the seven channel commands. At this time, the mask and output bits of the current microinstruction being output from the microprogram memory block (see Section 3.2.3) will produce a low level on the S0 input to the 8234 section, multiplexing the inverted levels of the 8234's B inputs (specifying a particular channel command) into the PX4 – PX7 inputs on the 3001 MCU. This allows the 3001 MCU to subsequently access those microinstructions which will produce the proper Diskette System response to the channel command received.

The MCU outputs the 9-bit address of the next microinstruction to be fetched on MA0 – MA8. MA0 – MA8 are applied to the nine address inputs on each of the 3604 PROM's that constitute the microprogram memory (see Section 3.2.3).

3.2.3 Microprogram Memory Block

The microprogram memory block stores the microinstructions which direct the operation of the diskette controller. The microprogram memory block consists of four 3604 programmable-read-only-memory devices (512 x 8 bits each), which store 32 bit microinstructions; a 3205 three-to-eight decoder, which generates eight timing control pulses (DEC OUT0 – DEC OUT7) based on bits 11, 12 and 13 (OUT0 – OUT2) of the current microinstruction; and a 3404 six-bit high speed latch, which provides various control signal levels based on the decoder outputs mentioned above and the mask bit field of the current microinstruction; as shown on sheet 3 of the board schematic (Section 3.3).

The 9-bit memory address (MA0 – MA8) for the four 3604 PROM's is provided by the 3001 Microprogram Control Unit. MA0 – MA8 cause the addressed microinstruction to appear on the 32 output lines from the four PROM's.

Table 3-2 summarizes bit definitions for the 32-bit microinstructions. The address control bits, AC0 – AC6 (bits 26–32), the flag control bits (bits 17 and 18), and the input control bits used for AC0 select (bits 14–16) are fed to the micro control unit block as described in Section 3.2.2. The function field bits, F0 – F6 (bits 19–25), the mask bits M0 – M7 (bits 1–8) and the K-bus select bits S0 and S1 (bits 9–10) are applied to the central processing element (CPE) block, as described in Section 3.2.4. The output bits OUT0 – OUT2 (bits 11–13) are applied to the three address inputs on a 3205 decoder. The enable inputs to this 3205 section are provided by the CLK2/ pulse from the Interface Board (pin P2–30), the seventh mask bit M7 (bit 8 of the current microinstruction) and S0, one of the two K-bus select bits mentioned above (bit 9 of the current microinstruction). The eight decoder outputs, DEC OUT0 – DEC OUT7, provide timing control pulses that, when used with the mask bits, provide overall control for the diskette controller (see Table 3–3).

The mask field bits M0 – M7 (bits 1–8 of the current microinstruction) are actually used for three disjoint functions in the Diskette System:

- 1) Generating control signals for the hardware. These control signals are pulses (positive or negative and of 50–75 nsec. duration) or levels. The pulses are generated by gating the appropriate mask bit with one of the 3205 decoder outputs (DEC OUTn). The levels are derived by using the DEC OUTn outputs to strobe 3404 six-bit latches. The DEC OUTn outputs provide the write enable strobes to the 3404 latches, while the mask bits provide the data inputs and, consequently, the actual controls. Refer to Table 3–3 for a summary of the control pulses and levels generated by the DEC OUTn strobes and mask field bits.

TABLE 3-3 (CONTINUED)

-- CONTROL FUNCTION DEFINITIONS (CONTINUED) --		
SROUT	—	This level enables data bits from data register (when high) or from 9401 CRC device (when low) to be sent to the selected diskette.
LDADM	—	This level is used to load clock shift register with the bit patterns required to write the different address marks onto a diskette.
CRCMD	—	This level indicates the operating mode for the 9401 CRC device on the Interface Board.
DIREC	—	This level indicates the direction of head movement for the selected diskette drive.
AMWRT	—	This level enables writing of an extra clock pulse and is activated during writing of an address mark.
LOWEN	—	This level drives the GATE LOWER line that enables data onto the memory data inputs (M0/ — M7/) to the CPE array.
MEMWT	—	This level indicates when the Diskette System wishes to write data to memory.
SMREQ	—	This pulse initiates the bus request sequence intended to gain master control of the INTELLEC MDS system bus.
STBDU	—	This pulse loads CPE data outputs (D0 — D7) into the latch which drives the system data lines, DATA8/ — DATAF/.
STBDL	—	This pulse loads CPE data outputs (D0 — D7) into the latch which drives the system data bus lines, DATA0/ — DATA7/.
LDADD	—	This pulse loads CPE data outputs (D0 — D7) into the latch which drives the system address bus lines, ADR0/ — ARD7/.
SINTR	—	This pulse is used to generate a signal which clocks the interrupt latch on the Channel Board.
CINBS	—	This pulse is used to latch data from the system data bus into the latches which drive M0 — M7/ of the CPE array.
CSYNC	—	This pulse initializes the synchronization logic prior to detecting an address mark.
RSAMD	—	This pulse resets the synchronization logic prior to initializing the logic with the CSYNC pulse.
UNLHD	—	This pulse clears the LOAD latch on the Interface Board, and ultimately causes the read/write head on the selected drive to be unloaded.
RSTST	—	This pulse is used to generate CLR START STOP signal which resets the STOP latch and the 74145 latch at A8-1 on the Channel Board.
RNDX	—	This pulse resets the INDEX latch on the Interface Board.
LDOPC	—	This pulse latches diskette operation code (D0—D5) and makes latched code available to 'primary instruction bus' multiplexer.

TABLE 3-3 CONTROL PULSES AND LEVELS GENERATED BY MICROPROGRAM

OUT CODE (DEC OUT n) MASK BIT	000 (0)	001 (1)	010 (2)	011 (3)	100 (4)	101 (5)	110 (6)	111 (7)
M0	CSTEP		NSUB0			AMWRT	SMREQ	CSYNC
M1	SSCLK	RDYRS	NSUB1			WFLRS	STBDU	RSAMD
M2	LDHD			LDNXM			STBDL	UNLHD
M3		RINH				LOWEN	LDADD	RSTST
M4		SINH		WTGTN		MEMWT	GTR43	NGT43
M5		SACK		SR OUT	CRC MD		SINTR	RNDX
M6		RDOR		LDADM	DIREC		CINBS	LDOPC

— — CONTROL FUNCTION DEFINITIONS — —

CSTEP	—	This pulse triggers the one-shot which drives the STEP/ line to the diskette drives. STEP/ causes the selected drive to move its head one track.
SSCLK	—	This pulse triggers the TIMEOUT one-shot. TIMEOUT provides a 10 msec. pulse for use by the microprogram.
LDHD	—	This pulse sets the LOAD latch on the Interface Board which causes the read/write head on the selected unit to be loaded.
RINH	—	This pulse resets the inhibit memory write latch (A48-1).
SINH	—	This pulse sets the inhibit memory write latch (A48-4).
SACK	—	This pulse sets the transfer acknowledge (XACK/) latch on the Interface Board.
RDOR	—	This pulse resets the data overrun latch on the Interface Board.
NSUB0 and NSUB1	—	These levels select 'primary instruction bus' inputs to 3001 MCU.
LDNXM	—	This level is used to load the clock shift register with the bit patterns required to write the different address marks onto a diskette.
WTGTN	—	When the data and clock shift registers are empty, this level allows both shift registers to be parallel loaded with information that will be serially shifted out to the Interface Board and then to the diskette. Used to generate PE/ and WRT GT/ signals.

An Intel 3002 Central Processing Element contains all of the circuits that represent a 2-bit wide slice through the data processing section of a digital computer. When wired together in an array, a set of CPE's provide the following capabilities:

- Two's complement arithmetic
- Logical AND, OR, NOT and EXCLUSIVE-OR
- Incrementing and decrementing
- Shifting left or right
- Bit testing and zero detection
- Carry look-ahead generation
- Multiple data and address busses

A functional block diagram of a 3002 CPE is shown in Figure 3-3.

TABLE 3-5 K-BUS INPUT SELECTION

K-BUS SELECT LINES		K-BUS INPUTS TO 3002 CPE ARRAY							
S1 (Bit 10)	S0 (Bit 9)	K0	K1	K2	K3	K4	K5	K6	K7
0	0	M0	M1	M2	M3	M4	M5	M6	M7
0	1	1	1	1	1	1	1	1	1
1	1	0	0	0	0	0	0	0	0

Note that only when S0 and S1 equal zero will the K-bus inputs be supplied by the mask bits; otherwise, the K-bus inputs will be all ones or all zeros.

During each micro-cycle, the function field of the current microinstruction is applied to the F-bus inputs (F0 – F6) of each 3002 CPE. The function bits are decoded, the operands are selected by the internal multiplexers, and the specified operation is performed. Within each CPE, data is stored in eleven scratchpad registers or the accumulator.

Data being output from the CPE array is carried on the address bus (A0 – A7) or the data out bus (D0 – D7). The address outputs drive the eight most significant lines of the INTELLEC System address bus, ADR8 – ADRF. The data outputs are made available to the data flow control block (Section 3.2.6) and the micro control unit block (Section 3.2.2).

Data is brought into the CPE array on three separate input buses, the memory data bus (M0 – M7), the I-bus (I0 – I7) and the K-bus (K0 – K7). The memory data inputs are supplied by the data flow control block (Section 3.2.6) which routes data from the system data bus to the CPE array. The latter two buses are driven by five multiplexers.

The K-bus inputs (K0 – K7) are driven by two 8234 eight-to-four multiplexers (located at A33 and A26). The S0 and S1 outputs from the microprogram memory (bits 9 and 10 of the current microinstruction) determine the four outputs on each of the two 8234 sections. If S0 = 1 and S1 = 0, all eight inverted outputs will be low. If S0 = 1 and S1 = 1,

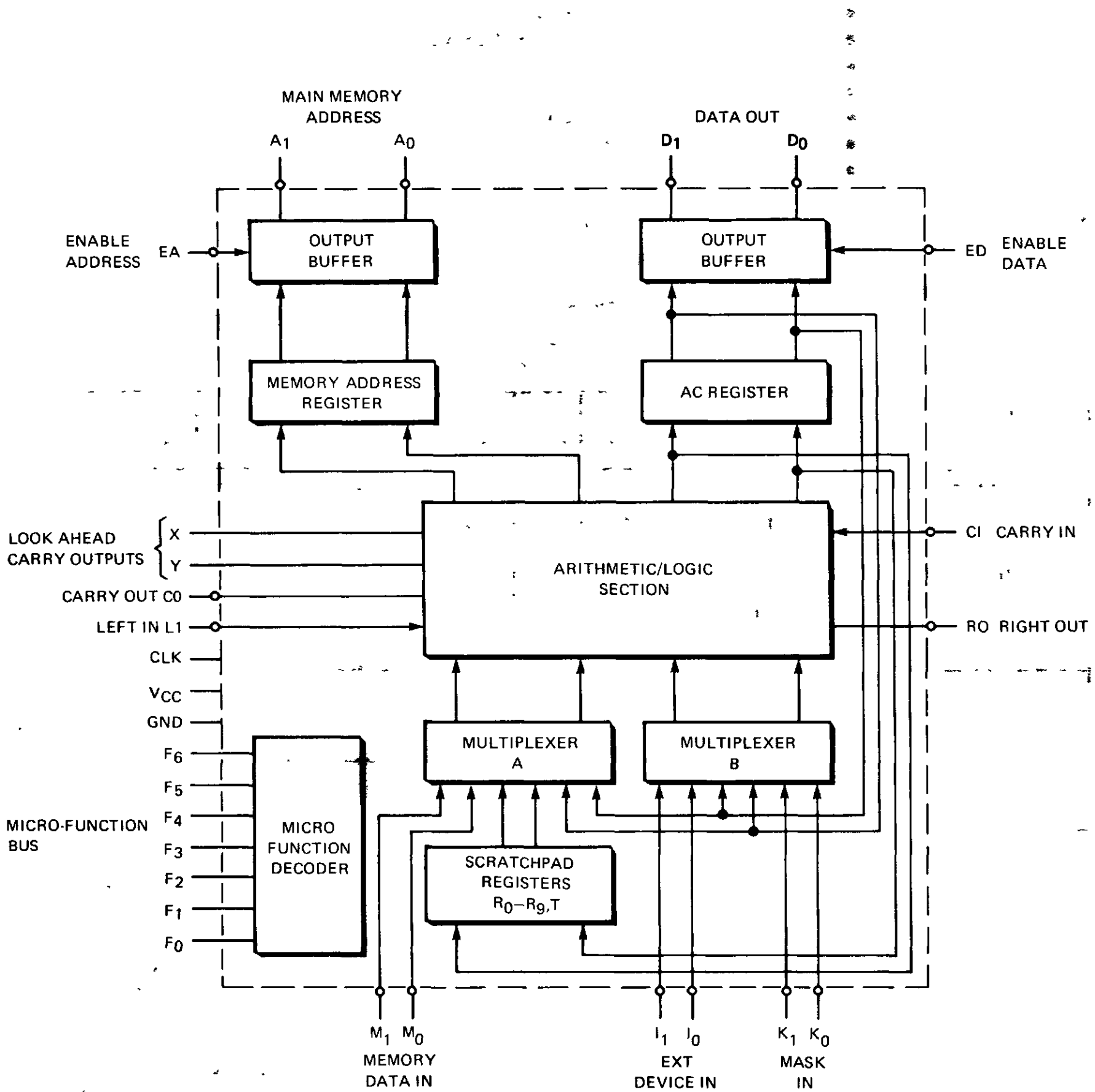

Figure 3-3 3002 CENTRAL PROCESSING ELEMENT: FUNCTIONAL BLOCK DIAGRAM

all eight outputs will be high. If $S0 = 0$, however, the eight mask bits, $M0 - M7$, from the microprogram memory (bits 01 - 08 of the current microinstruction) will be inverted and applied to the K-bus inputs of the CPE array (see Table 3-5).

The I-bus inputs (I0 - I7) are driven by two 8234 (inverting outputs) and one 8233 (non-inverting outputs) eight-to-four multiplexers (located at A28, A45 and A35). Mask bits $M3 - M7$ from the microprogram memory (bits 04 - 08 of the current microinstruction) determine the I-bus inputs as listed in Table 3-4 of Section 3.2.3. These mask bits will enable the eight outputs from the two 4-bit data shift registers (at A36 and A29), or the eight outputs from the two clock shift registers (at A34 and A27) through the 8233 section and one of the 8234 sections and into the I0 - I7 inputs on the CPE array. The mask bits can also enable the four error lines (DOR, WRT PROT, WRT ERR and SEL DR NRDY) or the four status lines (DR0, DR1, STOP and TRACK 00) from the Interface Board (see Chapter 4) through the other 8234 section (at A45) and into the I4 - I7 inputs on the CPE array.

The clock input to the 3002 CPE's is provided by the CLK1/ pulse generated on the Interface Board. The enable address inputs (EA), which enable the address outputs (A0 - A7), are fed by the SELECTED line from the Interface Board (pin P2-43). When true, SELECTED indicates that the diskette controller has master control of the INTELLEC MDS bus (see Chapter 4). The enable data input (ED) to each 3002 CPE is permanently held low (active).

The carry output (CO) from each 3002 CPE feeds the carry input (CI) of the adjacent 3002 CPE. Likewise, the shift right output (RO) feeds the shift right input (LI) of the adjacent 3002 CPE. The carry output (CO) from the most significant CPE (A21-7) feeds its own shift right input (LI) and is wire-ORed with the shift right output (RO) from the least significant CPE (A23-8) to form the CO line, which is applied to the flag control input (FI) on the 3001 Microprogram Control Unit. CO is also inverted and applied to the D1 input on the 74151 multiplexer (A30-3) which provides the least significant address control bit, AC0, to the 3001 MCU. The carry input (CI) to the least significant 3002 CPE (A23-10) is provided by the flag control output (FO) from the 3001 MCU.

3.2.5 Data/Clock Shift Register Block

During read operations, the data/clock shift register (SR) block accepts serial data and clock bits that the Interface Board has received from the selected diskette drive and converts them into eight bit bytes that are input, in parallel, to the CPE array. During write operations, the shift registers are parallel loaded with data and clock bytes which are then shifted out to the Interface Board. This block includes four 9300 four-bit shift registers, as shown on sheet 4 of the board schematic (see Section 3.3).

Recall from Section 1.2 that data and clock bits are interspersed when information is written on disk. When that information is later read, the diskette drive separates the data and clock pulses before passing them to the Interface Board (see Chapter 4).

The Interface Board, in turn, sends the data bits to the Channel Board via the SR DATA IN/ line (pin P2-22) along with the data strobe SR DATA STB (pin P2 - 24). SR DATA IN/ feeds the J and \bar{K} inputs on the first data shift register at A36. The Q3 output from this first shift register then feeds the J and \bar{K} inputs on the shift register at A29. When the data shift registers are full, the eight data bits are transferred in parallel to the CPE array. The four outputs from the first data shift register (A36) are applied to the 'A' inputs on the 8233 multiplexer that feeds the four least significant I-bus inputs to the CPE array. The first two outputs are also made available to the Interface Board via the ID0/ (pin P2-26) and ID1/ (pin P2-23) lines (see Chapter 4). The four outputs from the second data shift register (A29) are applied to the 8234 multiplexer (A28) that feeds the four most significant bits of the I-bus inputs to the CPE array. Both data shift registers are clocked by SR DATA STB.

During write operations, both data shift registers can be parallel loaded when the PE/ input is low. PE/ will go low when the shift register is empty and the WTGTN signal is true (see Table 3-3).

The parallel inputs to the first data shift register (A36) are supplied by the four least significant data outputs from the CPE array, as follows:

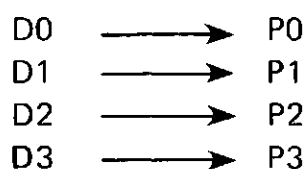

The parallel inputs to the second data shift register (A29) are supplied by the four most significant CPE array data outputs:

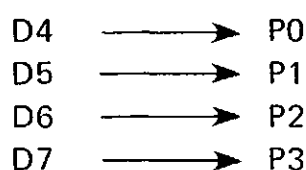

The data bits can then be shifted out, in serial, to the Interface Board via the SR DATA OUT line (pin P2-25) which is driven by the $\overline{Q3}$ output on the second data shift register.

During read operations, the Interface Board sends the clock bits (that were interleaved with the data bits on the diskette) to the Channel Board via the SR CLK IN/ line (pin P2-6) along with the clock strobe, CLK SR STB (pin P2-8). SR CLK IN/ feeds the J and \overline{K} inputs on the first clock shift register at A34. The Q3 output of this first clock shift register then feeds the J and \overline{K} inputs on the shift register at A27. When the clock shift registers are full, the eight clock bits can be transferred in parallel to the CPE array. The four outputs from the first clock shift register (A34) are applied to the 'B' inputs on the 8233 multiplexer that feeds the four least significant bits of the I-bus to the CPE array. The four outputs from the second clock shift register (A27) are applied to the 8234 multiplexer that feeds the four most significant bits of the I-bus. Both clock shift registers are clocked by CLK SR STB.

During write operations, both clock shift registers can be parallel loaded when the PE/ signal (described above) is low. The P0, P1 and P2 inputs to the first clock shift register and the P2 and P3 inputs to the second clock shift register are tied to ground. The P3 input to the first shift register and the P1 input to the second are both fed by the output of a 7408 AND gate (A7-6) shown on sheet 3 of the schematic. The inputs to this gate are the LDNXM and LDADM control levels which have been set in the 3404 latches at A16 by the microprogram (refer to Table 3-3). The P0 input to the second clock shift register is fed by the LDADM control output. LDNXM and LDADM allow the microprogram to produce the varied patterns of clock bits that are required to write the different types of address marks onto a diskette (refer to Section 1.2).

3.2.6 Data Flow Control Block

The data flow control block routes data to/from the various other functional blocks within the Channel Board. This block consists of five 8212 bi-directional latching bus drivers, a 3404 six-bit latch and various gating circuits, as shown on sheet 2 of the board schematic (Section 3.3).

The six least significant data outputs (D0 - D5) from the CPE array are applied to the inputs of the 3404 six-bit latch. When the microprogram generates the LDOPC control pulse (see Table 3-3), D0 - D5 are latched and inverted. $\overline{D0}$ - $\overline{D2}$ are made available to the 'primary instruction bus' multiplexer (A5) in the MCU block. $\overline{D3}$ is used for 16-bit data flow control as described below. $\overline{D4}$ and $\overline{D5}$ are sent to the Interface Board as the unit select signals, USA (pin P2-9) and USB (pin P2-12), respectively.

All eight CPE data outputs, D0 - D7, are also applied to three of the 8212 latching bus drivers. D0 - D7 are loaded into the 8212 device at A41 when the microprogram generates the LDADD control pulse (see Table 3-3). The 8212

device at A41 drives the eight least significant lines of the system address bus, ADR0/ – ADR7/. When the microprogram generates the STBDL control pulse (see Table 3-3), D0 – D7 are latched into the 8212 device at A43 which drives the eight least significant lines of the system data bus, DAT0/ – DAT7/ (pins P1 – 67 through P1 – 74). STBDL is generated when the microprogram is setting a result word or preparing write data. When the microprogram generates the STBDU control pulse (see Table 3-3), D0 – D7 are latched into the 8212 device at 42, which drives the eight most significant system data bus lines, DAT8/ – DATF/ pins P1 – 59 through P1 – 66). STBDU would only be generated if the Diskette System were operating in the 16 bit mode. The address latch (A41) is gated onto the MDS system bus whenever the SELECTED signal is true. The high-order data latch (A42) is gated onto the bus whenever the SELECTED, MEMORY WRITE and 16-BIT MODE signals are true. The low-order data latch (A43) is gated onto the bus during memory write operations or 'read result' operations.

When a master bus module in the INTELLEC System outputs data to the diskette controller, the data from lines DAT0/ – DAT7/ is applied to the 8212 bus driver at A25. DAT8/ – DATF/ is applied to the 8212 at A24. The data on those lines are strobed into the input latches at A24 and A25 by the microprogram control pulse CINBS (see Table 3-3). 'Slave' memory modules also drive the data lines, DAT0/ – DAT7/ and possibly DAT8/ – DATF/. Memory data are strobed into the latches when the STB MEM IN signal is generated by the Interface Board. The outputs from the devices at A24 and A25 are 'OR-ed' into lines M0/– M7/. Depending on the state of the GATE LOWER signal, data from only one of the two latches will actually be gated onto the M input lines (M0/ – M7/) to the CPE array.

3.3 SCHEMATICS/PIN LISTS: CHANNEL BOARD

The schematic drawing (4 sheets) for the Channel Board is provided in Figure 3-4. These schematics are subject to change without notice. The Reference Schematic Drawings shipped with the Diskette System should be used as a reference.

Table 3-6 lists the pins and designated signal functions for the 86-pin P1 bus connector. Table 3-7 lists the same information for the 60-pin P2 controller connector.

TABLE 3-6 PIN LIST: P1 BUS CONNECTOR

PIN	SIGNAL	FUNCTION
1		
2		
3		
4		
5		
6		
7		
8		
9		
10		
11		
12		
13		
14		
15		
16		
17		
18		

TABLE 3-6 PIN LIST: P1 BUS CONNECTOR (CONTINUED)

PIN	SIGNAL	FUNCTION
19 20 21 22 23 24 25 26 27 28 29 30 31 32 33 34 35 36 37 38 39 40 41 42	 <p>NO CONNECTION</p>	
43 44 45 46 47 48 49 50 51 52 53 54 55 56 57 58	ADRE/ ADRF/ ADRC/ ADRD/ ADRA/ ADRB/ ADR8/ ADR9/ ADR6/ ADR7/ ADR4/ ADR5/ ADR2/ ADR3/ ADR0/ ADR1/	INTELLEC System address bus
59 60 61 62 63 64 65 66 67 68 69 70	DATAE/ DATAF/ DATAC/ DATAD/ DATAA/ DATAB/ DATA8/ DATA9/ DATA6/ DATA7/ DATA4/ DATA5/	INTELLEC System data bus

TABLE 3-6 PIN LIST: P1 BUS CONNECTOR (CONTINUED)

PIN	SIGNAL	FUNCTION
71	DATA2/	INTELLEC System data bus
72	DATA3/	
73	DATA0/	
74	DATA1/	
75	 NO CONNECTION	
76		
77		
78		
79		
80		
81		
82		
83		
84		
85		
86		

TABLE 3-7 PIN LIST: P2 CONTROLLER CONNECTOR

PIN	SIGNAL	FUNCTION
1	—	—
2	MK4	Mask bit 4
3	CLK1/	Diskette controller clock 1
4	MK1	Mask bit 1
5	—	—
6	SR CLK IN 1	Serial clock input line
7	—	—
8	CLK SR STB	Serial clock strobe
9	USA	Unit select bit A
10	SR CLK OUT	Serial clock out line
11	TRACK 00/	Track 00 detected
12	USB	Unit select bit B
13	MK0	Mask bit 0
14	DSK WRT PROT/	Disk write protected
15	DRO/	Drive 0 ready
16	DOR/	Data overrun error
17	DR1/	Drive 1 ready
18	WRT ERR/	Write error
19	SR OUT	Write data multiplexer control level
20	SEL DR NRDY/	Selected drive not ready

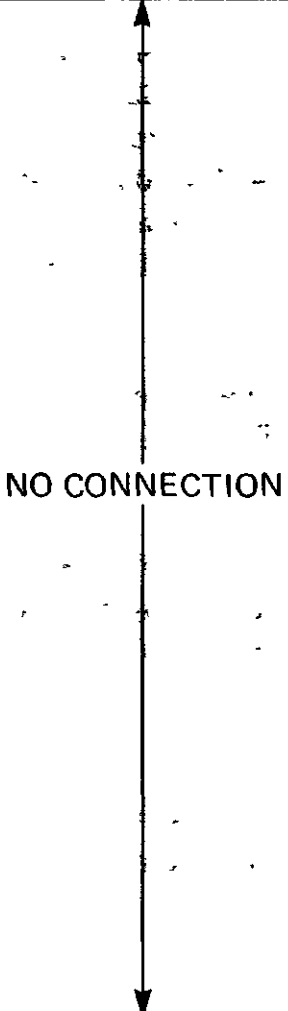
PIN LIST: P2 CONTROLLER CONNECTOR (CONTINUED)

PIN	SIGNAL	FUNCTION
21	DEC OUT 0/	Control decoder output 0
22	SR DATA IN/	Serial data in line
23	ID1/	Input data bit 1
24	DATA SR STB	Serial data strobe
25	SR DATA OUT	Serial data out line
26	ID0/	Input data bit 0
27	DEC OUT 5/	Control decoder 5 output
28	DEC OUT 4/	Control decoder 4 output
29	STB MEM IN	Strobe memory data in
30	CLK2/	Diskette controller clock 2
31	SET STOP/	'Stop diskette' channel command
32	ENABLE	Diskette controller addressed
33	DEC OUT 7	Control decoder output 7
34	MK3	Mask bit 3
35	DEC OUT 6	Control decoder output 6
36	MK6	Mask bit 6
37	RD RI/	'Read result type' channel command
38	TIME OUT	10 msec. timing pulse
39	XFER REQ/	Controller requests MDS bus
40	INT/	Interrupt line
41	AZ	All zeros, valid CRC check
42	INDEX	Index mark detected
43	SELECTED	Controller has control of MDS bus
44	GATE LOWER	Input low order data byte
45	BUSY START	Microprogram responding to channel command
46	MR/	Master reset
47	WSUB2/	Not used at present
48	WSUB1/	Not used at present
49	RESET/	'Reset' channel command
50	MK2	Mask bit 2
51	MEM WRT	Write data to MDS memory
52	DEC OUT 1/	Control decoder output 1
53	WRT CMD	I/O write command
54	MK5	Mask bit 5
55	WRT GT	Write gate control level
56	MR	Master reset
57	RD INT/	'Read subsystem status' command
58	F	Shift registers are full or empty
59	—	—
60	RD CMD	I/O read command

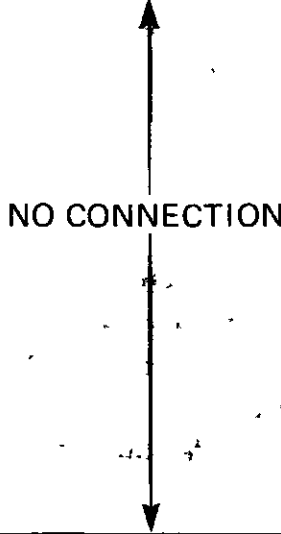
REVISIONS		
REV	DESCRIPTION	SIGNATURE AND DATE
REV	DESCRIPTION	DATE
1	INITIAL RELEASE	DTI ENR 1/11/82
2	ADD 24LS164	DTI ENR 1/11/82
3	SEE ECD 000910-2	DTI ENR 1/11/82
4	SEE ECD 000910	DTI ENR 1/11/82
5	SEE ECD 000910-1	DTI ENR 1/11/82
6	SEE ECD 000910-1	DTI ENR 1/11/82

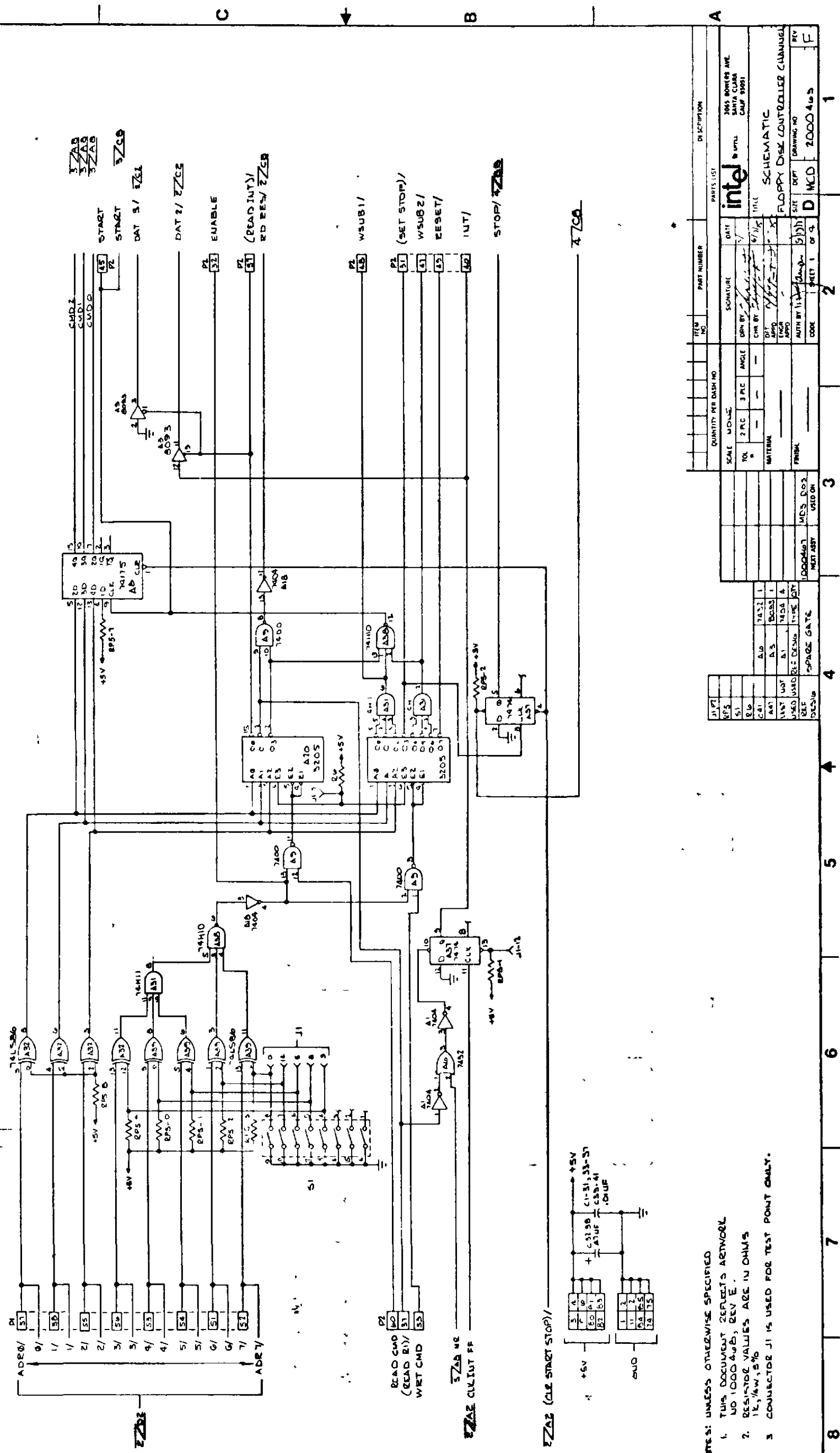

- NOTES: UNLESS OTHERWISE SPECIFIED
1. THIS DOCUMENT REFLECTS ARTWORK NO 1000408, REV E.
 2. RESISTOR VALUES ARE IN OHMS 1%, 1/4W, 5%
 3. CONNECTOR J1 IS USED FOR TEST POINT ONLY.

ITEM NO	PART NUMBER	DESCRIPTION
1	74LS164	74LS164
2	74LS10	74LS10
3	74LS13	74LS13
4	74LS193	74LS193
5	74LS00	74LS00
6	74LS04	74LS04
7	74LS08	74LS08
8	74LS09	74LS09
9	74LS14	74LS14
10	74LS15	74LS15
11	74LS16	74LS16
12	74LS17	74LS17
13	74LS18	74LS18
14	74LS19	74LS19
15	74LS20	74LS20
16	74LS21	74LS21
17	74LS22	74LS22
18	74LS23	74LS23
19	74LS24	74LS24
20	74LS25	74LS25
21	74LS26	74LS26
22	74LS27	74LS27
23	74LS28	74LS28
24	74LS29	74LS29
25	74LS30	74LS30
26	74LS31	74LS31
27	74LS32	74LS32
28	74LS33	74LS33
29	74LS34	74LS34
30	74LS35	74LS35
31	74LS36	74LS36
32	74LS37	74LS37
33	74LS38	74LS38
34	74LS39	74LS39
35	74LS40	74LS40
36	74LS41	74LS41
37	74LS42	74LS42
38	74LS43	74LS43
39	74LS44	74LS44
40	74LS45	74LS45
41	74LS46	74LS46
42	74LS47	74LS47
43	74LS48	74LS48
44	74LS49	74LS49
45	74LS50	74LS50
46	74LS51	74LS51
47	74LS52	74LS52
48	74LS53	74LS53
49	74LS54	74LS54
50	74LS55	74LS55
51	74LS56	74LS56
52	74LS57	74LS57
53	74LS58	74LS58
54	74LS59	74LS59
55	74LS60	74LS60
56	74LS61	74LS61
57	74LS62	74LS62
58	74LS63	74LS63
59	74LS64	74LS64
60	74LS65	74LS65
61	74LS66	74LS66
62	74LS67	74LS67
63	74LS68	74LS68
64	74LS69	74LS69
65	74LS70	74LS70
66	74LS71	74LS71
67	74LS72	74LS72
68	74LS73	74LS73
69	74LS74	74LS74
70	74LS75	74LS75

Figure 3-4 SCHEMATIC DRAWING: CHANNEL BOARD (Sheet 1 of 4)

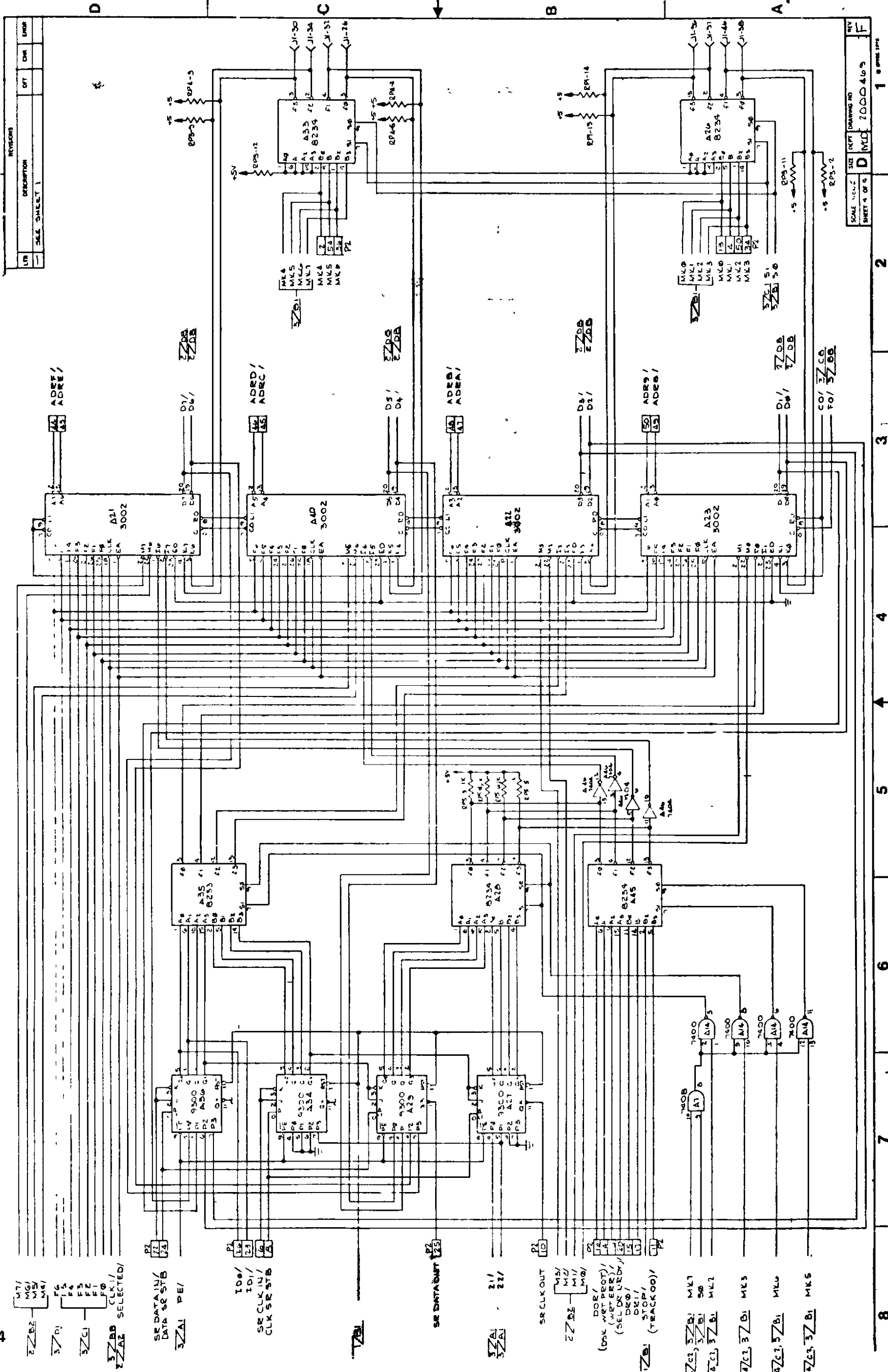

Figure 3-4 SCHEMATIC DRAWING: CHANNEL BOARD (Sheet 4 of 4)

REV	1	0	0	0	0	0	0	0	0
SCALE	1:1								
SIZE	11.0								
DEPT	11.0								
DRAWING NO	11.0								
REV	1								

REV	1								
SCALE	1:1								
SIZE	11.0								
DEPT	11.0								
DRAWING NO	11.0								
REV	1								

REV	1								
SCALE	1:1								
SIZE	11.0								
DEPT	11.0								
DRAWING NO	11.0								
REV	1								

REV	1								
SCALE	1:1								
SIZE	11.0								
DEPT	11.0								
DRAWING NO	11.0								
REV	1								

REV	1								
SCALE	1:1								
SIZE	11.0								
DEPT	11.0								
DRAWING NO	11.0								
REV	1								

REV	1								
SCALE	1:1								
SIZE	11.0								
DEPT	11.0								
DRAWING NO	11.0								
REV	1								

REV	1								
SCALE	1:1								
SIZE	11.0								
DEPT	11.0								
DRAWING NO	11.0								
REV	1								

REV	1								
SCALE	1:1								
SIZE	11.0								
DEPT	11.0								
DRAWING NO	11.0								
REV	1								

REV	1								
SCALE	1:1								
SIZE	11.0								
DEPT	11.0								
DRAWING NO	11.0								
REV	1								

CHAPTER 4

INTERFACE BOARD

The Interface Board provides the Diskette Channel with a means of communicating with the diskette drives, as well as with the INTELLEC System bus. Under control of the microprogram being executed on the Channel Board, the Interface Board generates those signals which cause the read/write head on the selected drive to be loaded (i.e., to come in contact with the diskette platter), then cause the head to move to the proper track. The Interface Board accepts the data being read off the diskette, interprets certain synchronizing bit patterns, checks the validity of the data using a cyclic redundancy check (CRC) polynomial, and passes the data to the Channel Board.

During write operations, the Interface Board outputs the data and clock bits to the selected drive at the proper times. It also generates CRC characters which are appended to the data; this allows the data to be verified when it is subsequently read.

When the Diskette Channel requires access to INTELLEC System memory, the Interface Board requests and maintains master control of the system bus, and generates the appropriate memory command.

When a CPU in the INTELLEC System issues a channel command to the diskette controller, the Interface Board acknowledges the command as required by INTELLEC System bus protocol.

The Interface Board resides within the INTELLEC System cabinet. The Interface Board, together with the Channel Board, constitute what we refer to as the Diskette Channel.

4.1 FUNCTIONAL ORGANIZATION OF THE INTERFACE BOARD

For descriptive purposes, the circuitry on the Interface Board can be divided into five functional blocks: (As shown in Figure 4-1)

- Disk drive control block
- Serial data/clock synchronization block
- Write clock generator block
- Cyclic Redundancy Check (CRC) block
- Bus control block

The DISK DRIVE CONTROL BLOCK provides the unit selection/head loading (SELn/) signal, the direction indicator (DIR/) and the step pulse (STEP/) that moves the read/write head on the selected unit one track in the specified direction. The disk drive control block also monitors the READY status, the INDEX indicator and the TRACK0 indicator from the drives.

The SERIAL DATA/CLOCK SYNCHRONIZATION BLOCK receives the unseparated data, separates the data and clock bits with a phase locked loop, and examines the bit patterns looking for specific patterns which indicate an address mark. Address marks precede address and data fields and are used to synchronize the controller with the drive. The synchronization block then generates data and clock strobes (DATA SR STB and CLK SR STB) which shift the data and clock bits into the shift registers on the Channel Board. The synchronization block also includes a bit counter that determines when a byte (8-bits) has been shifted to/from the selected drive.

The WRITE CLOCK GENERATOR BLOCK provides double density encoding and timing references for the writing of data and clock bits. Data and clock bits are both output to the drive via the WRT DAT/ line. This write clock generator includes timing precompensation circuitry to anticipate bit shifting which occurs upon readback of the double density bit patterns.

The CRC BLOCK generates two CRC characters (16 bits) which are appended to the end of each address field and data field during format and write data operations. During read operations, the CRC block generates two CRC

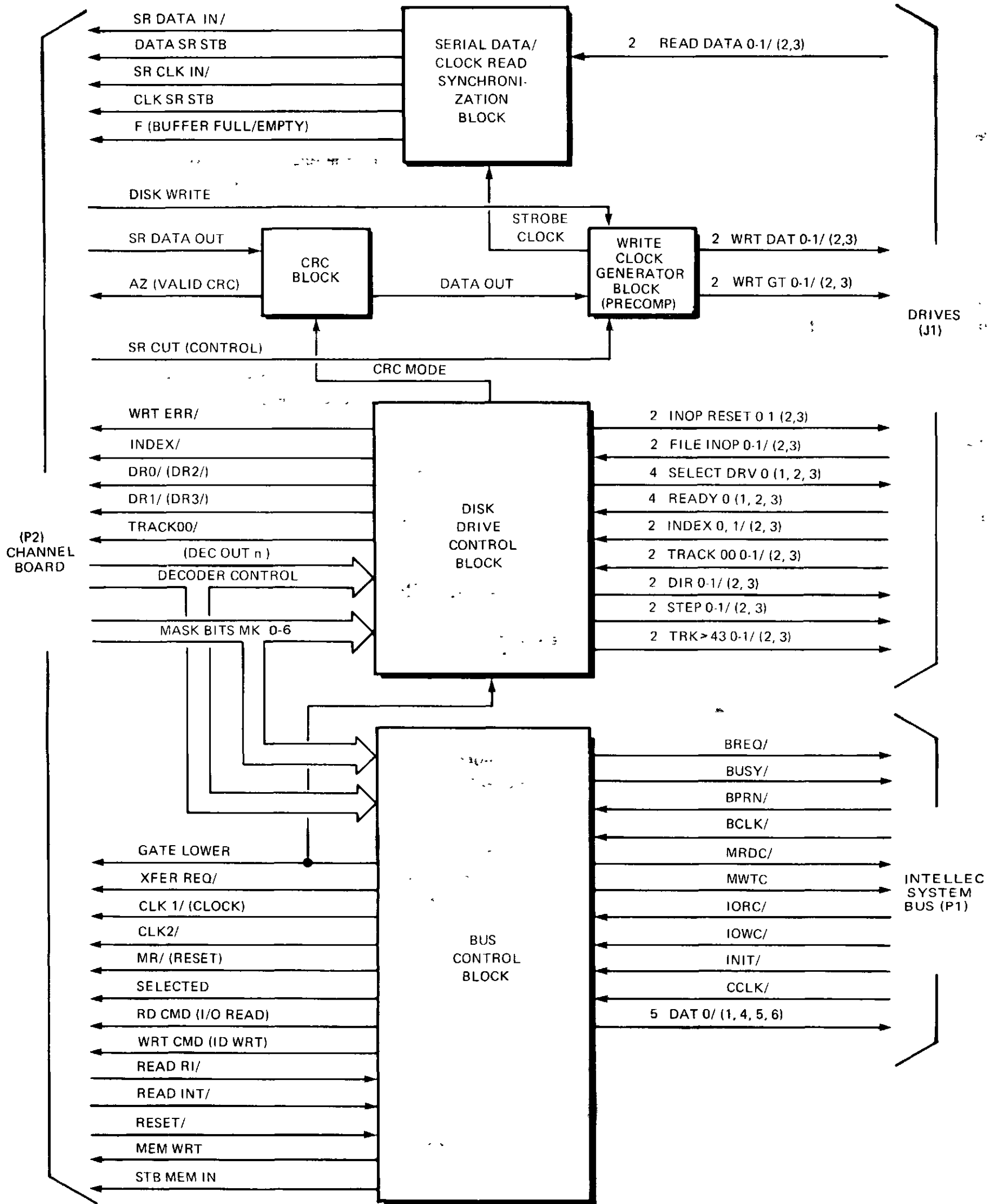

Figure 4-1 INTERFACE BOARD: FUNCTIONAL BLOCK DIAGRAM

characters for each data field (includes address mark and 128 bytes of data) read, then compares these with the two CRC characters that were appended to the data field, to verify the validity of the data.

The BUS CONTROL BLOCK provides the interface with the INTELLEC System bus. The bus control block requests and maintains master control of the system bus, and generates the memory read (MRDC/) and memory write (MWTC/) commands that allow the diskette controller to access system memory. In addition, the bus control block acknowledges (XACK/) the I/O read (IORC/) or I/O write (IOWC/) command that is issued when the CPU in the INTELLEC System executes a channel command to the diskette controller.

4.2 THEORY OF OPERATION: INTERFACE BOARD

In this section we will describe the circuitry on the Interface Board. We will divide this theory of operation discussion into five sub-sections, each dealing with one of the functional blocks defined in Section 4.1.

The Interface Board accepts/transmits signals, data and power through three different PC edge connectors:

- P1 Bus connector (to/from INTELLEC System bus)
- P2 Controller connector (to/from Channel Board)
- J1 Drive connector (to/from diskette driver)

To avoid any ambiguity when referring to connector pins in subsequent paragraphs, we will always list the connector as well as the pin whenever such references are required; for example, P1-57 refers to pin 57 on connector P1. Pin lists for the three connectors are provided in Section 4.3.

The schematic drawing (6 sheets) for the Interface Board is also provided in Section 4.3.

The circuits which drive signals to the diskette drives and those which receive signals from the drives have been specified by the drive manufacturer. Refer to Chapter 5 for more information concerning the electrical characteristics of the interface. Note that all drive output and input signals are driven and received in parallel to/from each of the attached drive boxes (drives 0, 1 and drives 2, 3). Only one drive is selected at any time however.

4.2.1 Disk Drive Control

The disk drive control block interfaces with all drive input/output signals except read data, write data and write gate. The main function of this block is to cause the read/write head on the diskette drive to move to the next track (in either direction). The circuitry in this block is shown on sheet 1 (inop reset, track > 43), sheet 3 (drive selection, drive ready and write protect), and sheet 4 (step, direction, track 0, index and file inop).

The drive READY/ lines (pins J1 - 30, J1 - 24, J1 - 26, and J1 - 22 shown on sheet 3) are driven by each drive to indicate that a diskette is ready to be accessed in that drive. The disk drive control block receives the READY/ signals (I.C. A30) which are then passed to the Channel Board via the 7400 gates (A45) and the 74367 multiplexing gates at signal lines DR0/ (pin P2 - 15) and DR1/ (pin P2 - 17). The GATE LOWER signal (A58 - 9, sheet 1) is controlled by the microprogram (see Table 3-3) to multiplex the ready signals of either drives 0 or 1 or drives 2 and 3 to these pins. The ready lines for each drive are gated by a flip-flop which retains the 'drive not ready' status for that drive (I.C.s A43 and A44). These flip-flops are cleared by the RDY RS/ pulse (A38 - 11 on sheet 4) which is generated by the microprogram (see Table 3-3). In essence these flip-flops are used to insure that the Channel Board sees a 'drive not ready' status whenever a diskette is changed on a non-selected drive. The DAT0/, DAT1/, DAT5/, and DAT6/ MDS BUS lines are driven at the P1 connector (sheet 4) whenever the READ INT/ signal is activated by the Channel Board, indicating the drive ready status to the Channel. The non-gated ready status of the selected drive is multiplexed and passed directly to the Channel Board as the SEL DR NRDY/ signal (pin P2 - 20) by the 74153 multiplexer (A31) under control of the unit select lines from the Channel Board (USA at Pin P2 - 9, USB at pin P2 - 12).

The unit select lines, USA and USB, are decoded by the 74S139 decoder (A56 on sheet 3) to generate the drive select signals. The decoder outputs are inverted and driven by 7438 gates (A17) at the DRV SEL lines to the drives (J1 - 46, J1 - 48, J1 - 50, J1 - 52). The HEAD LOAD/ signal (I.C. A46 - 4 on sheet 4) gates the DRV SEL signals. The decoder outputs are also used as inputs to the drivers for the drive select LED indicators (LED/ lines at J1 - 54, 66, 64, 68). These lines are also gated by the HEAD LOAD/ signal.

The HEAD LOAD latch is set by the LDHD/ control pulse (A47 - 3) which is generated by the microprogram being executed on the Channel Board (see Table 3-3). The LOAD latch is cleared by the UNLHD/ pulse (A47 - 11) which is also generated by the microprogram.

After loading the read/write head on the selected drive, the head must be positioned over the proper track. Any of the seven diskette operations will cause the diskette controller to seek the track specified in the I/O Parameter Block (IOPB), prior to actually performing the operation (refer to Chapter 2).

The direction of head movement is defined by the level on the DIR/ lines (pins J1 - 6, J1 - 8 on sheet 4). The DIREC control level (I.C. A58 - 11), maintained by the microprogram (see Table 3-3), is applied to the 7438 NAND gates in the disk drive control block. The outputs from these 7438 gates (A11 - 3, A11 - 6) drive the DIR/ lines.

Each pulse on the STEP/ lines (pins J1 - 2, J1 - 4) will cause the read/write head on the selected unit to move one track either in or out depending on the level of the DIR/ lines. When DIR/ is high, the head will move one track away from the center of the diskette. When DIR/ is low, the head will move one track closer to the center.

The STEP/ pulse is defined by the output of a 9602 one-shot (at A61 - 10). This one-shot is triggered by the CSTEP control pulse, generated by the microprogram (see Table 3-3), unless the read/write head at the selected unit is already over track 0 (the outermost track) while the DIR/ line indicates outward movement. If the head on the selected unit is loaded, the output from the one-shot will produce a 10 usec. pulse on the STEP/ line, as shown in Figure 4-2.

After the head has been positioned over the proper track (by pulsing STEP/ the required number of times), the diskette controller must wait at least 20 msec. before it begins examining the read data in an attempt to detect the ID address mark which precedes an address field. Reading the address field will verify that the seek operation placed the head over the proper track. Read initiate timing is illustrated in Figure 4-3.

The disk drive control block also includes a 9602 one-shot (at A61 - 7) which produces a 10 msec. TIMEOUT pulse, which is made available to the Channel Board (pin P2 - 38) for use by the microprogram. The microprogram triggers this one-shot by generating the SSCLK control pulse (see Table 3-3). Ten milliseconds after SSCLK triggers the one-shot, a low-to-high transition from the \bar{Q} output of the one-shot will appear on the TIMEOUT line.

The disk drive control block drives the INOP RESET/ lines (pins J1 - 60 and J1 - 62) and the TRACK > 43/ lines (pins J1 - 56 and J1 - 58) to the diskette drives under control of the microprogram. The TRACK > 43 latch (I.C. A46 - 7 on sheet 1) is set by the GTR43/ pulse (A59 - 3) which is generated by the microprogram (see Table 3-3).

The latch is reset by the NGTR43/ pulse (A59 - 6). The WFLRS level (I.C. A58 - 2) is maintained by the microprogram and drives the 7438 gates which in turn drive the INOP RESET/ lines to the drives. INOP RESET/ resets the FILE INOP/ lines driven by the selected drive. TRACK > 43/ forces the selected drive to reduce the write current on inner tracks of the diskette.

The disk drive control block accepts the TRACK0/, INDEX/, FILE INOP/, and WPROT/ lines from the diskette drives and passes them to the Channel Board for use by the microprogram. TRACK0/ (pin J1 - 38 or J1 - 44 depending on which drive is selected) is merely inverted twice and output as TRACK00/ at pin P2 - 11. INDEX/ (pin J1 - 42 or J1 - 40) is inverted and clocks a 7474 latch to the set state. The Q output of this latch drives the INDEX line (pin P2 - 42) to the Channel Board. The microprogram can reset the INDEX latch by generating

the RNDX/ control pulse (see Table 3-3). An INDEX/ pulse will be received once every 166.7 msec. and will be approximately 1.7 msec. wide:

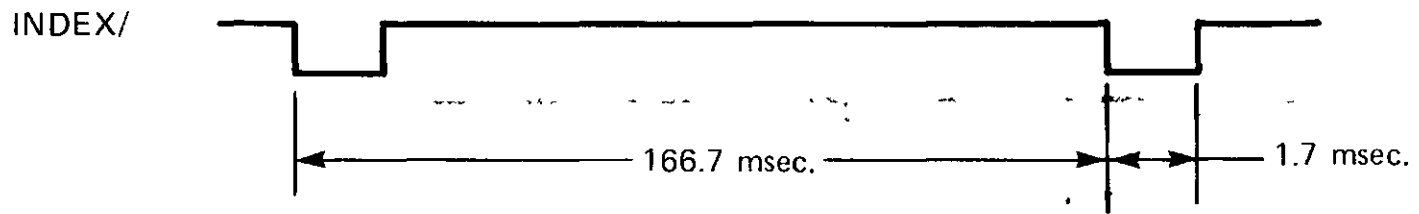

FILE INOP/ (pin J1 - 32 or J1 - 34) is inverted twice and passed to the channel board as the WRT ERR/ signal at pin P2 - 18. WPROT/ lines (pin J1 - 20 or J1 - 18) are multiplexed by the 74153 multiplexer (I.C. A31 on sheet 3) and passed on to the channel board at pin P2 - 14 to indicate the presence of a write protected diskette in the selected drive.

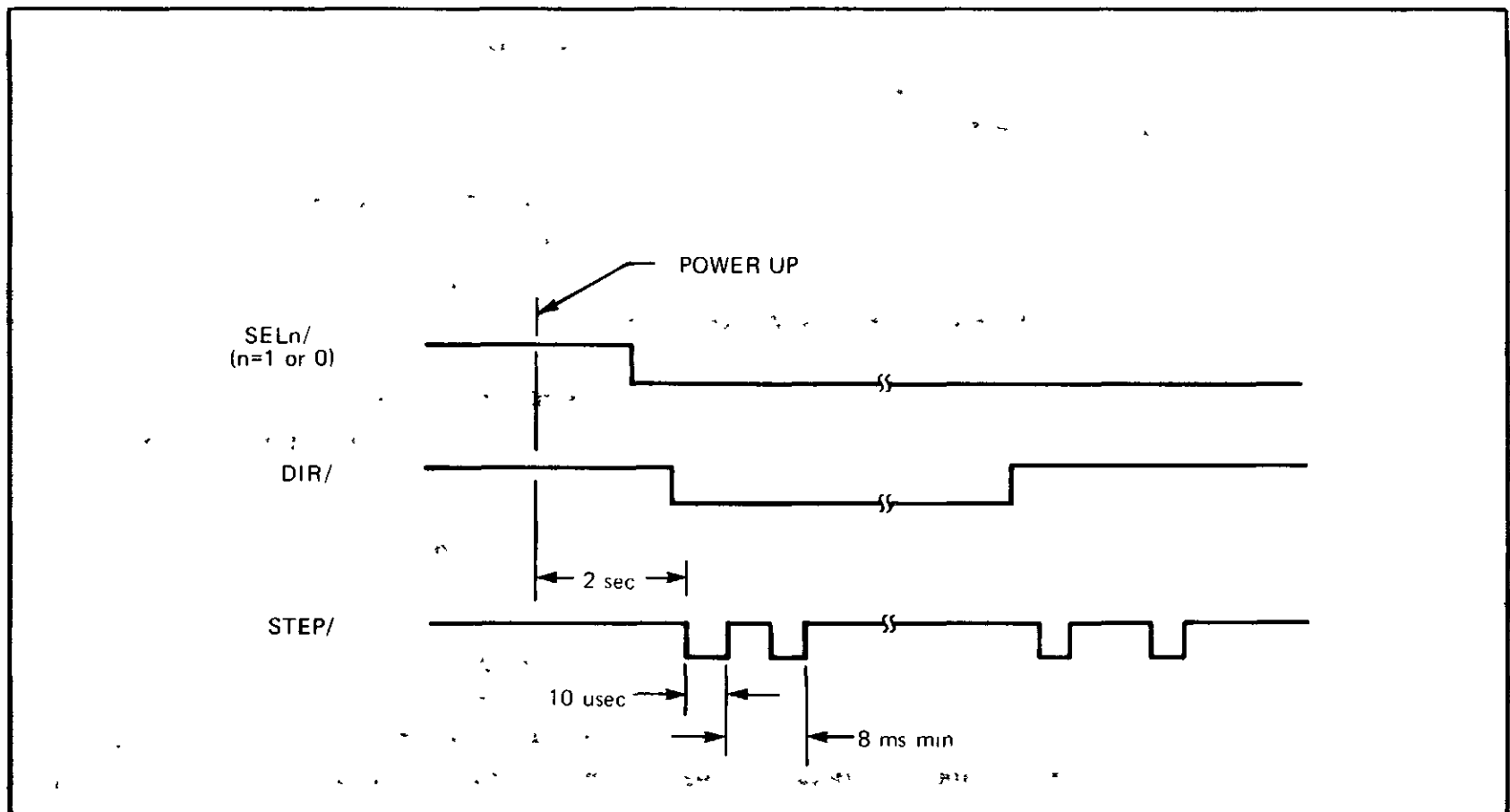

Figure 4-2 HEAD MOVEMENT CONTROL TIMING

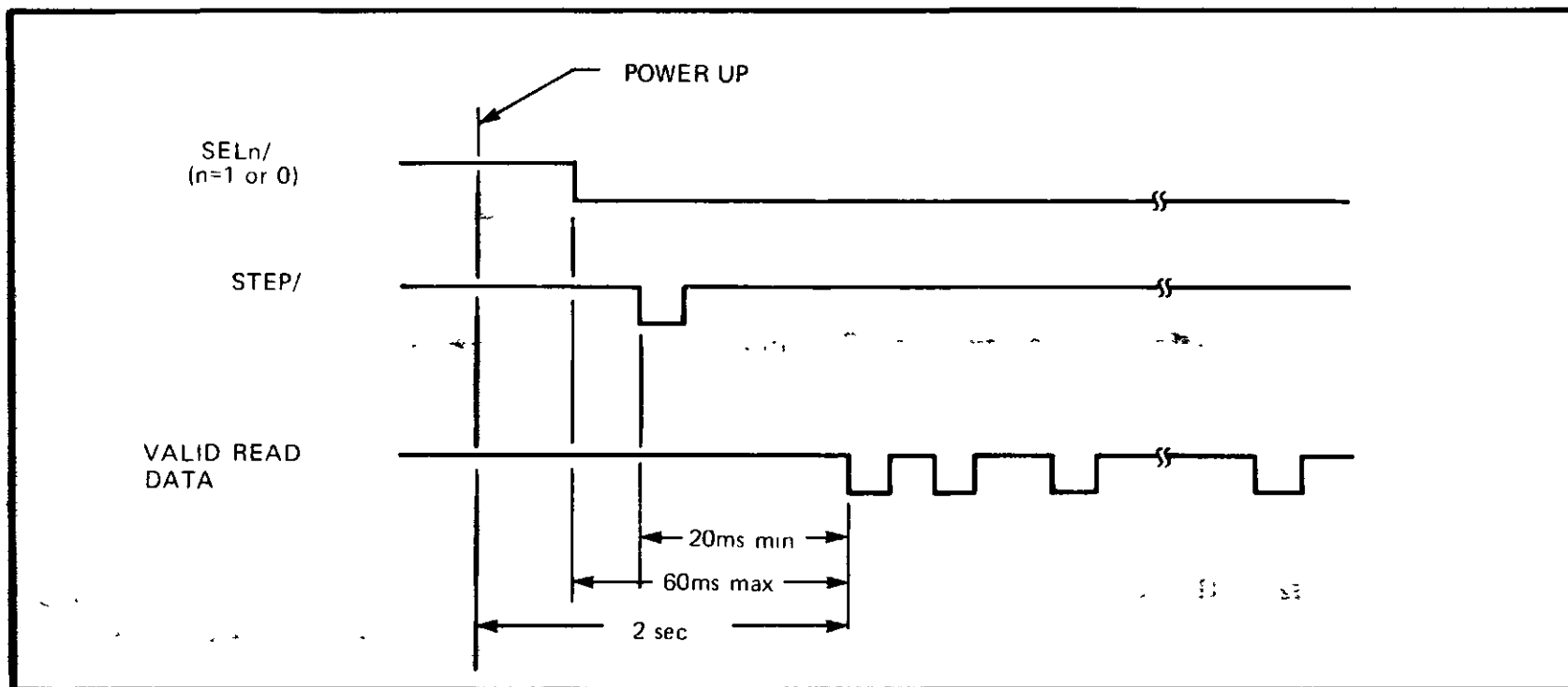

Figure 4-3 READ INITIATE TIMING

4.2.2 Write Data Generator

The write data generator block develops the pulse stream which is driven to the drives as the WRT DAT/ lines (J1 – 10 and J1 – 12 on sheet 2 of the schematic). For each negative pulse on the WRT DAT/ line, the selected drive will change the direction of write current in the magnetic head, resulting in a flux reversal on the diskette media. The selected drive supplies write current to the media (that is, 'writes') only if the WRT GT/ signal is activated. The micro-program controls the WRT GT/ lines (pins J1 – 14 and J1 – 16 on sheet 2) by the DISK WRITE signal which is sent to the Interface Board at P2 – 55 (sheet 5).

The write data is double-density encoded using the Modified-Modified Frequency Modulation (M^2FM) algorithm explained in Section 1.2. Figure 4-4 illustrates the double density encoding and provides a comparison with single-density (FM) encoding to show that the bit cell time can be halved from 4 μs to 2 μs since the minimum time between pulses is 2 μs in both cases. Note that clock bits are only written to aid read-back synchronization and data recovery.

Since the bit cell is halved with double-density encoding, data recovery is more susceptible to errors associated with magnetic bit shift. To minimize the effects of read-back bit shift, the write data block includes precompensation circuitry. This circuitry anticipates magnetic shifts by writing bits earlier or later than nominal bit times in an opposite direction to the magnetic shifts that will occur upon readback. For example, the third data bit from the left (M^2FM) in Figure 4-4 will tend to shift upon readback towards the '0' bit cell (to the right). This shift is 'precompensated' by writing the bit closer to the preceding data bit (more to the left).

The precompensation and encoding circuitry are shown on sheet 2 and 3 of the schematic. The write oscillator, Y1, outputs an 8 MHz clock signal which drives a 74164 (A8 – 8) 8-bit shift register which has been connected as a bit-ring. The outputs of the bit ring are connected to 'AND' gates (7402, 7411 and 7408) which generate active high pulses relating to the specific clock bit times and data bit times which, in turn, are selected as WRT DAT/ pulses by the 74150 multiplexer (A34).

Figure 4-5 illustrates the timing of the precompensation circuitry which generates the pulses used by the encoding circuitry. Note that there are two possible times to write a clock bit: on-time (C), or 125 ns. early (CE). There are three possible times to write a data bit: on-time (D), 250 ns. early (DE) or 250 ns. late (DL).

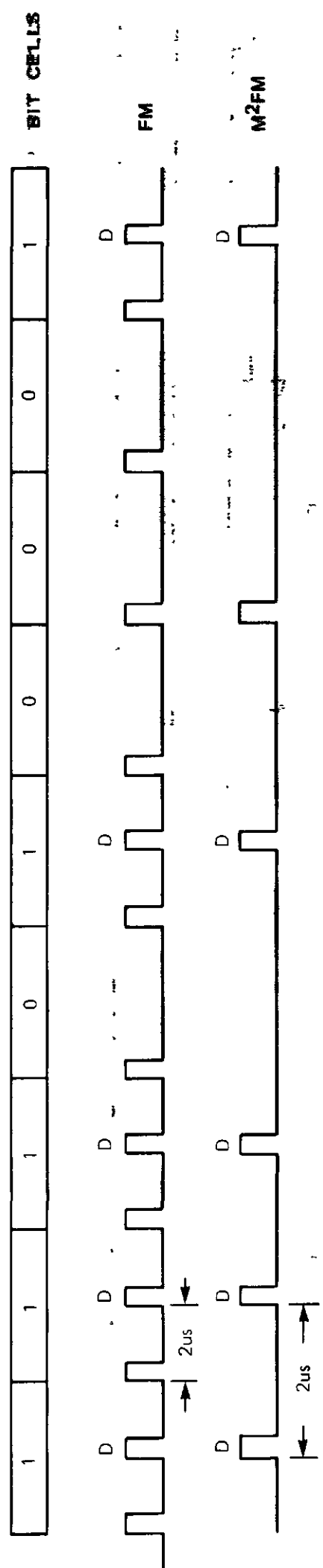

M2FM ENCODING RULES:

- WRITE CLOCK BITS (PULSES) AT THE BEGINNING OF A BIT CELL
- WRITE DATA BITS AT THE MIDDLE OF A BIT CELL
- WRITE A DATA BIT FOR EACH BIT CELL WITH A BINARY '1' VALUE
- WRITE A CLOCK BIT ONLY IF THERE IS NO DATA BIT IN THE CURRENT CELL AND THERE WAS NO CLOCK OR DATA BIT IN THE PRECEDING CELL

Figure 4-4 M2FM DATA ENCODING

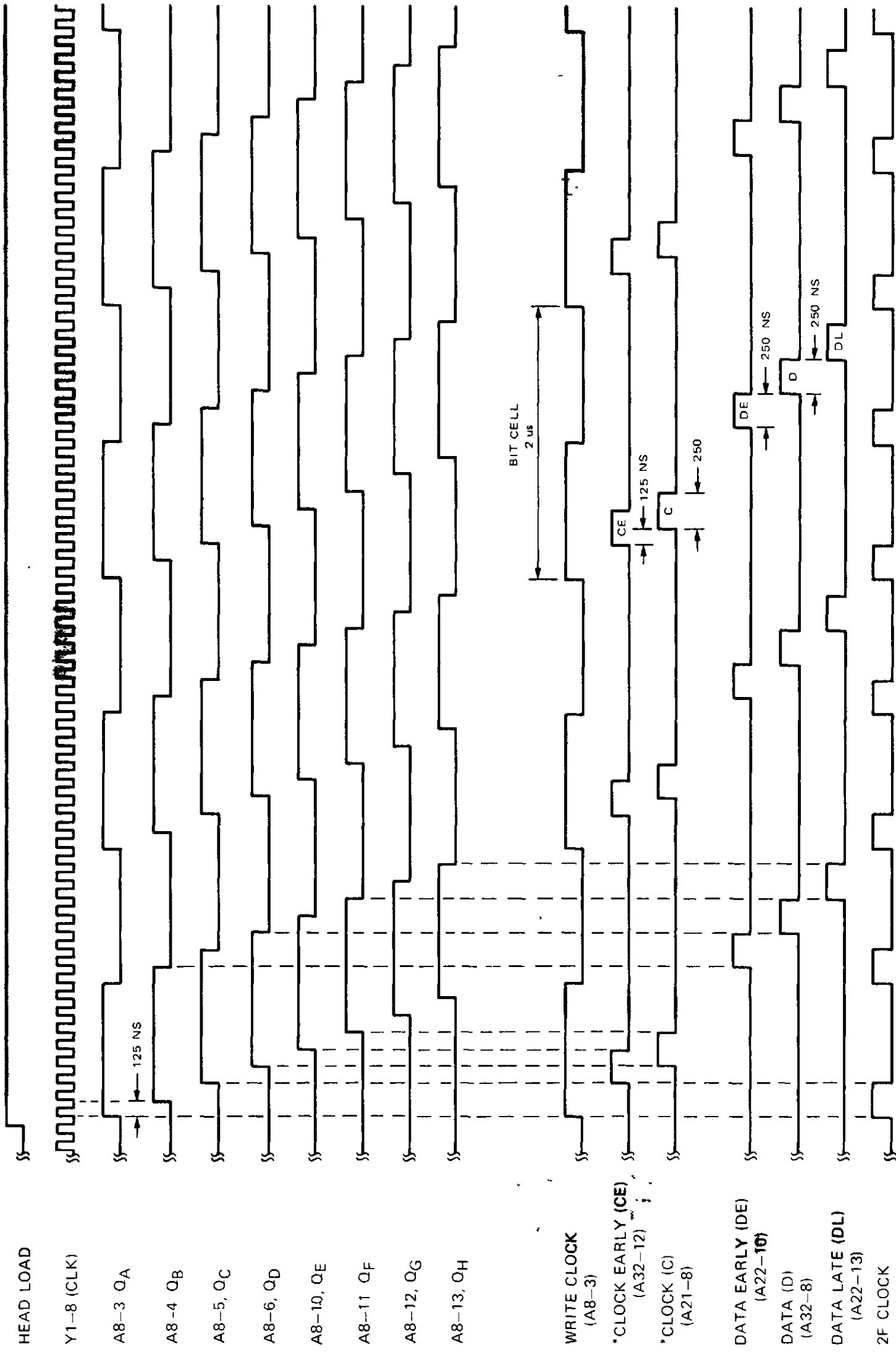

NOTE

*CLOCK AND CLOCK EARLY ARE GATED DURING DISK WRITE TIME BY A LATCH TO PROVIDE '1F' CLOCKS FOR M₂FM IN THIS DIAGRAM, ASSUME THE GATE SIGNAL IS ALWAYS ACTIVE, FOR TIMING ILLUSTRATION PURPOSES

THIS DIAGRAM ILLUSTRATES THE GENERATION OF WRITE DATA PULSE TIMING, AND NOT THE ACTUAL 'WRITE DATA' ITSELF. SEE FIGURE 4-6 ENTITLED 'DOUBLE-DENSITY WRITE DATA TIMING'.

Figure 4-5 PRECOMPENSATION TIMING

The WRITE CLOCK signal (A8 – 3) is used to shift the serial data in the precomp selection and encoding shift register (A48 on sheet 3). In addition, the WRITE CLOCK signal is multiplexed with the read clock by the DISK WRITE signal to generate the CLOCK SR STB and DATA SR STB signals (P2 – 8 and P2 – 48 shown on sheet 5). These signals are used by the Channel Board to shift the data byte being written or read by the drive.

The encoding and precompensation selection for the write data is performed by the data shift register (A48) and the 74150 multiplexer (A34). The outputs of the register (SDA, SDB, SDC, SDD) drive the select inputs of the 74150 multiplexer. Depending upon the data pattern presented at the select inputs, the 74150 selects one of the five timing pulses during each bit cell (i.e., C, CE, D, DE or DL). For a 'zero-data' bit cell which was preceded by a bit cell which generated a pulse, no pulse is selected. The pair of flip-flops (A10 on sheet 3) which are clocked by WRITE CLOCK generate the CLOCK GATE signal (A10 – 8). This signal gates the C and CE pulses so that only every other clock bit is written in a string of 'zero' bit cells. Figure 4-6 illustrates the signal timing of the circuitry which generates WRT DAT/ pulses.

The AMWRT/ latch (A58 – 6 on sheet 1) is controlled by the microprogram on the Channel Board and is used to set the CLOCK GATE active during the writing of an address mark, resulting in a unique clock pattern (three clock bits in sequential bit cells) which aids in read-back synchronization. In addition, the AMWRT/ level controls the 74157 multiplexer (A7 – 5 on sheet 2) by selecting the appropriate precompensation times during an address mark. Note that all of the switches shown on sheet 2 and 3 of the schematic are only manufacturing options for an alternate type of data encoding and are not field selectable.

4.2.3 Serial Data/Clock Synchronization

The serial data/clock synchronization block contains circuitry which separates the serial READ DATA pulses from the drive into data and clock bits for serial transfer to the Channel Board. The circuitry can be subdivided into the following segments: phase locked oscillator (PLO, shown on sheet 6), PLO start-up logic (sheet 5), and byte-synchronization counter (A19 on sheet 4).

The PLO consists of linear circuitry which 'locks' onto the recorded information and generates separate 'windows' for data bits and clock bits. Staying in synchronization with small, slow variations in disk speed, it averages quick variations caused by bit shift. Figure 4-7 provides a block diagram of the PLO with startup logic and data separator.

When not reading, the RESET READ/ level (A46 – 9 on sheet 4), maintained by the microprogram on the Channel Board, is active (low) and the PLO is locked to the write oscillator. The 2F CLOCK signal is multiplexed to fire the SAMPLE one-shot (A37 – 5 on sheet 5) which provides the input pulse train feeding the PLO. When the microprogram initiates a read operation by inactivating the RESET READ/ signal, the PLO startup logic is activated. The startup logic monitors the drives' READ DATA/ signals (pins J1 – 36 and J1 – 28) until the all 1's area in an address mark preamble is detected. Then the PLO input pulse stream is switched from the write oscillator to read data. As soon as the PLO is locked to the read data, the startup logic starts waiting for the first bit of the address mark, that is, the first '0' bit cell. When this bit cell is detected, the ENABLE BR signal (A15 – 5 on sheet 5) is activated, enabling the 74195 bit ring to start counting the bits. On every eighth bit cell count, the 'F' signal (pin P2 – 58) is activated to notify the Channel Board that a valid data byte has been read. When the Channel Board receives the first 'F' signal, it compares the data and clock bytes with the known address mark patterns. If there is a match, the Channel Board continues to accept data bytes and the PLO stays locked to the read data. If there is not a match, the Channel Board resets the read circuitry by activating the RESET READ/ level and later enabling the read circuitry to continue searching for the desired address mark. Figure 4-8 illustrates the detailed timing for the serial data/clock synchronization block during the address mark synchronization process.

4.2.4 Cyclic Redundancy Check (CRC)

Two cyclic redundancy check (CRC) characters (16-bits) are generated for each data field (i.e., the address mark and 128 bytes of data) and are then appended to the data field as it is written to diskette. During all read operations, 16 CRC bits are generated as data is read; these CRC bits are then compared with the CRC bits that were appended to the field when it was written. CRC generation and checking are performed by the CRC block which consists of

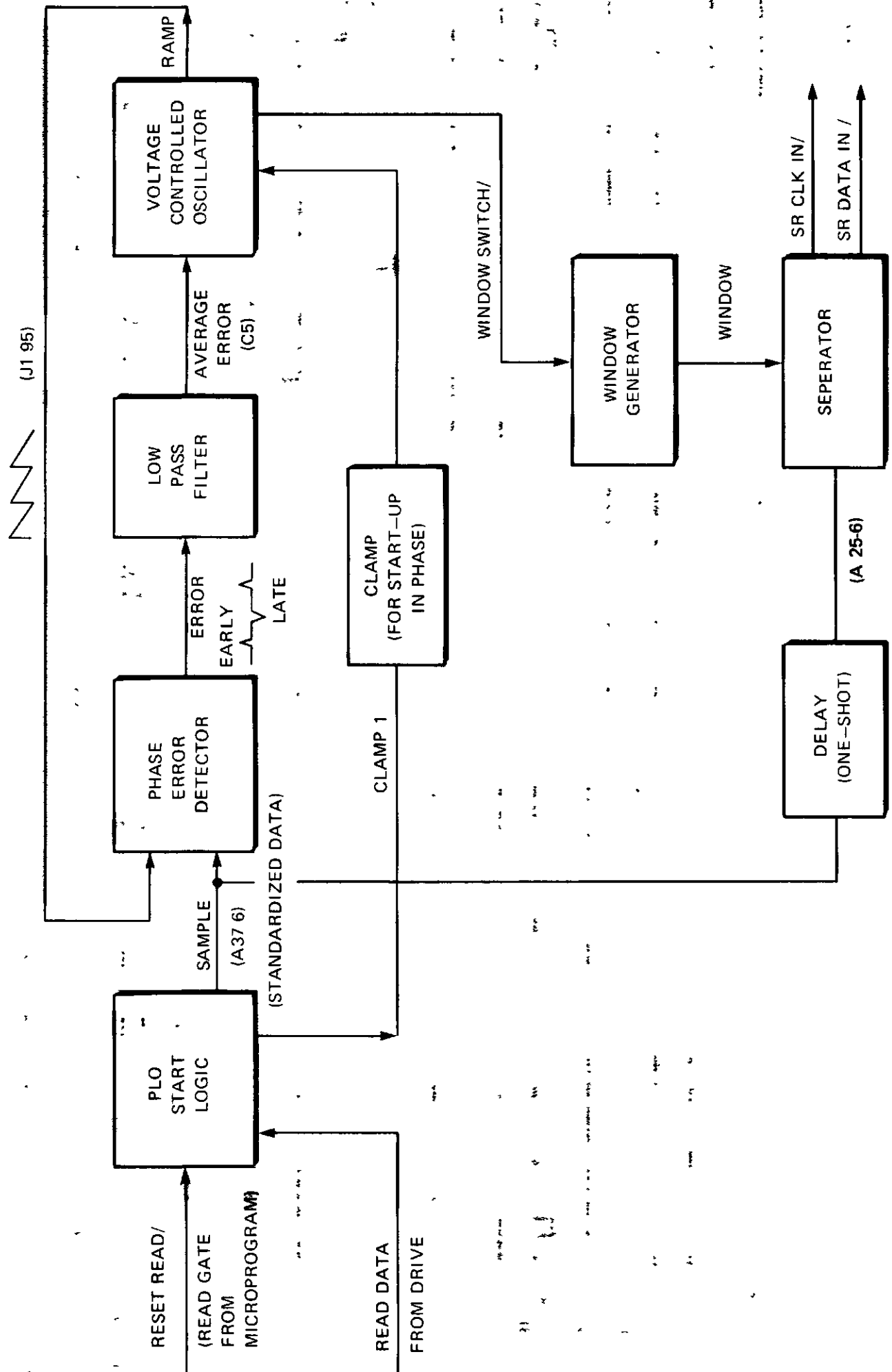

Figure 4-7 PHASE LOCKED OSCILLATOR

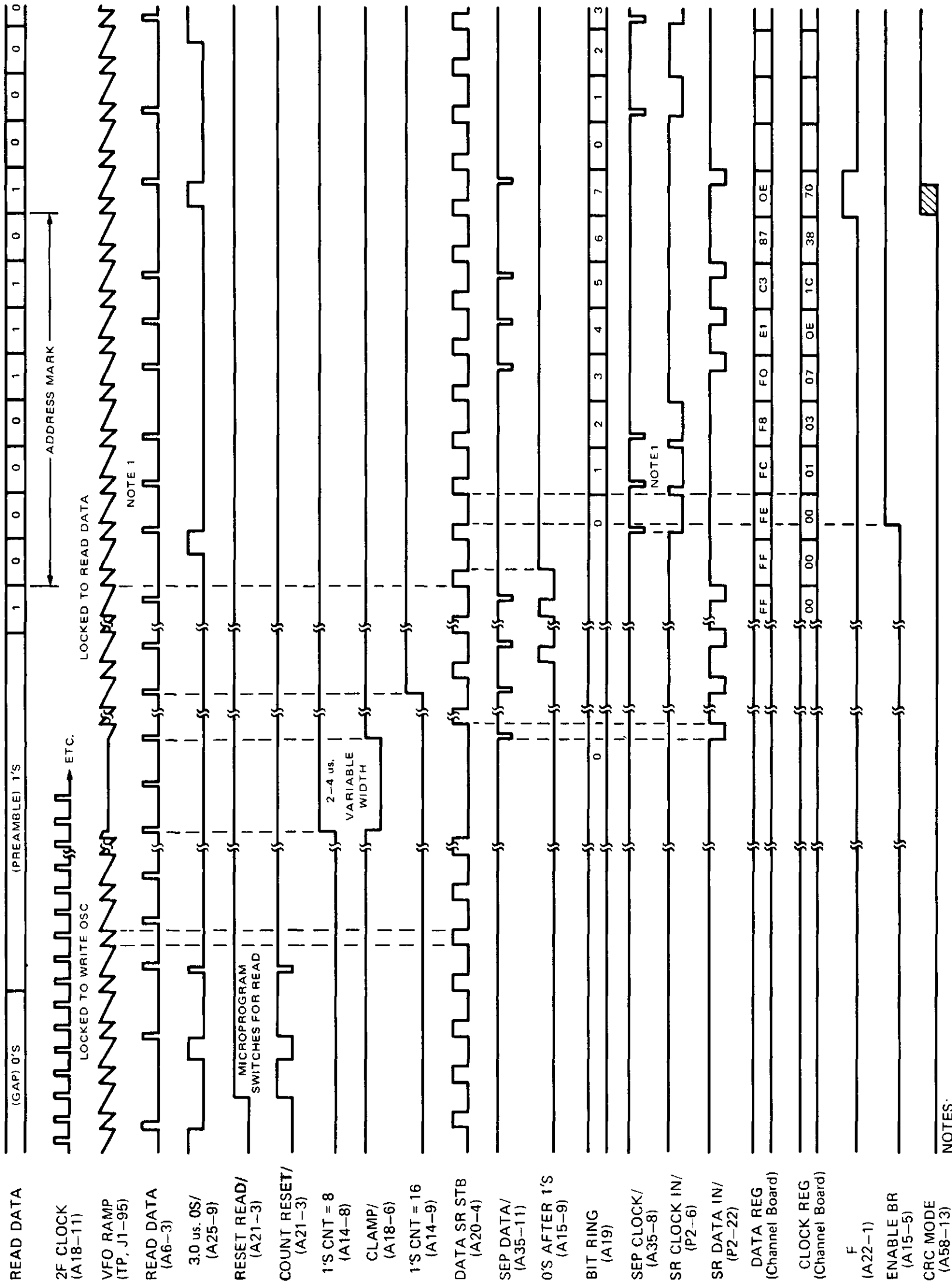

Figure 4-8 READ SYNCHRONIZATION TIMING

a 9401 Universal Polynomial Generator (UPG), a 7451 multiplexer, a control latch, and several inverting circuits, as shown on sheet 4 of the board schematic (see Section 4.3).

During write operations, data bits from the data shift register (on the Channel Board — see Section 3.2.5) are input to the 9401 UPG device (pin 11, D), as well as the 7451 multiplexer via the SR DATA OUT line. The SR OUT control level (maintained by the microprogram on the Channel Board — see Table 3-3) allows the data bits through the multiplexer and onto the WRT DAT/ line. The data bits, which are also being input to the 9401 device, cause the 9401 to generate the CRC characters (16 bits) for the 128 data bytes by 'dividing' the data by the encoding polynomial ($x^{16} + x^{12} + x^5 + 1$). When the entire 129 bytes (1 address mark byte and 128 data bytes) have been written to disk, the microprogram lowers the SR OUT level, which allows the 16 CRC bits being output by the 9401 device (pin 12, SDO) to pass through the 7451 multiplexer and be written onto the diskette immediately after the data.

During read operations, each data byte is shifted into the 9401 UPG device as the succeeding data byte is being shifted into the data shift register (on the Channel Board). The data bits are carried on the SR DATA OUT line, just as during a write operation. The absence of the SR OUT control level (from the microprogram), however, prevents the data bits from being gated out onto the WRT DAT/ line. The 129 bytes are 'divided' by the encoding polynomial to generate 16 CRC bits. After all 129 bytes have been read, the 16 CRC bits which were appended to the data when it was written are also shifted into the 9401 device where they are compared with the CRC bits just generated. If the two sets of CRC bits match, the all zeroes output (ER, pin 13) goes true (low), and is applied to the D-input on a 7474 latch at A60 — 12. When the bit counter in address mark detection logic determines that all data has been shifted out of the data register (i.e., when the F signal goes true), the low level from the ER output is clocked into the 7474 latch. The high \bar{Q} output from this latch drives the AZ line (pin P2 — 41) to the Channel Board.

The microprogram controls the various operating modes of the 9401 UPG by maintaining the appropriate levels on the CRCMD control line (see Table 3-3). CRCMD, which feeds the shift right (CWE) input to the UPG, is usually low, causing logical zeroes to be shifted through the UPG. It is only when CRC characters are being generated or checked that CRCMD presents a false (high) level to the active-low CWE input. The 9401 device is clocked by the data shift register strobe signal.

4.2.5 Bus Control

The bus control block maintains the diskette controller interface with the INTELLEC System bus. This block consists of a 52-104 Bus Control I.C., six flip-flops, a 9602 one-shot multivibrator and assorted gating and inverting circuits, as shown on sheets 1 and 2 of the board schematic (see Section 4.3).

Before the diskette controller can transfer data to or from system memory, the bus control block must request and be granted master control of the INTELLEC System bus. When the Diskette Channel requires access to memory, the microprogram (being executed on the Channel Board — see Chapter 3) will initiate the bus request sequence by generating the SMREQ/ control pulse (see Table 3-3). SMREQ/ will cause the 74LS112 latch at A51 — 4 to be pre-set unless the inhibit memory write latch (A46 — 13) is set.

The inhibit memory write latch will be set during VERIFY CRC diskette operations, in which data is read and verified but is not transferred to memory. The inhibit memory write latch is set and reset by the SINH/ and RINH/ control pulses, respectively (both are generated by the microprogram, see Table 3-3).

The Q output from the 7474 latch which is pre-set by SMREQ/ (A51 — 5) is applied to the transfer request inputs of the 52-104 Bus Control I.C. (A50 — 25, 3, 4). The next bus clock pulse (BCLK/ at P1 — 13) will clock this input into the 52-104. The low \bar{Q} output drives the XFER REQ/ line (pin P2 — 39) which informs the Channel Board that the memory transfer is not yet complete. The Q output from the transfer request latch feeds the J-input of the data overrun (DOR/) latch.

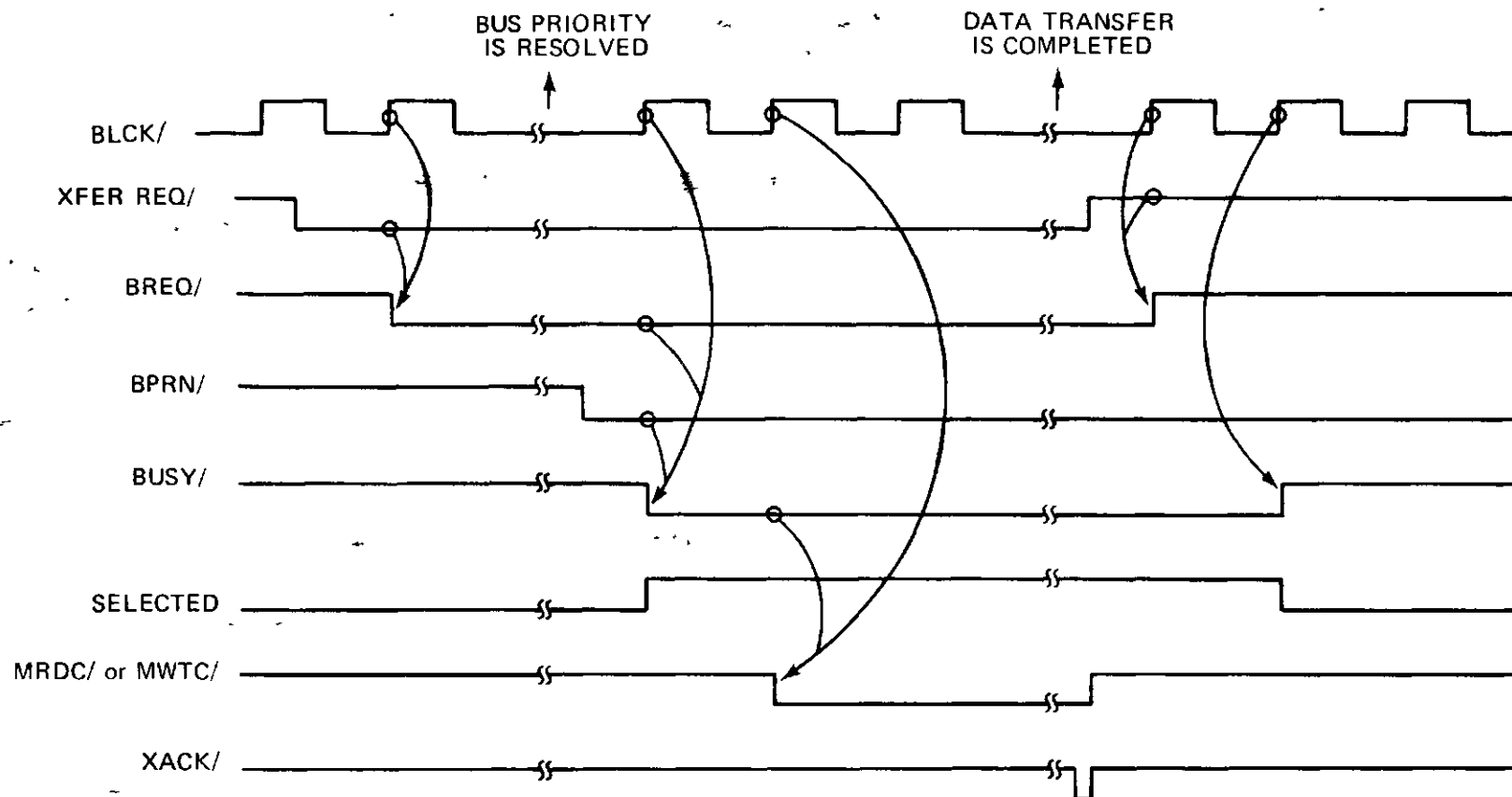

Figure 4-9 BUS CONTROL TIMING

If the microprogram requests a memory access again (i.e., if SMREQ is generated again) before the current access is completed, the data overrun latch will be clocked to the set state, and its \bar{Q} output will drive a true (low) level on the DOR/ error line to the Channel Board (pin P2 - 16).

When the 52-104 Bus Control I.C. receives the XFER REQ input, it initiates a memory transfer bus cycle, causing BREQ/ (pin P1 - 18) to go true (low). BREQ/ requests use of the INTELLEC System bus.

If no other master module is using the bus (i.e., if BUSY/ is false), and if no higher priority module is requesting the bus (i.e., the bus priority in line, BPRN/, is true), the next bus clock pulse (BCLK/) after BREQ/ will cause the 52-104 to activate BUSY/ (pin P1 - 17). BUSY/ informs the INTELLEC System that the diskette controller has master control of the bus. In addition the 52-104 activates the ADEN/ output which is inverted to generate the SELECTED signal (pin P2 - 43). On the next BCLK/ pulse after BUSY/ goes true, the 52-104 will drive the memory read (MRDC/) or memory write (MWTC/) command at pins P1 - 19 and P1 - 20, respectively, depending upon whether a read or write cycle was requested by the microprogram controlled MEMWRT level (A58 - 4 on sheet 1).

Recall that while logic on the Interface Board requests control of the bus, then generates the memory read or write command, it is the Channel Board which actually drives the system data and address buses (refer to Chapter 3) as gated by the SELECTED signal.

When the memory has accepted the data to be written or output the data which was read, it generates a transfer acknowledge signal (XACK/) which is received at pin P1 - 23 on the Interface Board. XACK/ triggers a 9602 one-shot (A37 - 11). The high pulse (~ 70 nsec. wide) at the Q output of the one-shot drives the STB MEM IN line (pin P2 - 29) which allows the Channel Board to accept data read from memory.

The \bar{Q} output from the one-shot clocks the XFER REQ 7474 latch at A51 - 1 to the reset state. As a result, succeeding bus clock pulses (BCLK/) can reset the bus control logic, and cause the Interface Board to relinquish master bus control to another module.

Bus control timing is illustrated in Figure 4-9.

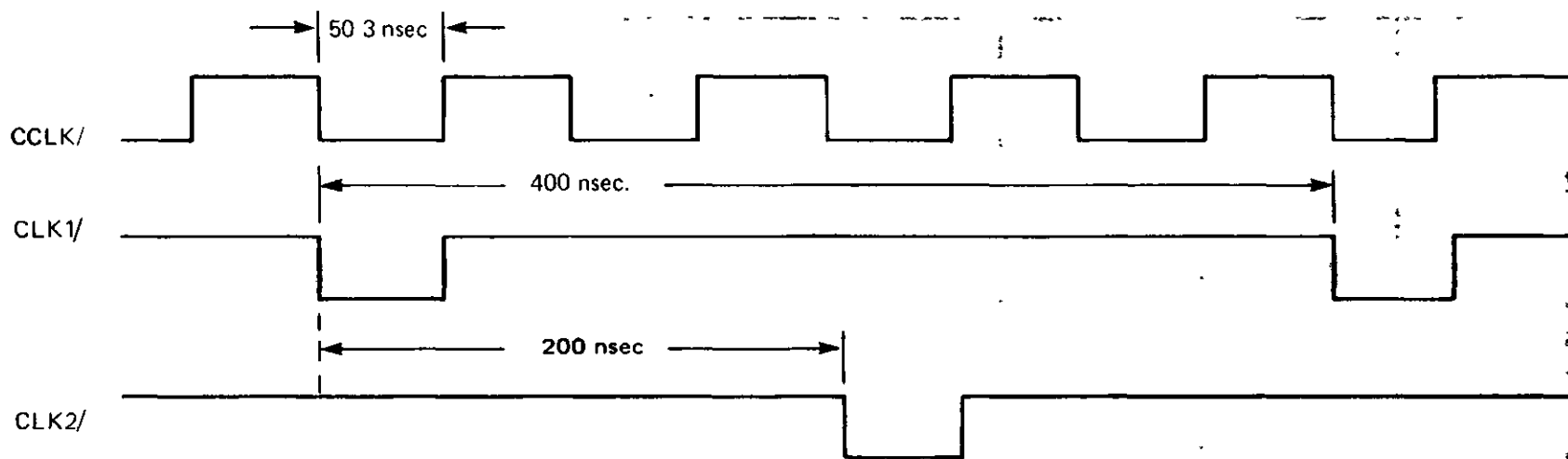

Figure 4-10 CLK1/ AND CLK2/ TIMING

In addition to being the master module during memory access operations, the diskette controller also acts as the 'slave' module during I/O operations in which the CPU executes a channel command for the diskette controller. The bus control block accepts the I/O read (IORC/) or I/O write (IOWC/) command from the CPU (at pins P1 - 21, P1 - 22), inverts it and passes it to the Channel Board on the READ CMD line (pin P2 - 60) or the WRT CMD line (pin P2 - 53).

The 'slave' module must acknowledge all commands from the master. The bus control block performs this function in response to channel commands. Receipt of a 'reset', 'read subsystem status' or 'read result type' channel command (see Chapter 2) will clock the acknowledge latch (at A39 - 3) to the set state. The acknowledge latch is set at the proper time by the SACK/ control pulse (A57 - 11) from the microprogram for each of the other channel commands. The \bar{Q} output from the acknowledge latch feeds a 74125 tri-state driver. The output from the 74125 circuit (XACK/) is driven through pin P1 - 23. XACK/ is reset when IORC/ or IOWC/ go false via the 7432 gate (A38 - 8).

The bus control block also has an 8 position rotary switch which connects the interrupt line (INT/) from the Channel Board (pin P2 - 40) with one of the eight system priority interrupt request lines, INT0/ - INT7/ (via a 74125 tri-state gate which provides the required electrical characteristics for the INTELLEC System bus).

In addition, the two phase clock pulses (CLK1/ and CLK2/ on sheet 1) are generated in the bus control block. CLK1/ and CLK2/ are derived from the INTELLEC common clock, CCLK/ (9.8 MHz). CCLK/ is divided by the two 74LS74 flip-flops at A54 to produce CLK1/ and CLK2/ (400 nsec. period, 12% duty cycle) at the outputs of the 74S139 decoder as shown in Figure 4-10.

4.3 SCHEMATICS/PIN LISTS: INTERFACE BOARD

The schematic drawing (6 sheets) for the Interface Board is provided in Figure 4-11. These schematics are subject to change without notice. The Reference Schematic Drawings shipped with the Diskette System should be used as a reference.

Table 4-1 lists the pins and designated signal functions for the 86-pin P1 bus connector. Table 4-2 lists the same information for the 60-pin P2 controller connector, while Table 4-3 provides this information for the 100-pin J1 drive connector.

Table 4-1 PIN LIST: P1 BUS CONNECTOR



PIN	SIGNAL	FUNCTION
1 2 3 4 5 6 7 8 9 10 11 12	 NO CONNECTION	
13 14 15 16 17 18 19 20 21 22 23	BCLK/ INIT/ BPRN/ BPRO/ BUSY/ BREQ/ MRDC/ MWTC/ IORC/ IOWC/ XACK/	Bus clock (9.803 MHz) System initialization Bus priority in Bus priority out Bus busy Bus request Memory read command Memory write command I/O read command I/O write command Transfer acknowledge
24 25 26 27 28 29 30	 NO CONNECTION	
31	CCLK/	Common clock (9.803 MHz)
32 33 34	 NO CONNECTION	
35 36 37 38 39 40 41 42	INT6/ INT7/ INT4/ INT5/ INT2/ INT3/ INT0/ INT1/	Priority interrupt request lines
43 44 45 46 47 48	 NO CONNECTION	

Table 4-1 PIN LIST: P1 BUS CONNECTOR (CONTINUED)

PIN	SIGNAL		FUNCTION
49	↑ NO CONNECTION ↓		
50			
51			
52			
53			
54			
55			
56			
57			
58			
59			
60			
61			
62			
63			
64			
65			
66			
67			
68			
69			
70			
71			
72			
73			
74			
75			
76			
77			
78			
79			
80			
81			
82			
83			
84			
85			
86			

Table 4-2 PIN LIST: P2 CONTROLLER CONNECTOR

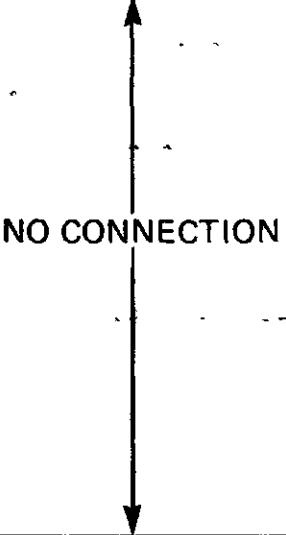
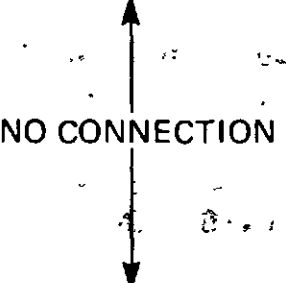
PIN	SIGNAL	FUNCTION
1	—	—
2	MK4	Mask bit 4
3	CLK1/	Diskette controller clock 1
4	MK1	Mask bit 1
5	TP	Test point
6	SR CLK IN/	Serial clock in line
7	TP	Test point
8	CLK SR STB	Serial clock strobe
9	USA	Unit select bit A
10	—	—
11	TRACK00/	Track 00 detected
12	USB	Unit select bit B
13	MK0	Mask bit 0
14	DISK WPROT/	Disk write protected
15	DR0/ (DR2/)	Drive 0 ready or Drive 2 ready
16	DOR/	Data overrun error
17	DR1/ (DR3/)	Drive 1 ready or drive 3 ready
18	WRT ERR/	Write error
19	SR OUT	Shift register out control level
20	SEL DR NRDY/	Selected drive not ready
21	DEC OUT 0/	Control decoder output 0
22	SR DATA IN/	Serial data in line
23	—	—
24	DATA SR STB/	Serial data strobe
25	SR DATA OUT	Serial data out line
26	—	—
27	DEC OUT 5/	Control decoder 5 output
28	DEC OUT 4/	Control decoder 4 output
29	STB MEM IN	Strobe memory data in
30	CLK2/	Diskette controller clock 2
31	—	—
32	—	—
33	DEC OUT 7	Control decoder output 7
34	MK3	Mask bit 3
35	DEC OUT 6	Control decoder output 6
36	MK6	Mask bit 6
37	RD RI/	'Read result type' channel command
38	TIME OUT	10 msec. timing pulse
39	XFER REQ/	Controller requests INTELLEC System bus
40	INT/	Interrupt line
41	AZ	All zeros, valid CRC check
42	INDEX	Index mark detected
43	SELECTED	Controller has control of INTELLEC System bus
44	GATE LOWER	Input low order data byte
45	—	—
46	MR/	Master reset
47	—	—
48	—	—

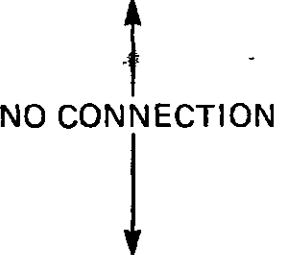
Table 4-2 PIN LIST: P2 CONTROLLER CONNECTOR (CONTINUED)

PIN	SIGNAL	FUNCTION
49	RESET/	'Reset' channel command
50	MK2	Mask bit 2
51	MEM WRT	Write data to Intellec System memory
52	DEC OUT 1/	Control decoder output 1
53	WRT CMD	I/O write command
54	MK5	Mask bit 5
55	WRTGT	Write gate control level
56	MR	Master reset
57	RD INT/	'Read subsystem status' channel command
58	F	Shift registers full or empty
59	TP	Test point
60	RD CMD	I/O read command

Table 4-3 J1 DRIVE CONNECTOR

PIN	SIGNAL	FUNCTION
1	GND	Ground
2	STEP 0, 1/	Steps head one track (drive 0, 1)
3	GND	Ground
4	STEP 2, 3/	Steps head one track (drive 2, 3)
5	GND	Ground
6	DIR 0, 1/	Step direction indicator (drive 0, 1)
7	GND	Ground
8	DIR 2, 3/	Step direction indicator (drive 2, 3)
9	GND	Ground
10	WRT DAT 0, 1/	Write data (drive 0, 1)
11	GND	Ground
12	WRT DAT 2, 3/	Write data (drive 2, 3)
13	GND	Ground
14	WRT GT 0, 1/	Write gate (drive 0, 1)
15	GND	Ground
16	WRT GT 2, 3/	Write gate (drive 2, 3)
17	GND	Ground
18	WPROT 2, 3/	Diskette write protected indicator (drive 0, 1)
19	GND	Ground
20	WPROT 0, 1/	Diskette write protected indicator (drive 2, 3)
21	GND	Ground
22	READY 3/	Ready indicator from drive 3
23	GND	Ground
24	READY 1/	Ready indicator from drive 1
25	GND	Ground
26	READY 2/	Ready indicator from drive 2
27	GND	Ground
28	READ DATA 2, 3/	Read data, unseparated (drive 2, 3)

Table 4-3 J1 DRIVE CONNECTOR (CONTINUED)

PIN	SIGNAL	FUNCTION
29	GND	Ground
30	READY 0/	Ready indicator from drive 0
31	GND	Ground
32	FILE INOP 0, 1/	Drive inoperable, write fault (drive 0, 1)
33	GND	Ground
34	FILE INOP 2, 3/	Drive inoperable, write fault (drive 2, 3)
35	GND	Ground
36	READ DATA 0, 1/	Read data, unseparated (drive 0, 1)
37	GND	Ground
38	TRACK00 - 0, 1/	Track 0 indicator (drive 0, 1)
39	GND	Ground
40	INDEX 2, 3/	Index indicator (drive 2, 3)
41	GND	Ground
42	INDEX 0, 1/	Index indicator (drive 0, 1)
43	GND	Ground
44	TRACK00 - 2, 3/	Track 0 indicator (drive 2, 3)
45	GND	Ground
46	DRV SEL 0/	Select/load head drive 0
47	GND	Ground
48	DRV SEL 1/	Select/load head drive 1
49	GND	Ground
50	DRV SEL 2/	Select/load head drive 2
51	GND	Ground
52	DRV SEL 3/	Select/load head drive 3
53	GND	Ground
54	LED 0/	Drive 0 selected indicator
55	GND	Ground
56	TRACK > 43 - 0, 1/	Track greater than 43, low write current (drive 0, 1)
57	GND	Ground
58	TRACK > 43 - 2, 3/	Track greater than 43, low write current (drive 2, 3)
59	GND	Ground
60	INOP RESET 0, 1/	File inoperable reset (drive 0, 1)
61	GND	Ground
62	INOP RESET 2, 3/	File inoperable reset (drive 2, 3)
63	GND	Ground
64	LED 2/	Drive 2 selected indicator
65	GND	Ground
66	LED 1/	Drive 1 selected indicator
67	GND	Ground
68	LED 3/	Drive 3 selected indicator
69	TP	Test Point
70	TP	
71	TP	
72	TP	
73	TP	
74	TP	
75	TP	
76	TP	

Table 4-3 J1 DRIVE CONNECTOR (CONTINUED)

PIN	SIGNAL	FUNCTION
77	TP	
78	TP	
79	TP	
80	TP	
81	TP	
82	TP	
83	TP	
84	TP	
85	TP	
86	TP	
87	TP	
88	TP	
89	TP	
90	TP	
91	TP	
92	TP	
93	TP	
94	TP	
95	TP	
96	TP	
97	TP	
98	TP	
99	TP	
100	TP	

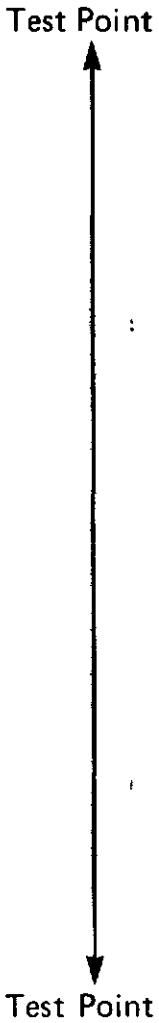
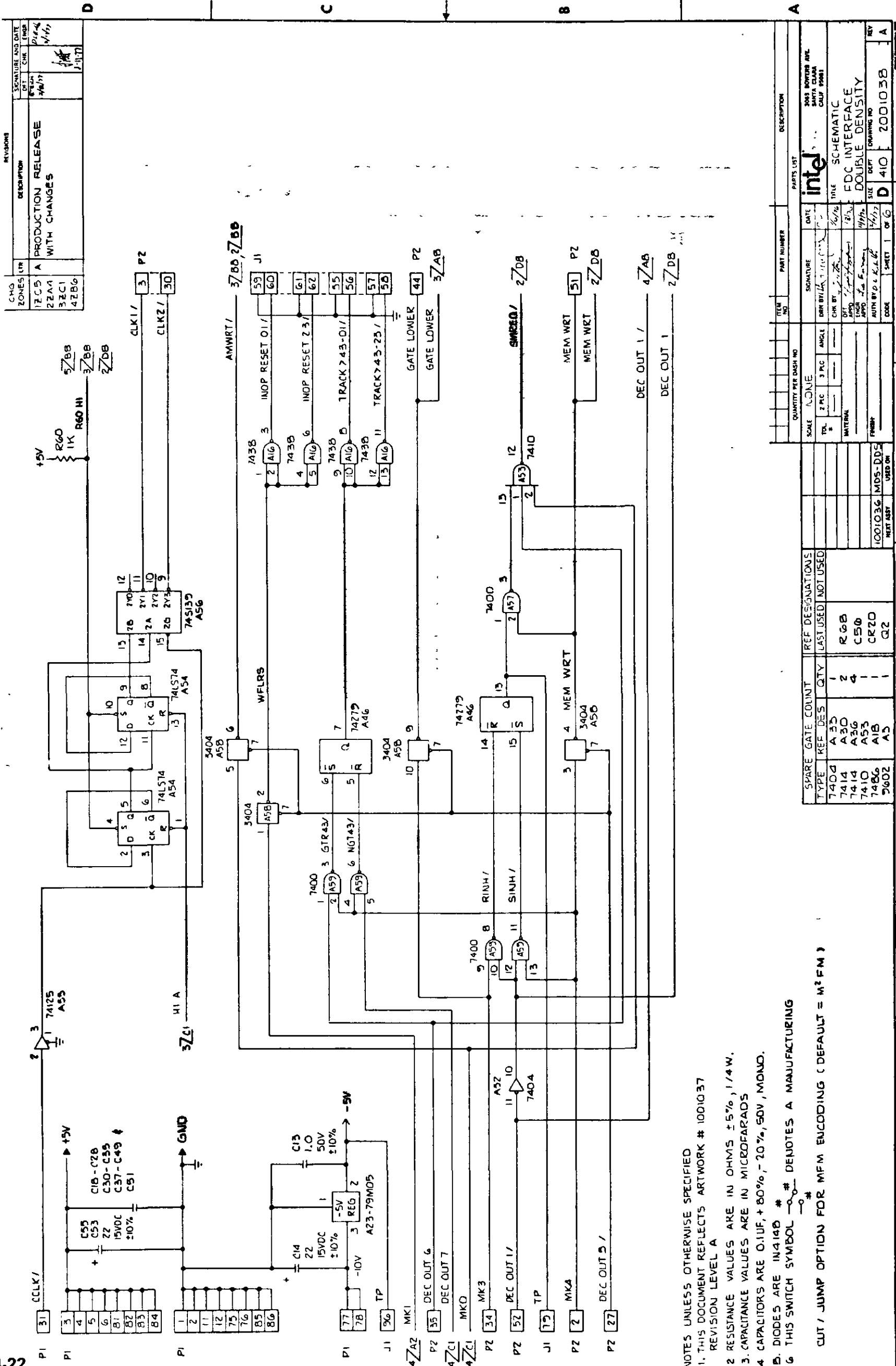

REVISIONS		SIGNATURE AND DATE	
CHG ZONES	DESCRIPTION	DESIGN	CHK
12 CS	A PRODUCTION RELEASE WITH CHANGES	4/1/77	W/H
22 AA			
32 C1			
42 B6			

- NOTES UNLESS OTHERWISE SPECIFIED
- THIS DOCUMENT REFLECTS ARTWORK # 1001037 REVISION LEVEL A
 - RESISTANCE VALUES ARE IN OHMS ±5%, 1/4 W.
 - CAPACITANCE VALUES ARE IN MICROFARADS
 - CAPACITORS ARE 0.1UF, +80%, -20%, 50V, MONO.
 - DIODES ARE IN4148 #
 - THIS SWITCH SYMBOL # DENOTES A MANUFACTURING CUT / JUMP OPTION FOR MFM ENCODING (DEFAULT = M2FM)

QUANTITY PER DASH NO		PART NUMBER		DESCRIPTION	
SCALE	ANGLE	ITEM NO	PART NUMBER	DESCRIPTION	REV
SCALE	ANGLE	ITEM NO	PART NUMBER	DESCRIPTION	REV
TOL	3 PAC				
INTERNAL					
FINISH					
1001036	MDS-DDS				
NET ASY	USED ON				
SPARE	GATE COUNT	REF DESIGNATIONS			
TYPE	REF DES	QTY	LAST USED	NOT USED	
7404	A33	1			
7414	A30	2	R6B		
7410	A36	4	C50		
7486	A18	1	CR20		
7602	A5	1	Q2		

Figure 4-11 SCHEMATIC DRAWING: INTERFACE BOARD (Sheet 1 of 6)

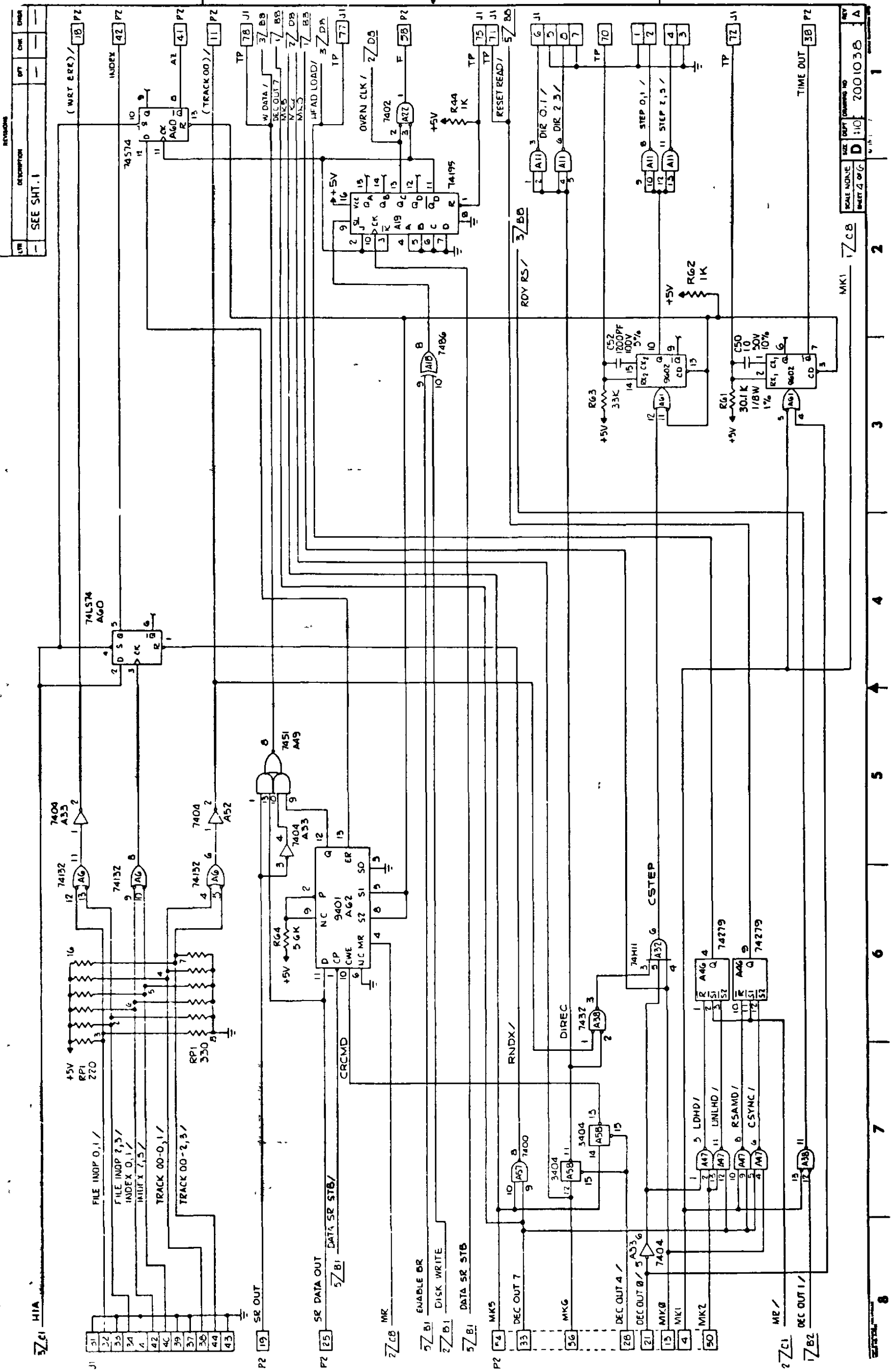

REV	DESCRIPTION	BY	CHK	DATE
1	SEE SHT. 1			

SCALE NONE	SIZE D	DEFY	DRWING NO
SHEET 4 OF 6	10		2001038

Figure 4-11 SCHEMATIC DRAWING: INTERFACE BOARD (Sheet 4 of 6)

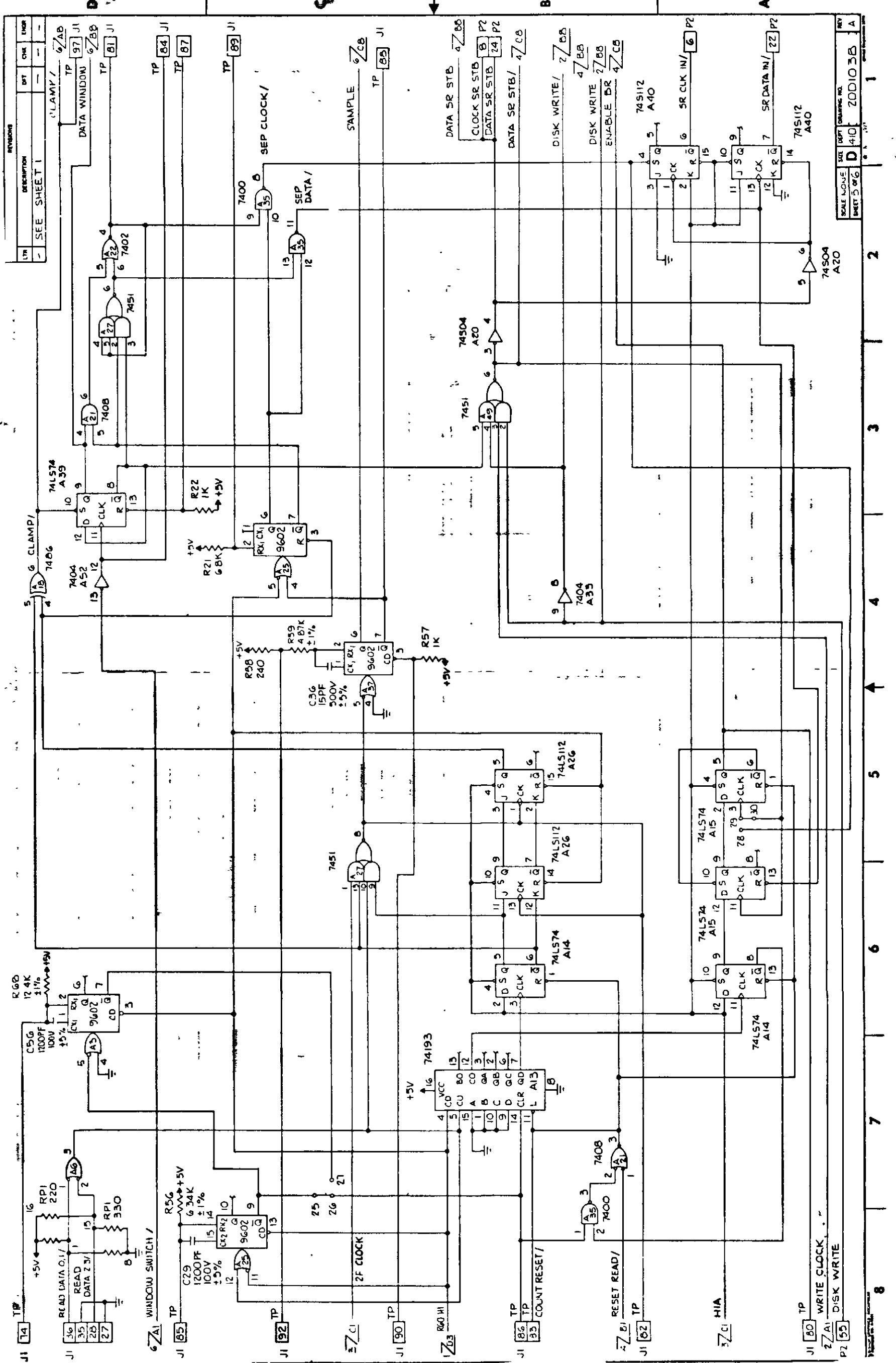

Figure 4-11 SCHEMATIC DRAWING: INTEF E BOARD (Sheet 5 of 5)

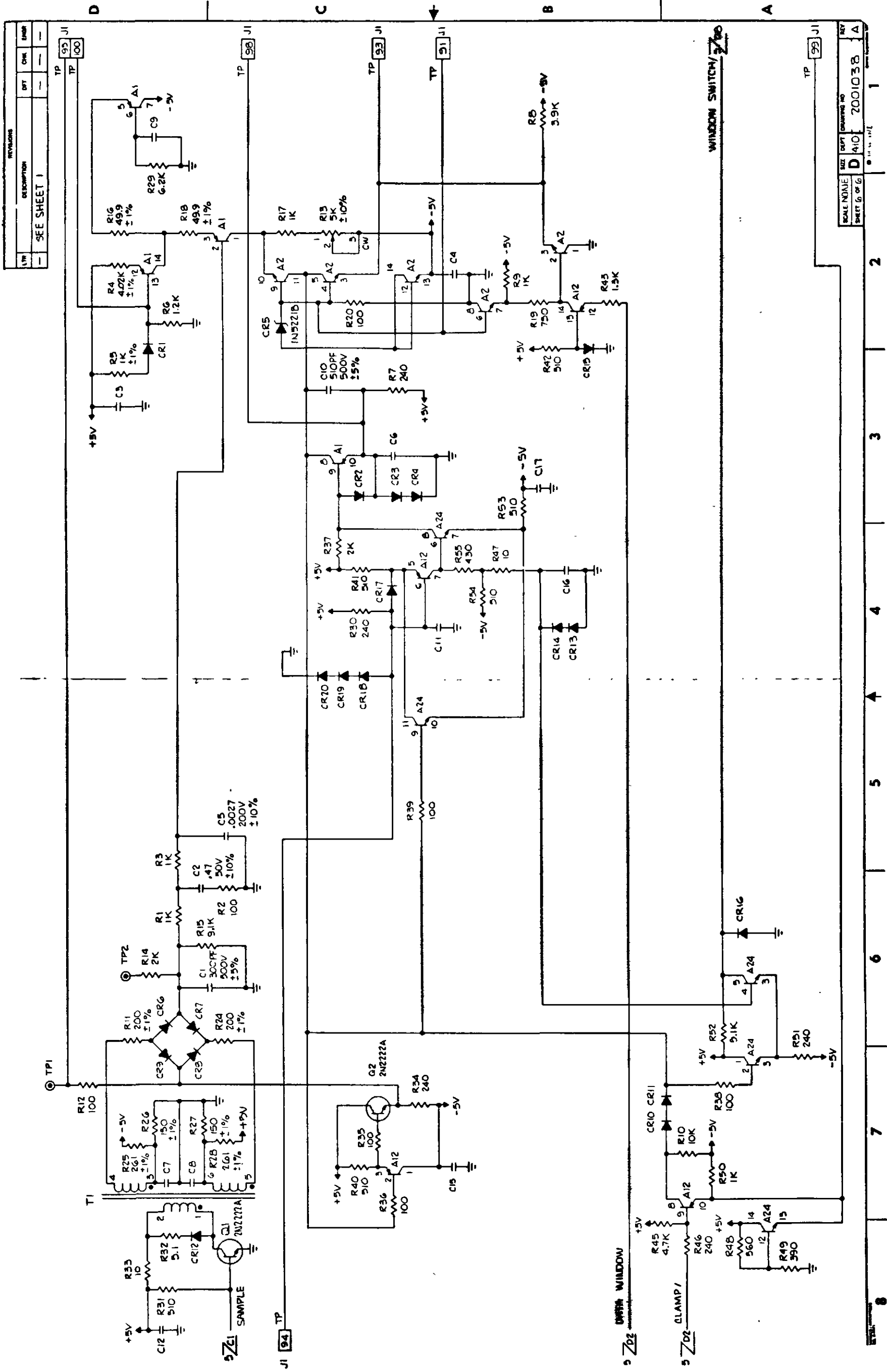

Figure 4-11 SCHEMATIC DRAWING: INTERFACE BOARD (Sheet 6 of 6)

CHAPTER 5

DISKETTE DRIVES

The Diskette System uses the Shugart Associate's SA 800-1 Flexible Disk Drive (FDD) or equivalent. The FDD is a reliable random access storage device utilizing a single, removable diskette as the storage medium. This chapter summarizes the manufacturers information on the drive. The FDD uses an IBM 3740 media compatible diskette. The disk itself is 7.88 inches in diameter and is contained in an 8 inch square protective envelope. To load the disk, the entire envelope is inserted into a slot in the FDD behind a small access cover.

Rotating at 360 rpm, data is read or written on the 77 tracks of the single recording surface at a rate of 500,000 bits per second in double density mode to provide a total unformatted capacity of 6-megabits. The single head need only be in contact with the media during actual data transfer operations. Track accessing is accomplished using a stepping motor. Index is detected using a photo-optical technique to sense the physical index hole in the disk cart-ridge.

The FDD contains all the analog read, write and control electronics necessary to perform data transfer operations using only simple control commands.

5.1 FUNCTIONAL DESCRIPTION

The following paragraphs describe the major components of the FDD.

Electronics:

All electronic circuitry required to convert from the digital I/O to the analog read/write and positioning information is contained on a single circuit board mounted underneath the deck. Logic is T²L with a minimal number of discrete analog components.

Positioner:

Positioning of the read/write head is accomplished using a stepping motor driving a lead screw shaft.

Head Loading Mechanism:

Head loading is achieved by a solenoid/pressure pad scheme. When the solenoid is activated, it releases the pressure pad arm which, in turn, pushes the disk against the read/write head.

Spindle Motor:

The spindle is belt driven from the spindle motor, which maintains a speed of 360 RPM $\pm 3.5\%$.

Disk Loading Mechanism:

Disk Loading is accomplished when the disk loading access cover is closed. A two piece expandable centering cone is loaded against the center of the disc on the side opposing the spindle, causing the disk to be located accurately between the centering cone and the spindle. The centering cone, disk, and spindle then rotate together.

Head:

The read/write head is a single gap head plus track edge erase gaps. Nominal track width is 0.013 inches.

Mechanical Framework:

A solid deck die casting provides a clean construction to enhance reliable operation. The deck casting provides for spindle housing, disk cartridge registration and envelope stabilization surfaces, drive motor mounting surfaces, stepper motor mounting surface, electronic circuit board mounting as well as providing a stable base for integration and operation of unit components. A secondary frame die casting provides stable mounting, in relationship to the main deck casting, for the disk centering cone and loading mechanism.

A simple disk loading access cover completes the disk loading/unloading mechanism and prevents the possibility of objects falling into the unit.

Diskette:

The single disk cartridge is in a sealed envelope. The envelope size is 8" x 8" with a recording disk diameter of 7.88". The FDD uses the IBM 2305830 type diskette or double density certified media such as Dyan 3740D or ITC 34-9000D.

The disk has 77 concentric recording tracks spaced .02083 inch apart on a single surface. Track centerlines are calculated by the formula: centerline radius = $2.029 + \frac{76-N}{48}$. N is the physical track number.

5.2 PERFORMANCE CHARACTERISTICS

The following sections list the performance characteristics of the FDD.

5.2.1 Recording Characteristics

M²FM, self-clocking, serial-by-bit for double density operation, providing:

Outer track (TR00)	—	3672 bits/inch
Inner track (TR76)	—	6576 bits/inch
Track density	—	48 tracks/inch

5.2.2 Bit Transfer Rate

Based on a nominal disk speed of 360 rpm, the bit transfer rate is 500,000 bits per second.

5.2.3 Data Capacity

The data capacity listed below is an unformatted maximum and will be reduced by formatting allowances for sector operation and spare track allocation.

Track capacity	—	83,328 bits
Disk capacity	—	6,416,256 bits

5.2.4 Latency Time

Latency time is the time required to reach a particular point on a track after positioning is complete. It is a function of spindle speed.

The spindle speed for the FDD is 360 RPM $\pm 3.5\%$. The speed tolerance includes motor performance, pulley tolerance, spindle variation, $\pm 10\%$ AC line voltage variation, and a $\pm 2\%$ AC line frequency variation.

Based on a nominal disk speed of 360 rpm, the average latency time is 83.33 milliseconds.

Based on a minimum disk speed of 347 rpm, (360 - 3.5%) the maximum latency time is 173 milliseconds.

5.2.5 Positioning Characteristics

The time for a single track move is 20ms including settling time. This is defined as the time to move between any pair of adjacent tracks. Multiple track moves can be made at 10ms per step plus 10ms settling time.

The random average positioning time is 260ms including settling time. This is defined as the summation of the move times for all possible moves divided by the number of possible moves.

The maximum positioning time is 770ms. This is defined as the time to move the head from track 00 to track 76 or from 76 to 00 and includes settling time.

5.2.6 FDD Start and Stop Time

The FDD spindle runs at all times while power is applied to the unit and is not stopped for disk loading or unloading. Since the time for the disk to reach the same speed as the spindle is negligible (less than 2 seconds) there is essentially no operator waiting time required.

5.2.7 Error Recovery

Read/Write Errors

To guard against degradation from imperfections in the media, it is recommended that no more than 4 attempts to write a record be used when read after write errors are encountered. In the event a record cannot be successfully written within 4 attempts, it is recommended that the sector or track be labeled defective and an alternate sector or track assigned. If more than 2 defective tracks are encountered, it is recommended that the disk be replaced.

In the event of a read error up to 10 attempts should be made to recover with re-reads. If after 10 attempts the data has not been recovered, step the head several tracks away and re-position to recover the data. If the error persists, the sequence should be attempted at least 10 times. Unloading the head when data transfers are not imminent will increase the data reliability and extend the disk life.

Seek Errors:

Seek errors will rarely occur unless the stepping rate is exceeded. In the event of a seek error, recalibration of track location can be achieved by repetitive Step Out commands until a track 00 signal is received.

5.2.8 Environmental Limits

Temperature and Humidity:

The FDD can withstand the following conditions, if the combined rate of temperature and humidity change precludes condensation of moisture on any part of the unit.

	Operating	Storage and Transit
Temperature, °F	50° to 100°	-30° to 150°
Temperature, °C	10° to 38°	-35° to 65°
Temp. Change, °F/Hr.	12	60
Temp. Change, °C/Hr.	6.7	33
Relative Humidity	20% to 80%	5% to 95%
Max. Wet Bulb Temp. °F	80	
Max. Wet Bulb Temp. °C	26.7	

5.2.9 Write Protect

Write protect uses a photo-optical sensor that senses the presence of a write protect hole in the diskette jacket (see Figure 5-4). This feature prohibits the controller from accidentally writing on a protected disk. The diskette can be written upon, if so desired, by masking the write protect hole.

5.3 INTERFACE SPECIFICATION

The following paragraphs describe the control and data interface lines, shown in Figure 5-1.

All signal lines must be terminated at the receiver with an impedance of 130 ohms, nominal. The following definitions will be used in the signal definitions:

LOGIC LEVEL	STATUS SIGNALS	COMMAND SIGNALS
High (False) (0)	2.4V min.	2.0V min.
Low (True) (1)	0.4V max.	0.8V max.

Figure 5-2 illustrates the basic driver and receiver circuits for the FDD.

Control and Data Lines to the FDD:

1. STEP

A 10 microsecond (minimum) logic 1 level pulse on this line causes the head to move one track inward or outward from the center of the disk, depending upon the state of the direction line.

2. DIRECTION

A logic 1 level on this line causes the head to move toward the center of the spindle when a step signal occurs.

3. **UNIT SELECT 1, 2**

Two unit select lines are used by the controller to select the appropriate drive. These two lines are mutually exclusive; only one drive can be selected at a time. The lines must remain active during any command from the controller. Logical Unit assignment is accomplished by means of the unit select jumpers on the drive Printed Circuit Board and the appropriate signal adapter PCB attached to the drive (either drive 0 or 1).

4. **WRITE ENABLE**

To enable the FDD write driver, this line is held at a logic 1.

To disable the FDD write driver and enable the FDD read circuitry, this line is held at logic 0.

5. **WRITE FAULT RESET**

A logic 1 level on this line clears the Write Fault Latch. This signal is not used on the SA 800-1 drive.

6. **WRITE DATA (REFER TO FIGURE 5-3)**

This line contains the double-density encoded Write Clock and Data information to the FDD. The Write Clock and Data Pulses must be 250 nanoseconds \pm 20% in length and are true at the logic 1 level. Information to be recorded on the disk is derived from the leading edge of each pulse (i.e., at the logic 0 to logic 1 transition point).

7. **LOW CURRENT**

A logic 1 level on this line causes reduced write current to be used during a write operation. Low current should be true for all tracks greater than 43 (inner tracks). It is not necessary to gate low current with write enable in the controller. This signal is not used on the SA 800-1 drive.

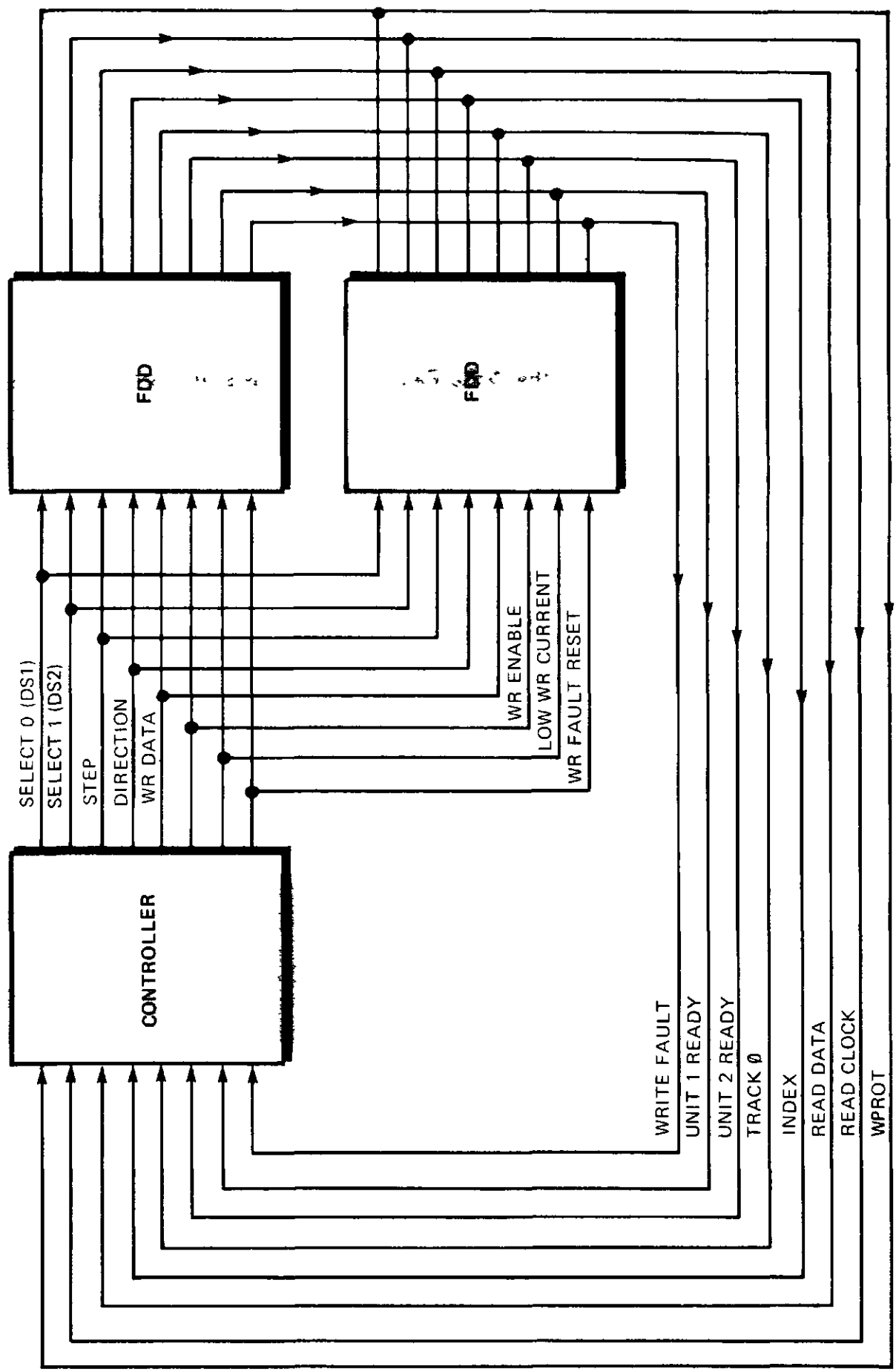

NOTE. FOR FOUR DRIVE OPERATION THE CABLING SHOWN IS DUPLICATED FOR AN IDENTICALLY CONFIGURED SECOND DRIVE BOX.

Figure 6-1 FDD/FDCC INTERFACE LINES

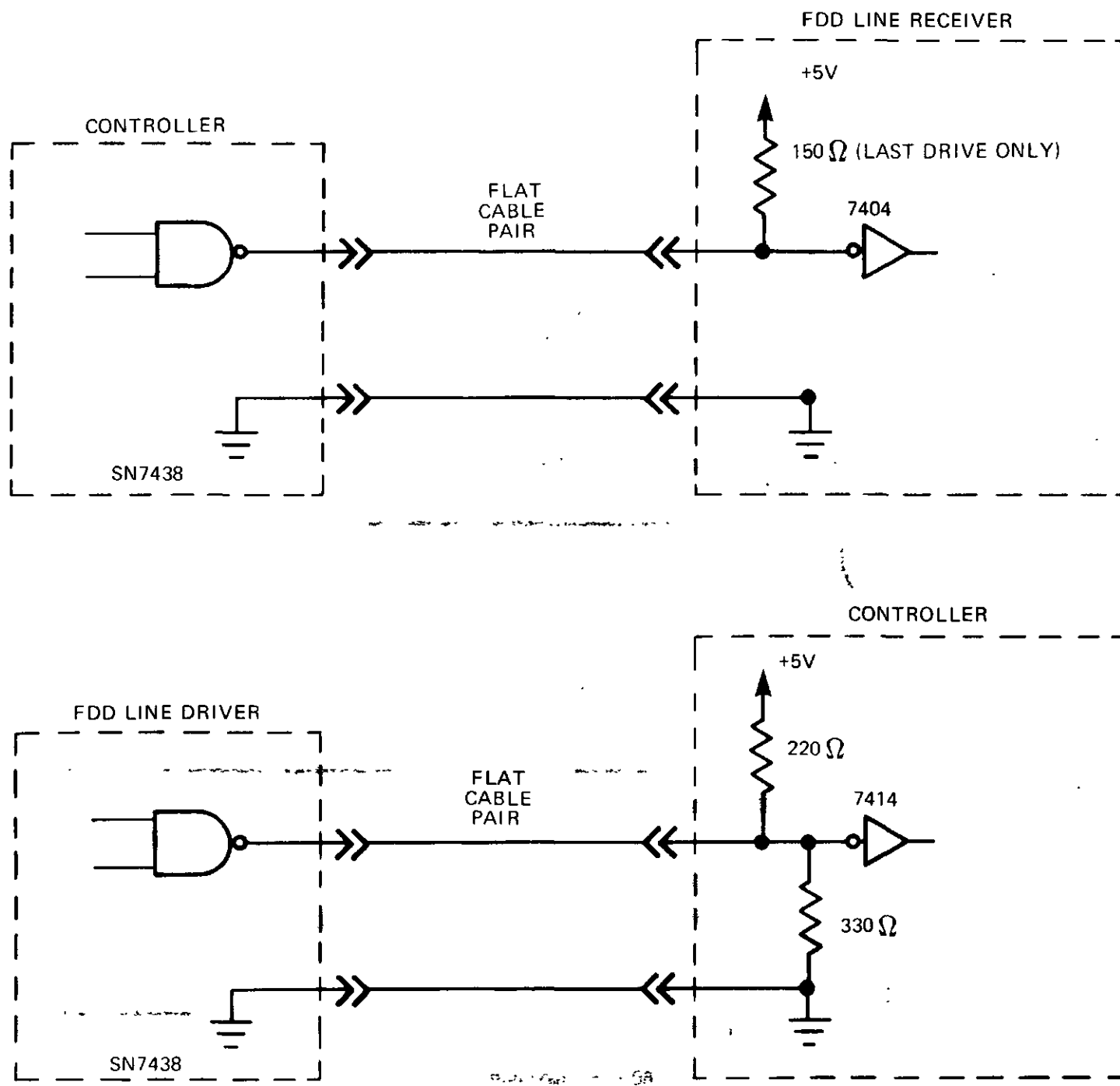

Figure 5-2 FDD DRIVER/RECEIVER CIRCUITS

Control and Data Lines from the FDD:

1. INDEX

This line gives an indication of the relative position of the disk by outputting a logic 1 pulse for every revolution of the disk. The pulse of 1.5 ± 0.7 milliseconds is generated by sensing the index hole in the disk using a photo-optical technique.

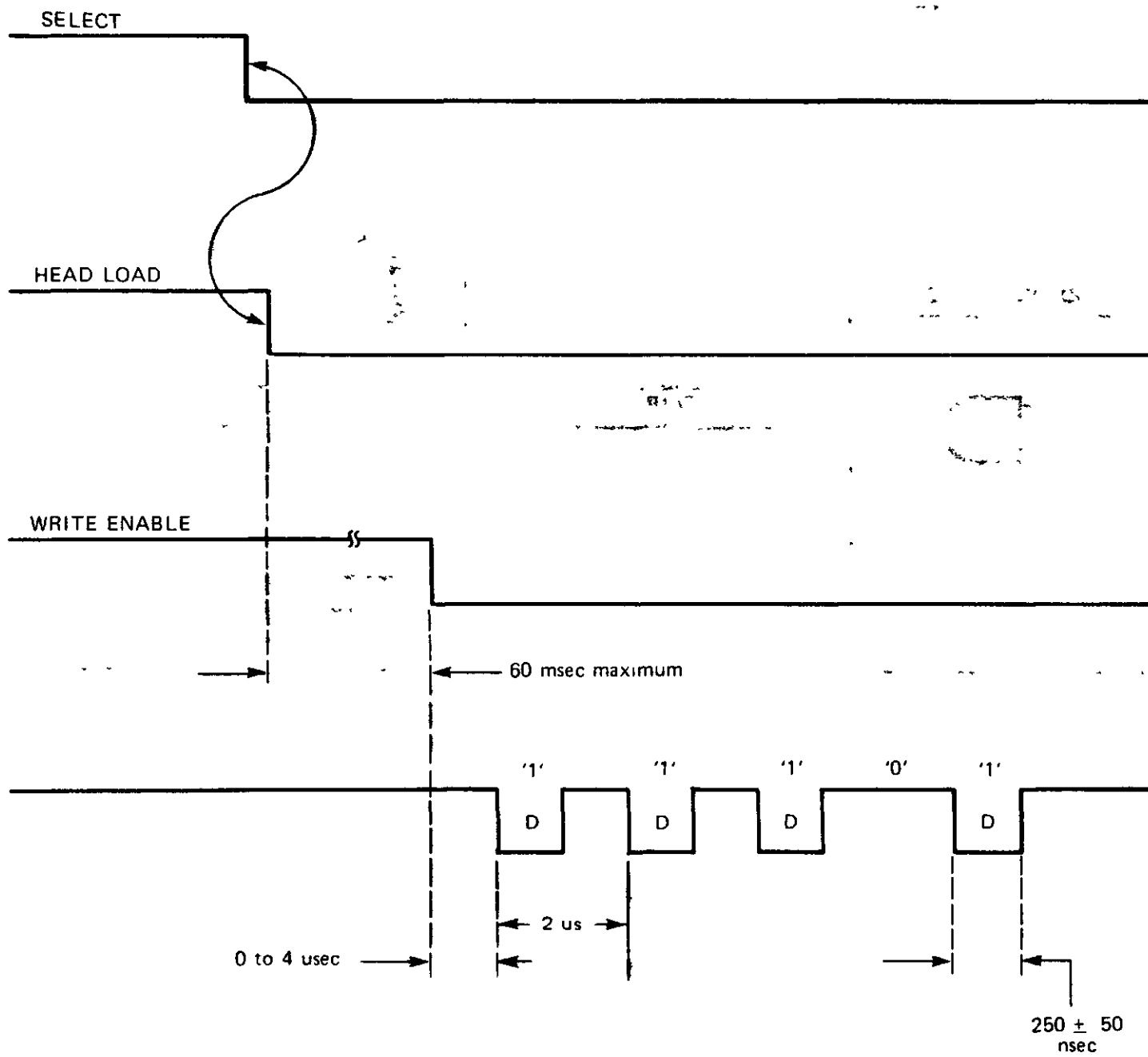

Figure 5-3 WRITE DATA TIMING

2. WRITE FAULT

A logic 1 level on this line indicates one or more of the following fault conditions:

- write enable without head load.
- write enable without write data.

NOTE: Erase current signal is derived internally on PCB from the write enable input line. Erase current is on automatically during writing.

A fault on this line can be cleared by a logic 1 on the Write Fault Reset line to the FDD. This signal is not used on the SA 800-1 drive.

3. TRACK 00

A logic 1 level on this line indicates that the head is positioned over track 00.

4. READ DATA (REFER TO FIGURE 5-4)

This line contains the composite data and clock information. A logic 1 level pulse of $250 \text{ nsec} \pm 20\%$ corresponds to a data bit or clock bit. This information is decoded within the controller.

5. UNIT READY INTERRUPT 1, 2

There are two Unit Ready Interrupt lines, one from each unit, indicating that the unit power is on, the door is closed and the diskette has reached its final speed. The Unit Ready Interrupt assignments are accomplished by attaching the 'drive 0' or 'drive 1' signal adapter PCB.

6. WRITE PROTECT

This line will be a logical 1 when the write protect hole in a diskette jacket is present. When logical 1 this line will disable write and erase current circuitry. (For hole location, refer to Figure 5-5).

5.4 DISKETTE CARTRIDGE STORAGE AND HANDLING

The disk performs well when given reasonable care. The same handling specified for computer magnetic tape should be followed. Some specific areas are as follows:

When not in the unit, keep the disk in the protective envelope. Place the disk in the envelope before writing on the label so that the label is visible through the cut-away front of the envelope.

Always handle the disk by the label area to avoid touching the mylar surface.

Keep all magnets away from disk. Magnetic fields can destroy recorded data on the disk.

Do not touch or attempt to clean the disk surface. Abrasion may result in loss of stored data.

7.740 047 * 2.2 4470

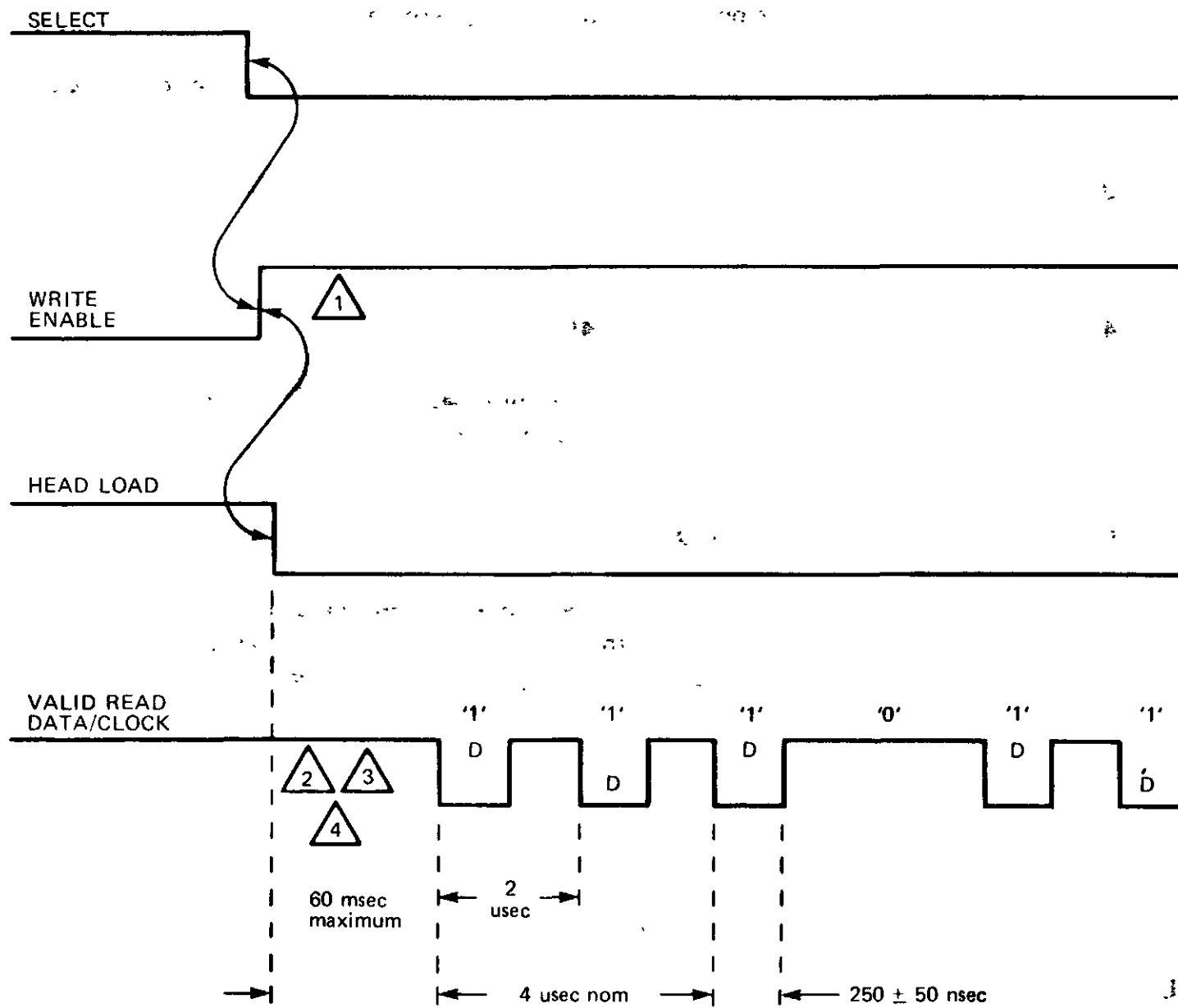

- 1 When WRITE ENABLE IS HIGH read operation is implied.
- 2 During this time interval READ DATA/CLOCK is to be ignored.
- 3 Subject to $\pm 3.5\%$ speed tolerance.
- 4 For product acceptance purposes any two adjacent bits may be subject to ± 300 nsec bit shift from this nominal position.

Figure 5-4 READ DATA TIMING

5.5 DISKETTE CARTRIDGE WRITE PROTECT NOTCH

Each flexible disk drive is equipped with a write-protect sensor which prohibits the writing of data on a diskette. A write-protect notch is located on the sealed diskette envelope (see Figure 5-5). Data may be written on such diskettes if the write-protect notch is completely covered by an opaque material such as masking tape. The diskettes shipped with the DDS have masked write-protect notches; removal of the opaque tape will yield a write-protected diskette.

5.6 ADDITIONAL INFORMATION

Additional information can be obtained from the Customer Maintenance Manual which accompanies each drive.

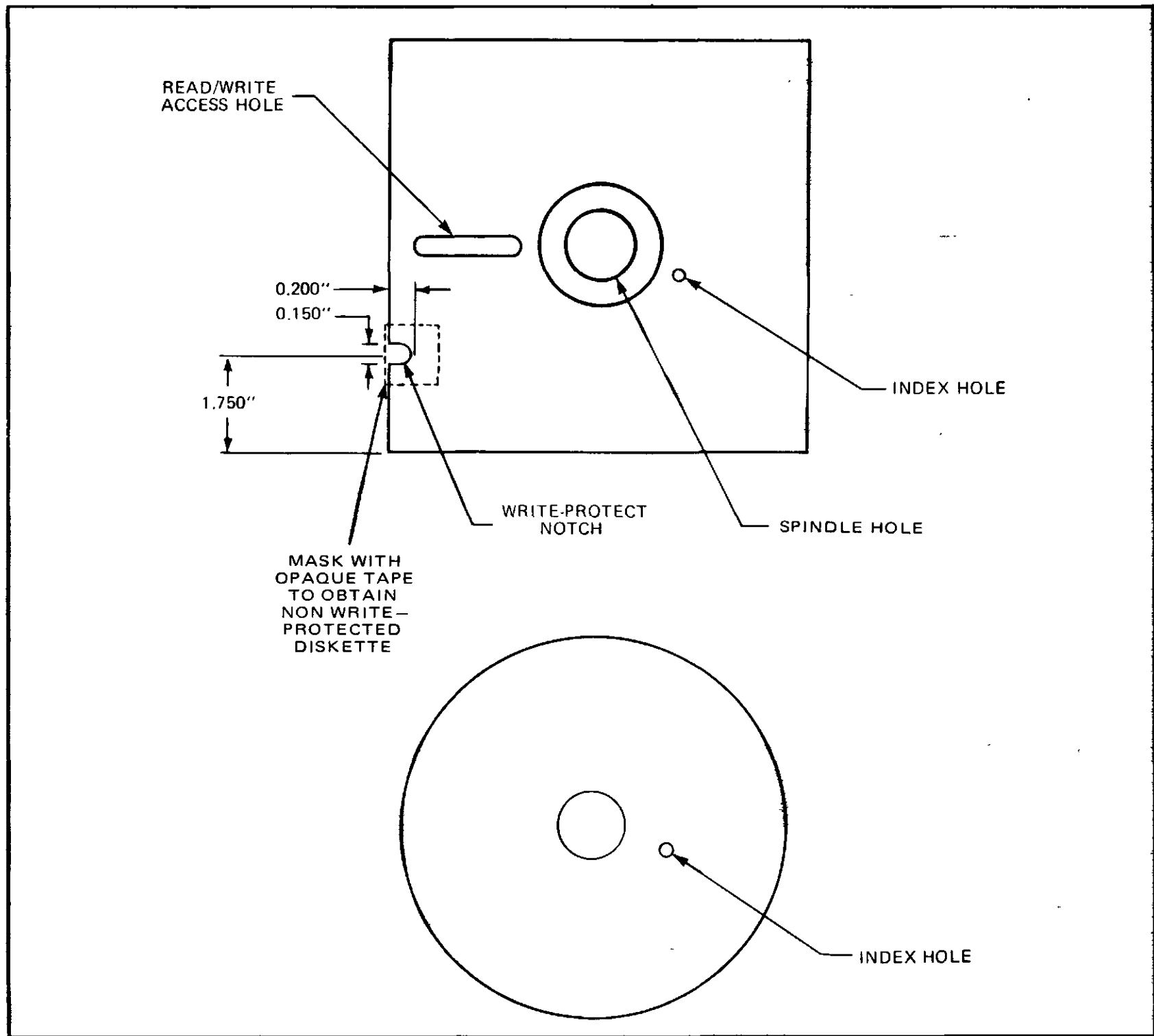
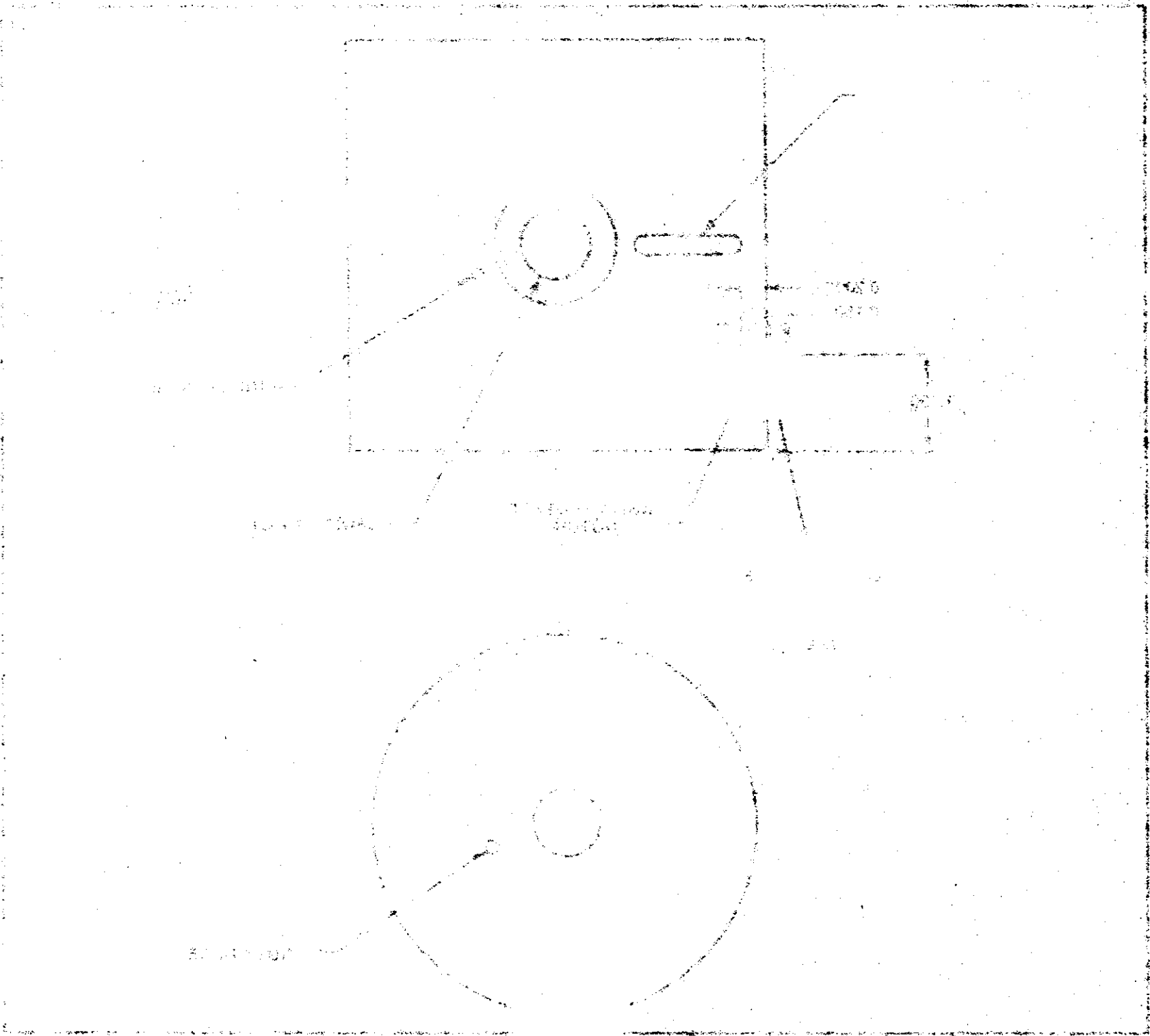

Figure 5-5 DISKETTE CARTRIDGE

FIG. 1 is a perspective view of the device showing the housing 10 and the handle 12. The handle 12 is connected to the housing 10 by a hinge 14. The housing 10 is provided with a window 16 and a door 18. The door 18 is provided with a handle 20. The device is provided with a motor 22 and a fan 24. The motor 22 is connected to the fan 24 by a shaft 26. The motor 22 is provided with a winding 28 and a commutator 30. The fan 24 is provided with a blade 32 and a hub 34. The device is provided with a power cord 36 and a plug 38. The device is provided with a switch 40 and a fuse 42. The device is provided with a battery 44 and a terminal 46. The device is provided with a terminal 48 and a terminal 50. The device is provided with a terminal 52 and a terminal 54. The device is provided with a terminal 56 and a terminal 58. The device is provided with a terminal 60 and a terminal 62. The device is provided with a terminal 64 and a terminal 66. The device is provided with a terminal 68 and a terminal 70. The device is provided with a terminal 72 and a terminal 74. The device is provided with a terminal 76 and a terminal 78. The device is provided with a terminal 80 and a terminal 82. The device is provided with a terminal 84 and a terminal 86. The device is provided with a terminal 88 and a terminal 90. The device is provided with a terminal 92 and a terminal 94. The device is provided with a terminal 96 and a terminal 98. The device is provided with a terminal 100 and a terminal 102.



CHAPTER 6

DISKETTE SYSTEM MICROPROGRAM

6.1 INTRODUCTION

The Diskette Operating System microcode consists of 512 words x 32 bits. The bit description can be found in Table 3-2. The microcode is organized functionally as modules. There are two types of modules – primary and subroutine. Primary modules, in general, implement high level functions while subroutines implement specific lower level functions. A specific subroutine may be invoked by many primary modules, but no subroutine can itself invoke another subroutine.



The primary modules within the microcode are as follows:

INIT	–	Initialization
ML	–	Mainline
MAL	–	Load M.A. Lower
STIO	–	Load M.A. Upper and Start I/O
RR	–	Read Result Byte
IOPB	–	IOPB Loader/Op Decode
FIN	–	I/O Finish
SEEK	–	Seek
FMT	–	Format
REC	–	Recalibrate
VERF/RD	–	Verify/Read
WDEL/WT	–	Write Deleted/Write

The subroutine modules within the microcode are as follows:

CHKR	–	Address Parameter Checker
INC	–	Read Next Memory Word
WDAT	–	Write Data Field
WCURR	–	Write Current Check
TO	–	Time Out
AM	–	Address Mark Detect
MVR	–	Head Stepper
TNIBS	–	Read Disk Byte
ID	–	Process Address (ID) Field
WADD	–	Write Address Field

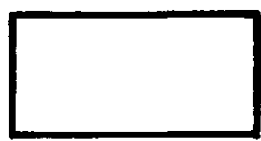
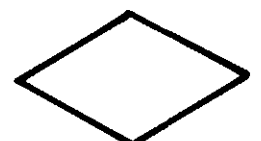
The following conventions will be used throughout:

	–	Denotes a command or data transfer
	–	Denotes a decision block
	–	Denotes a transfer of control to another module

6.2 MICROPROGRAM MODULE DESCRIPTION

The following flow charts describe each module in detail.

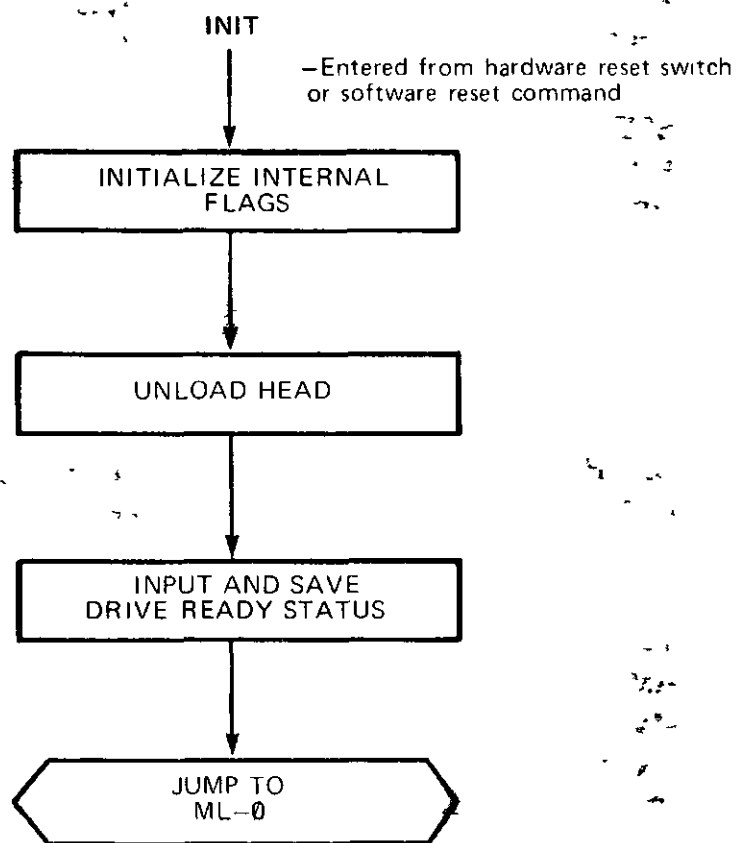

Figure 6-1 INITIALIZATION

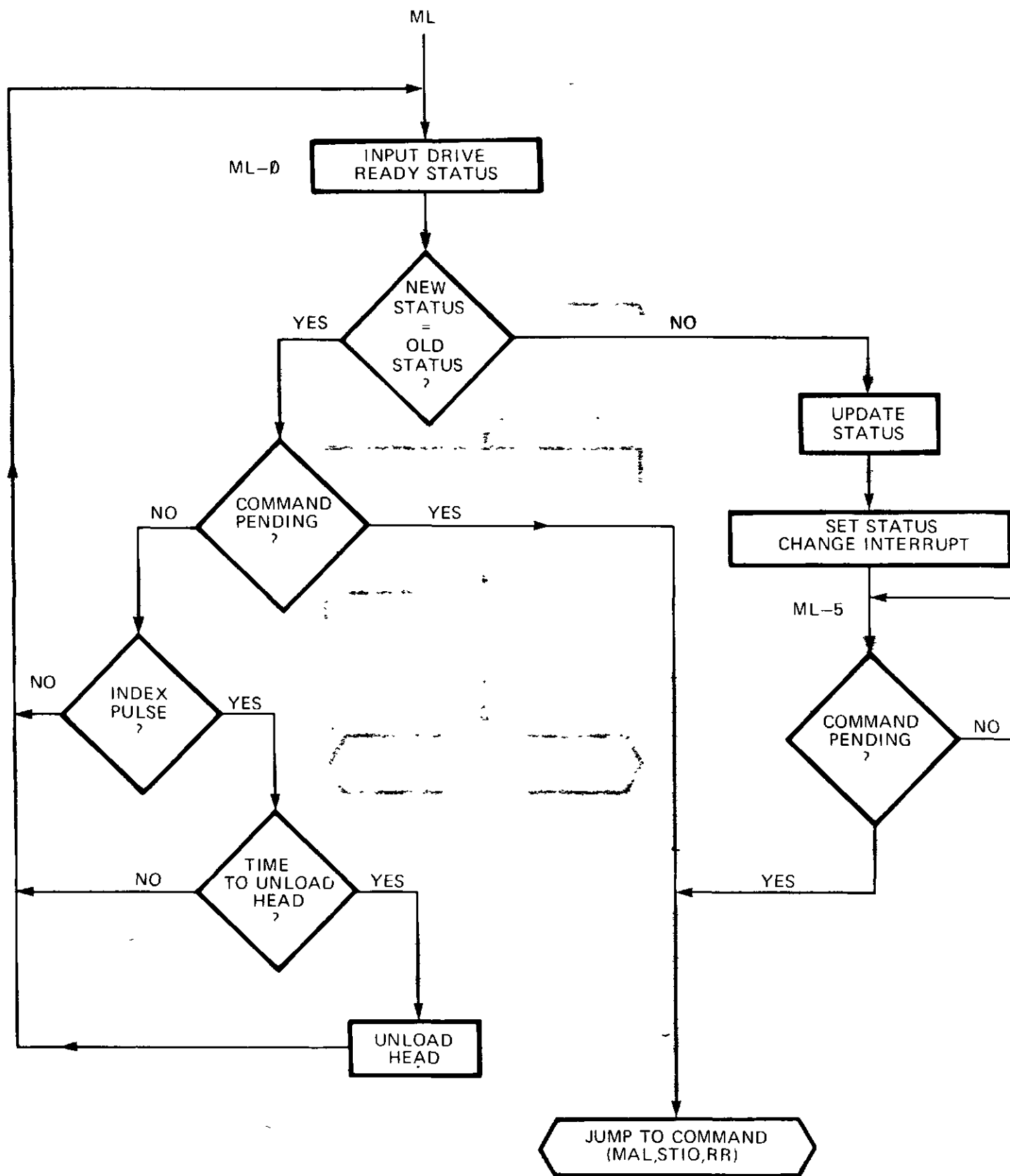

Figure 6-2 MAINLINE

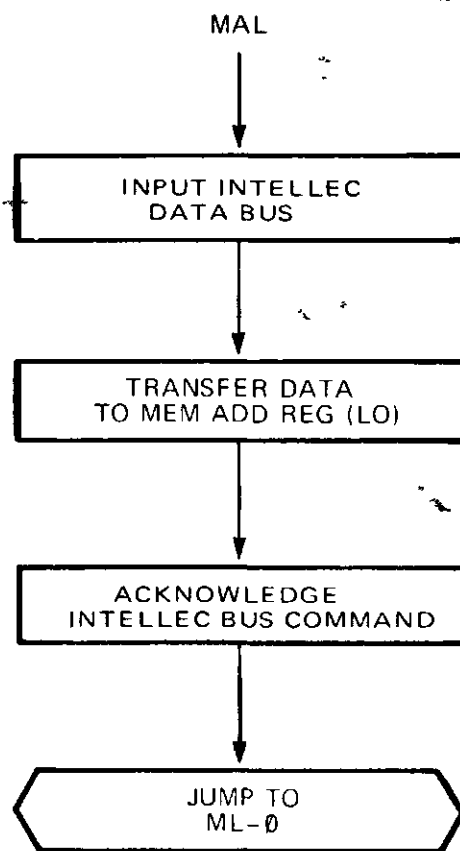

Figure 6-3 LOAD MA LOWER

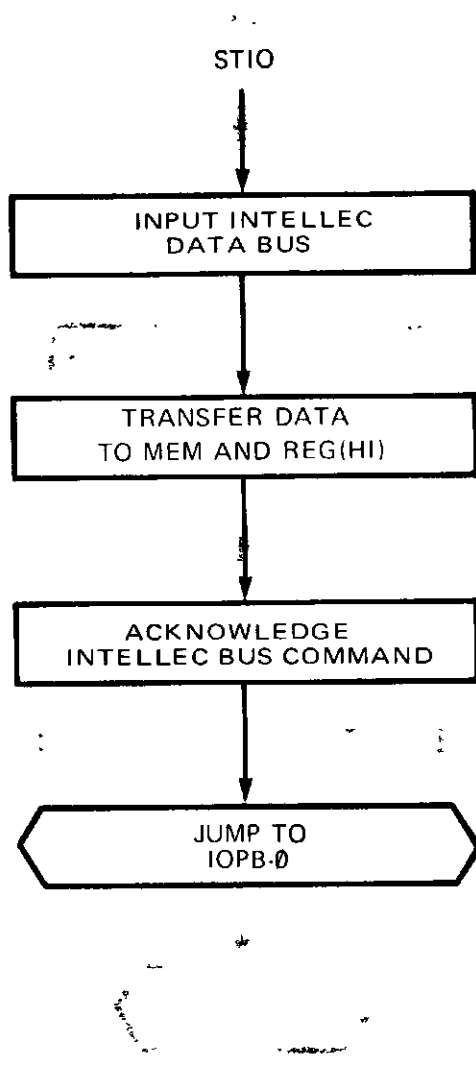

Figure 6-4 LOAD MA UPPER AND START I/O

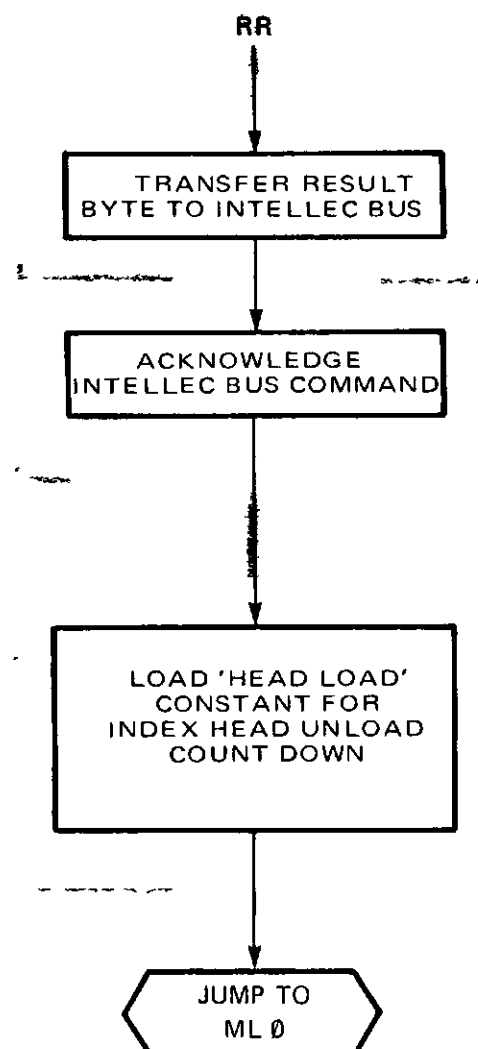

Figure 6-5 READ RESULT BYTE

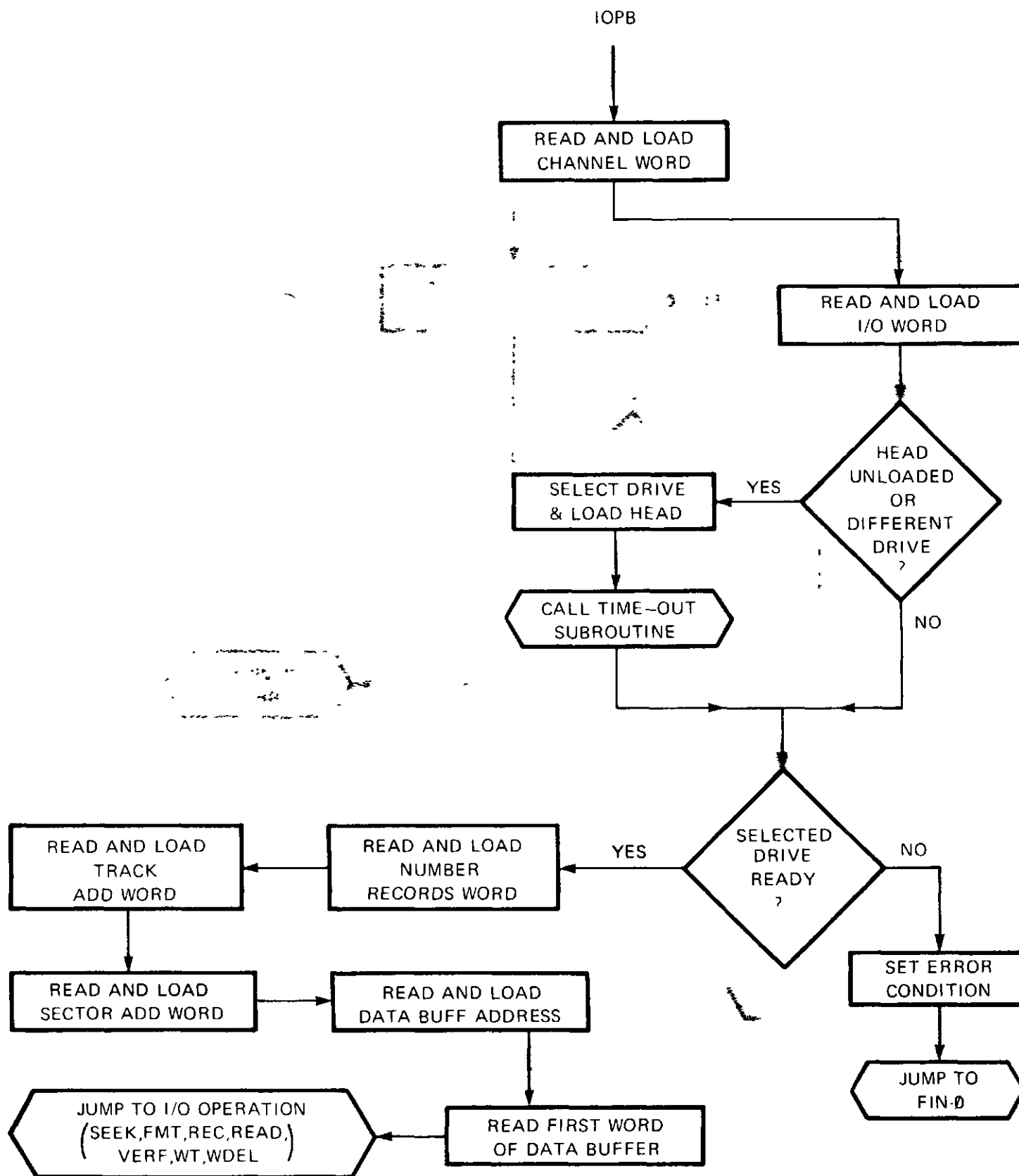

Figure 6-6 IOPB LOADER/OP DECODE

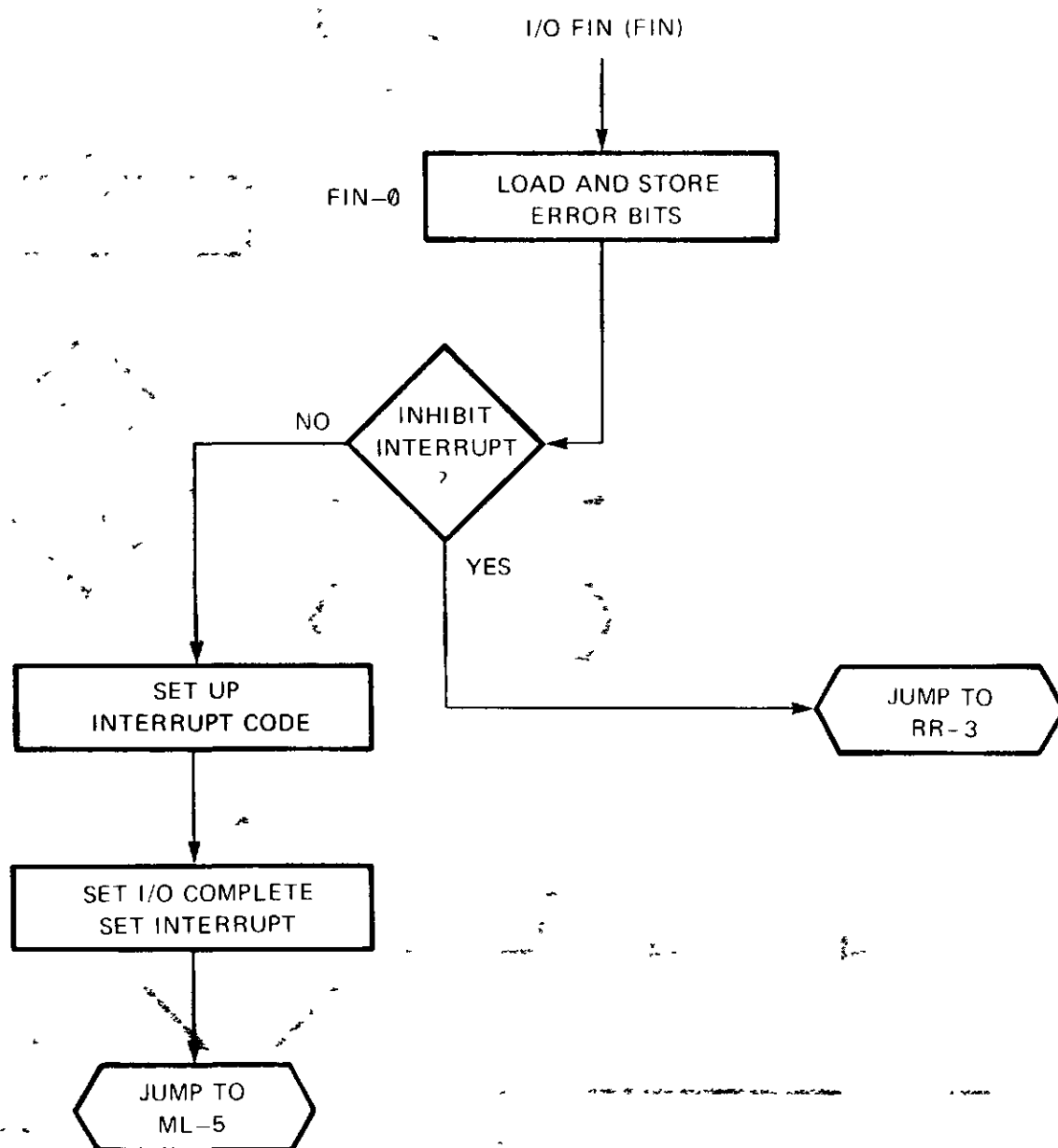

Figure 6-7 I/O FINISH

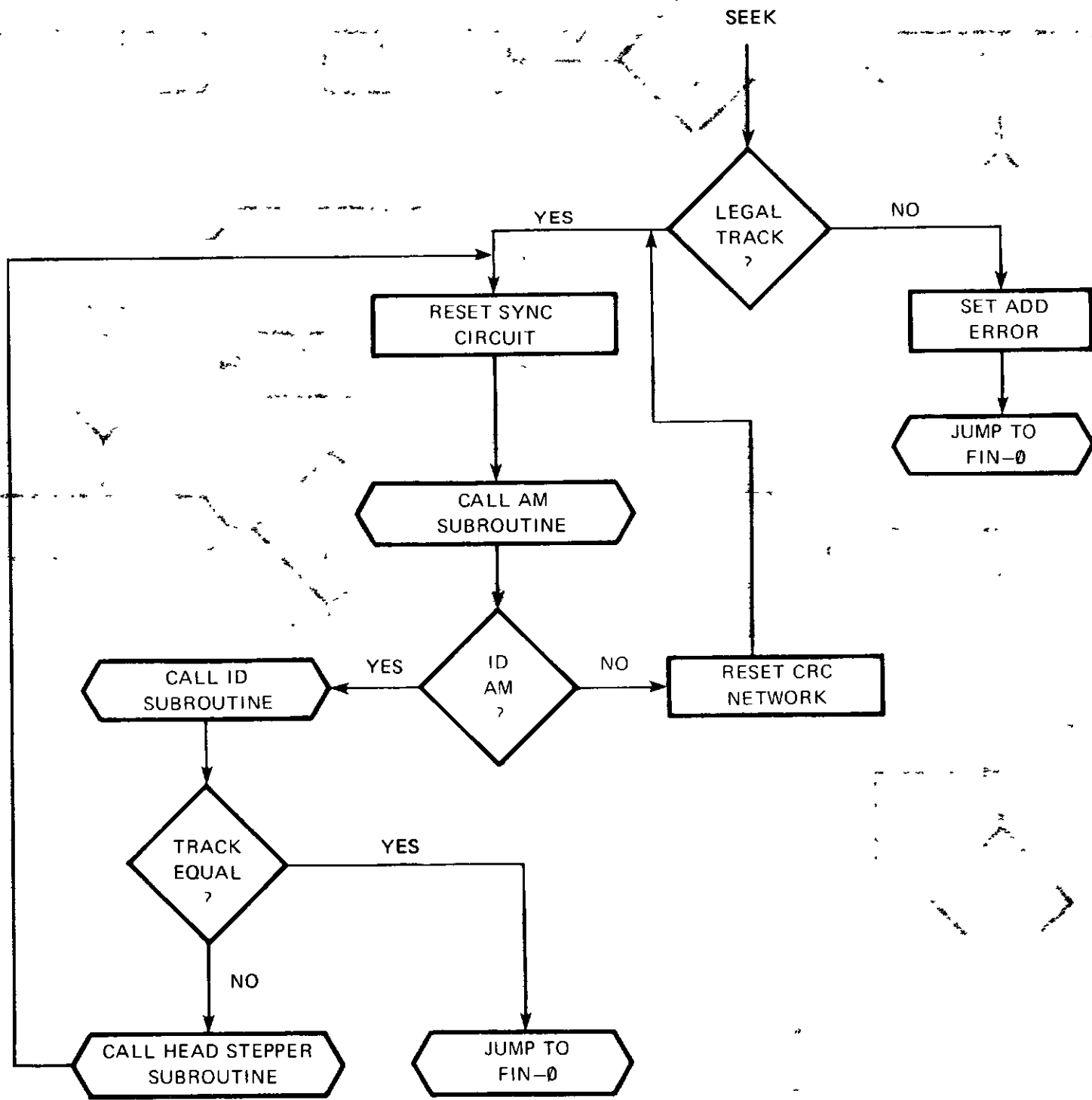

Figure 6-8 SEEK

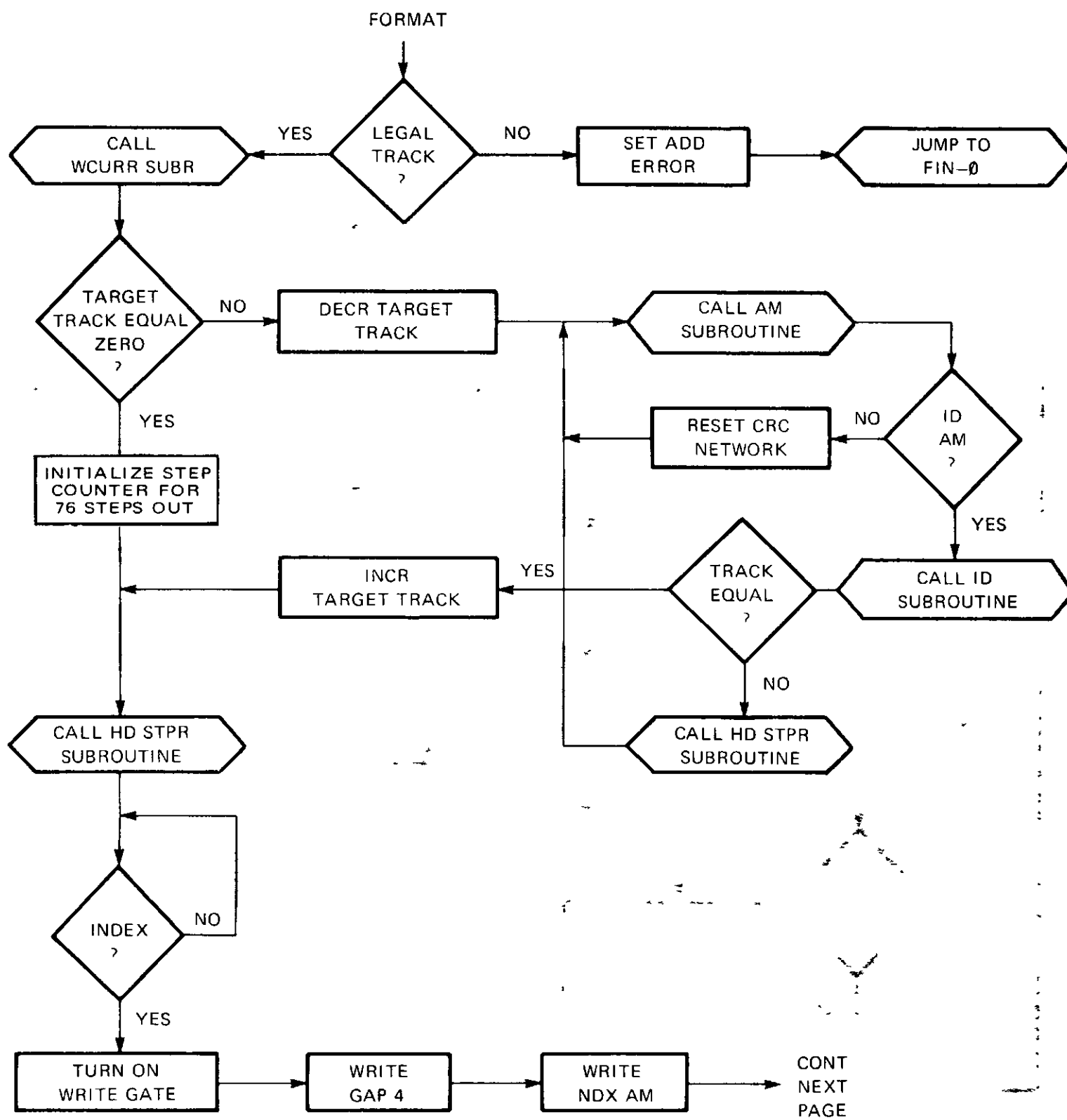

Figure 6-9 FORMAT

CONT.
FROM
PAGE 6-10

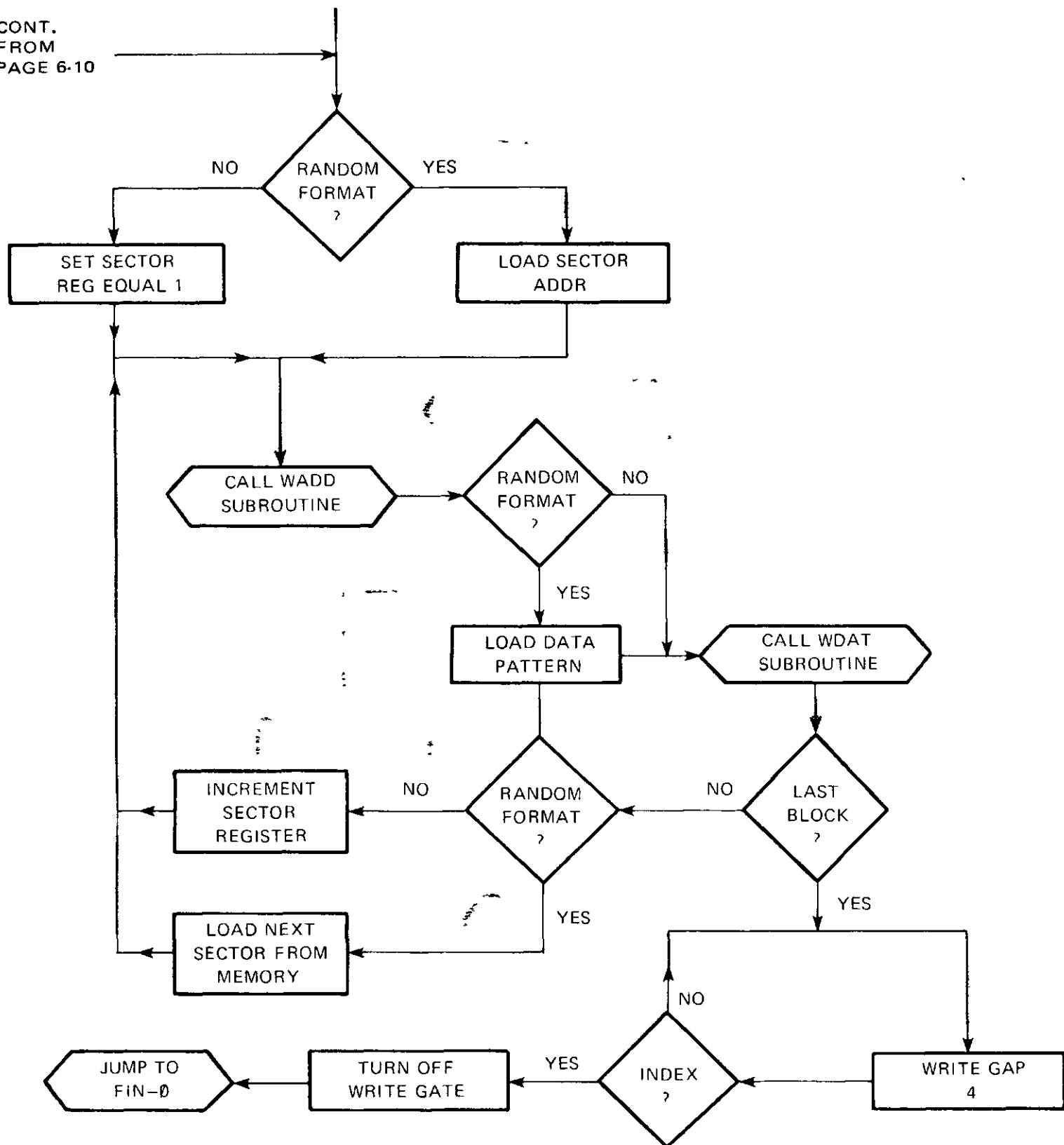
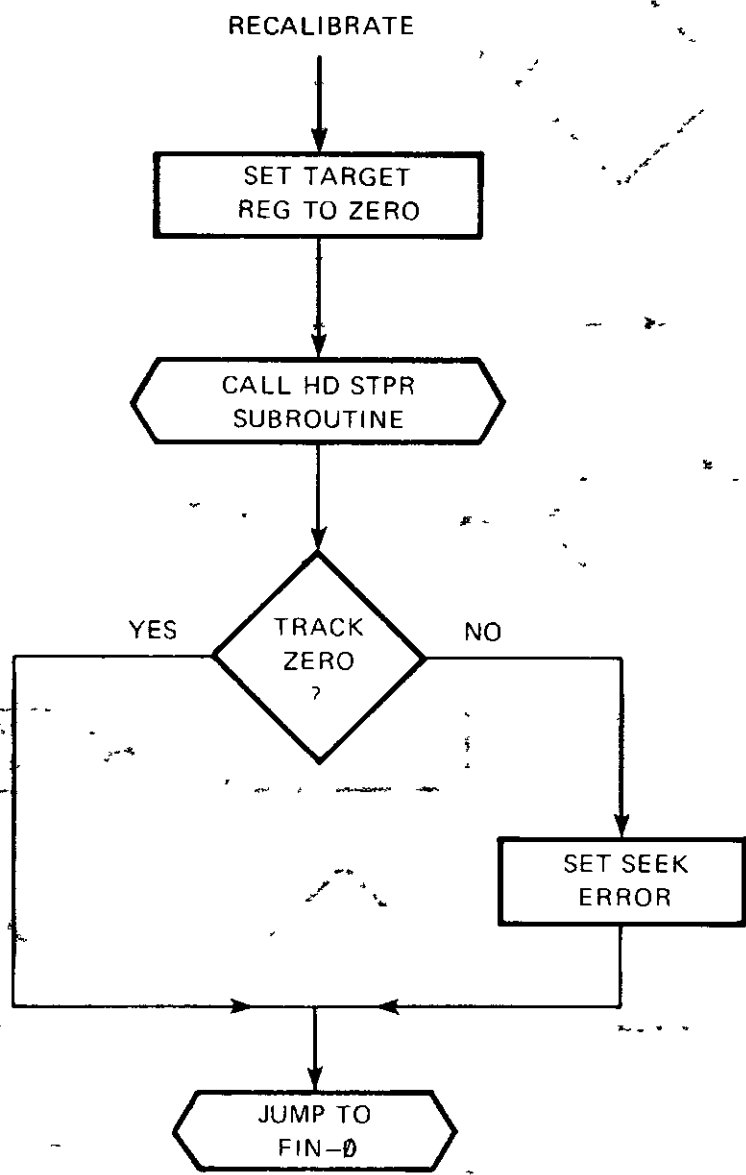
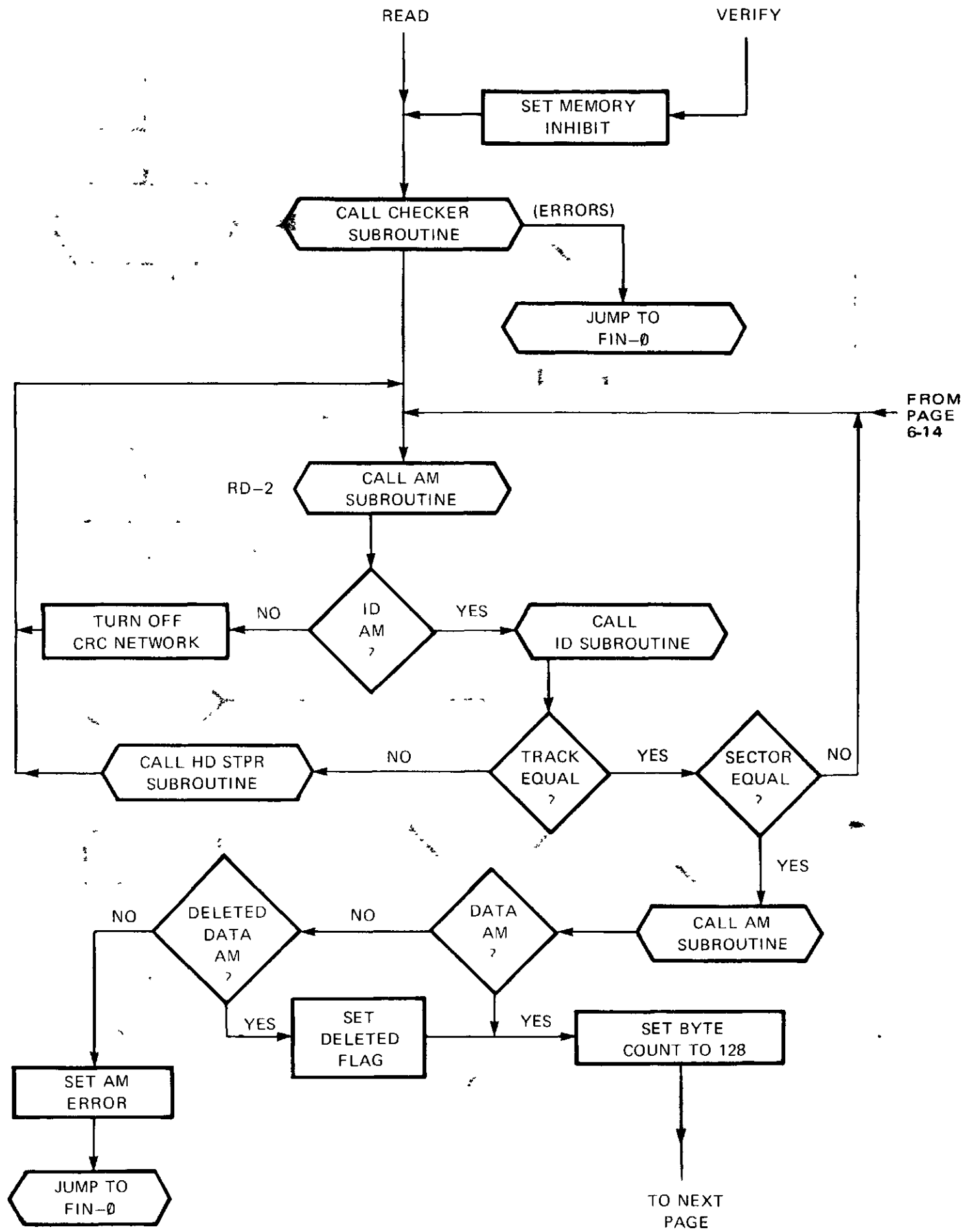

Figure 6-9 FORMAT (CONTINUED)



.. Figure 6-10 RECALIBRATE



FROM PAGE 6-14

Figure 6-11 VERIFY/READ

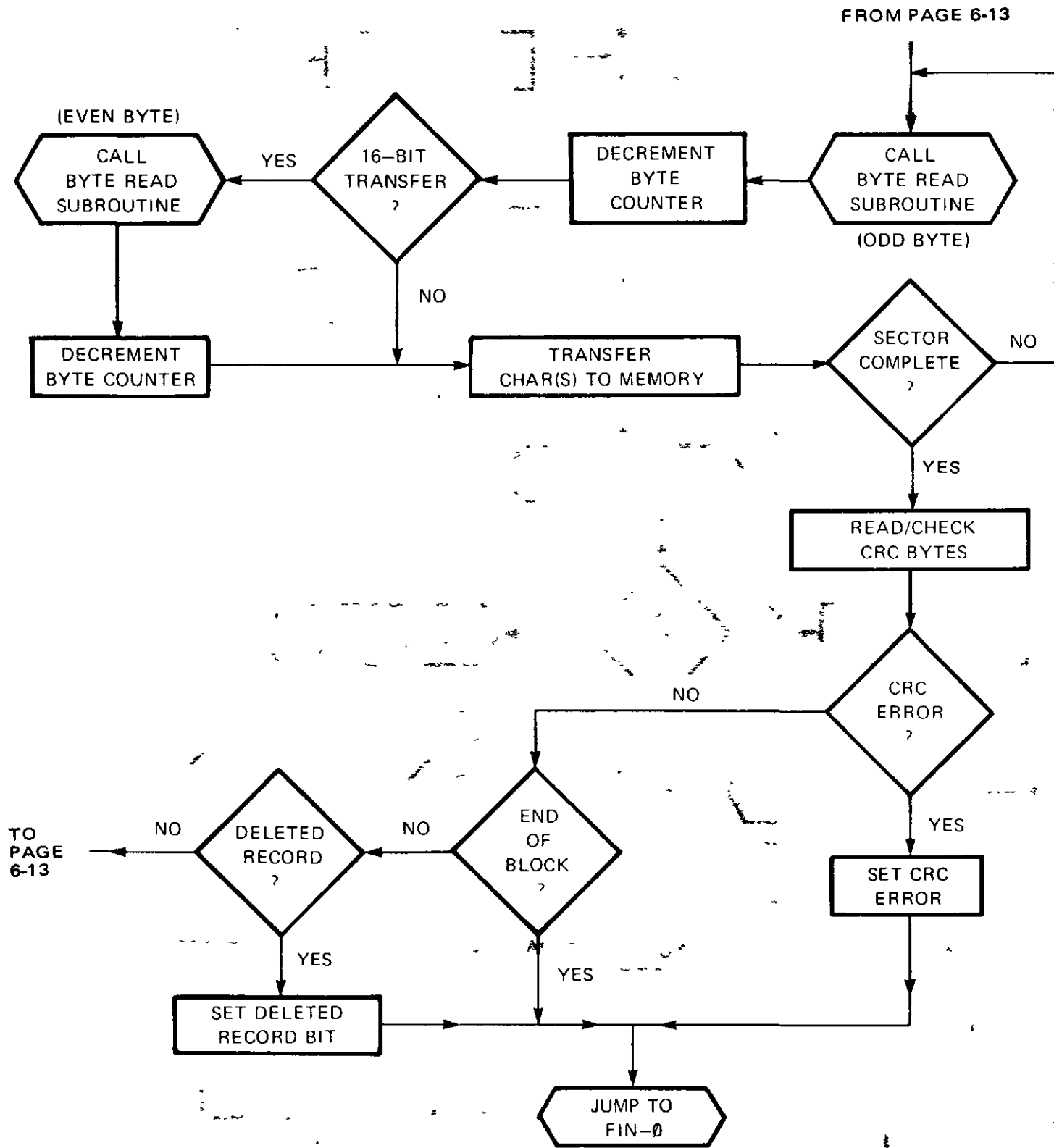

Figure 6-11 VERIFY/READ (CONTINUED)

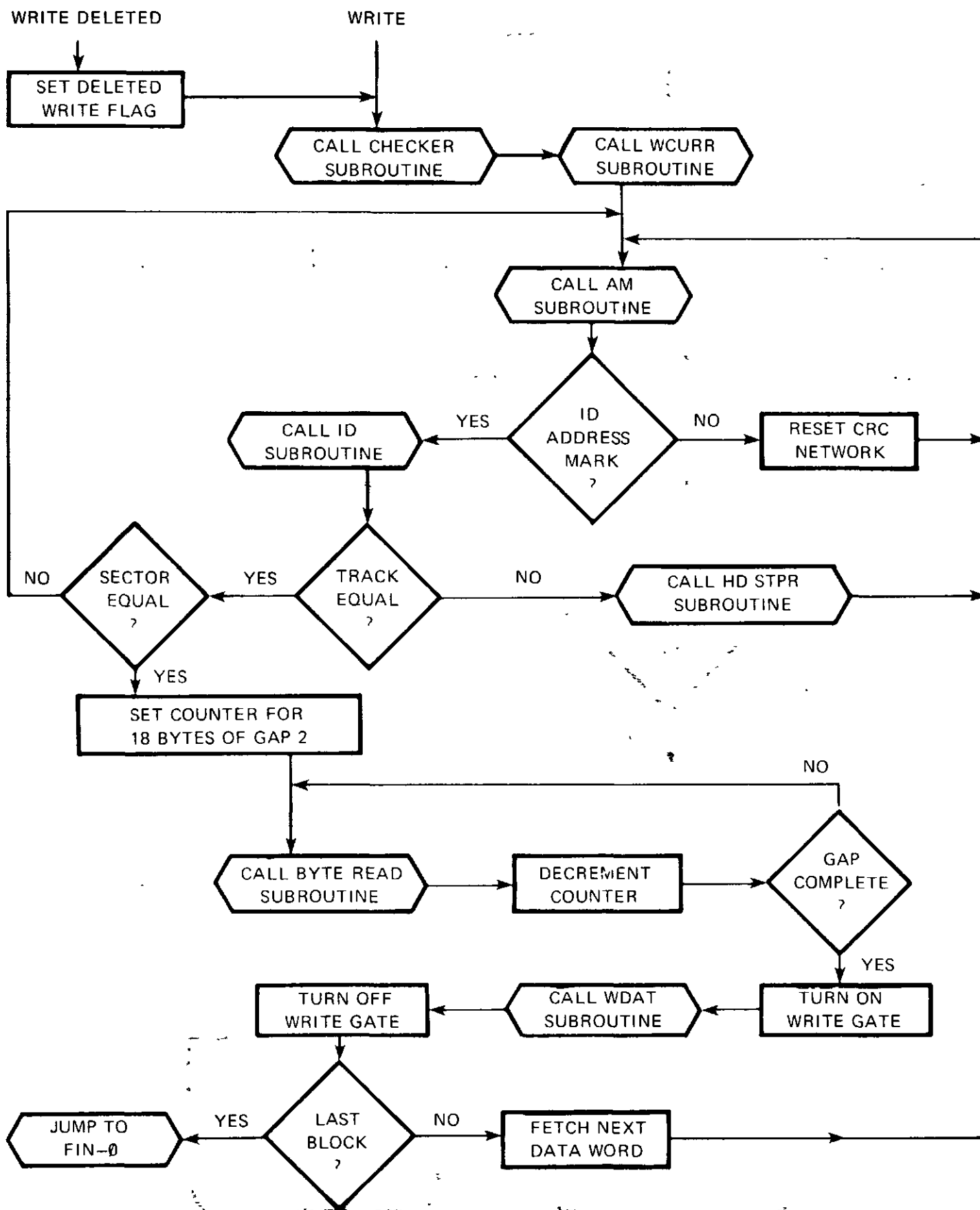

Figure 6-12 WRITE DELETED/WRITE

ADDRESS PARAM CHECKER (CHECKER)

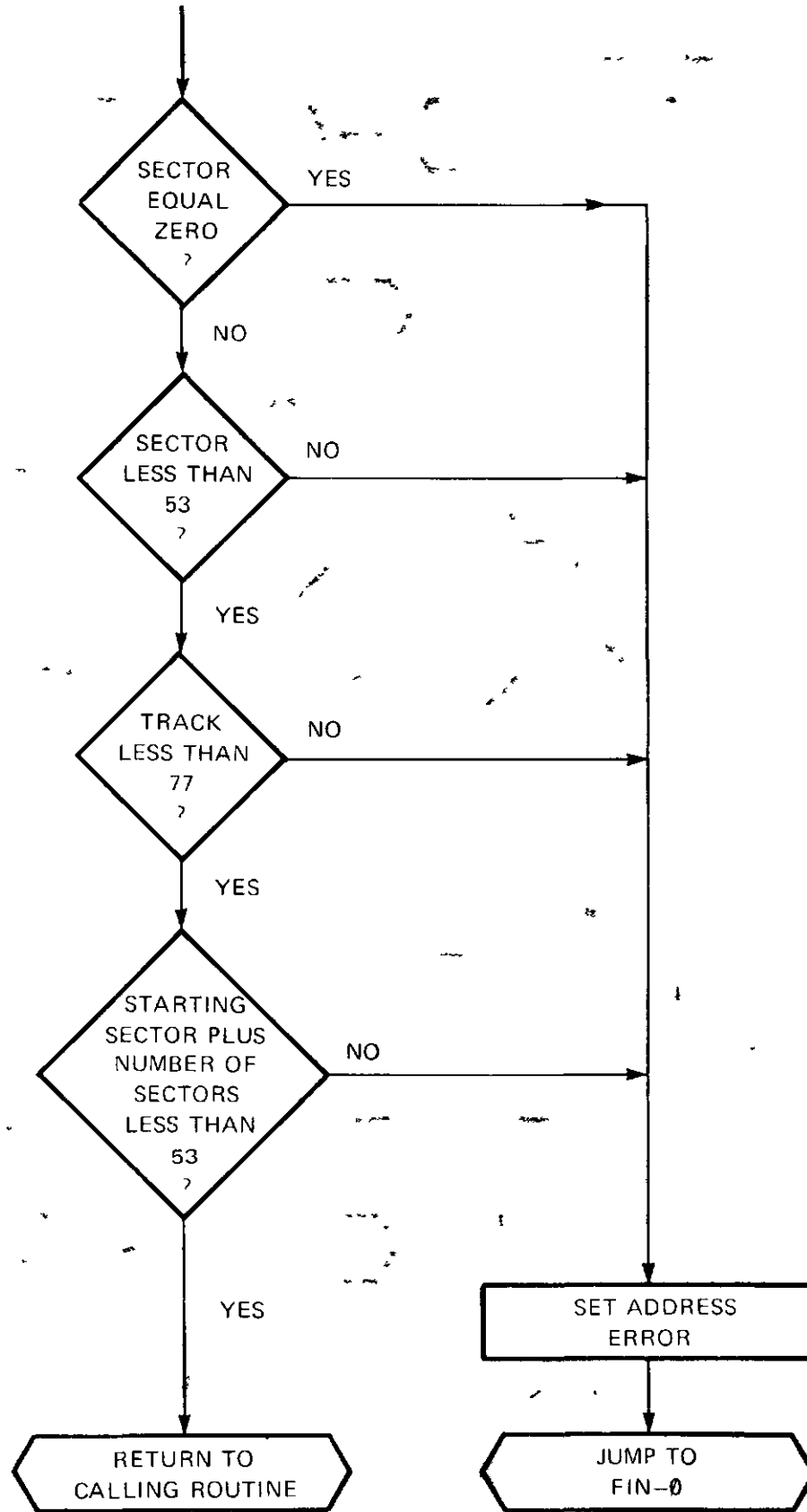

Figure 6-13 ADDRESS PARAMETER CHECKER

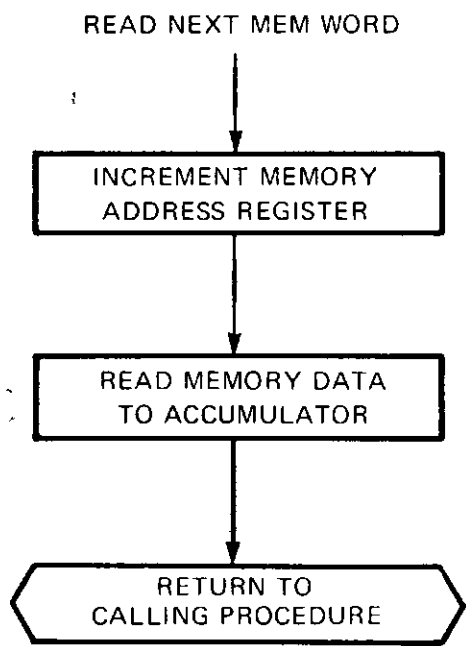

Figure 6-14 READ NEXT MEMORY WORD

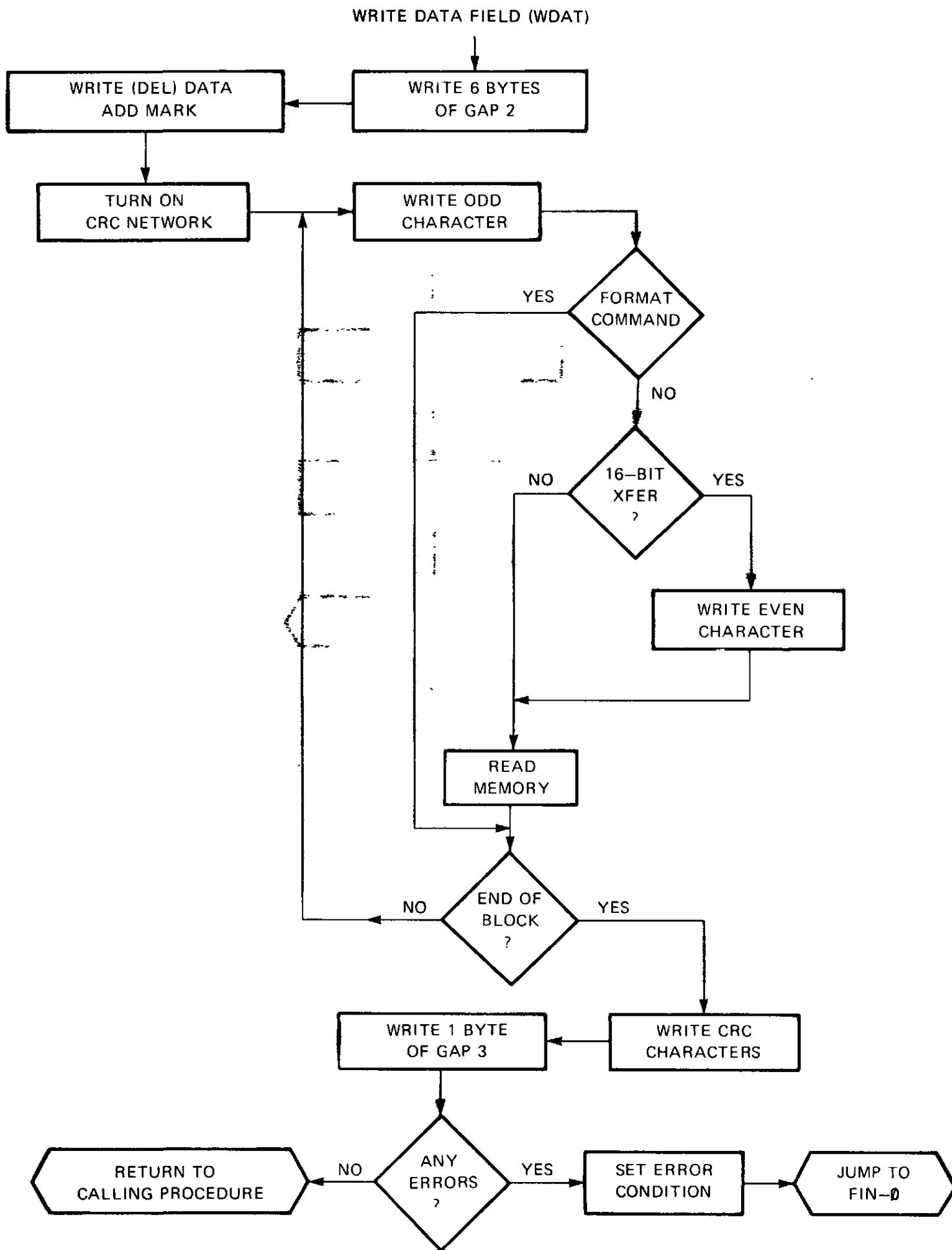

Figure 6-15 WRITE DATA FIELD

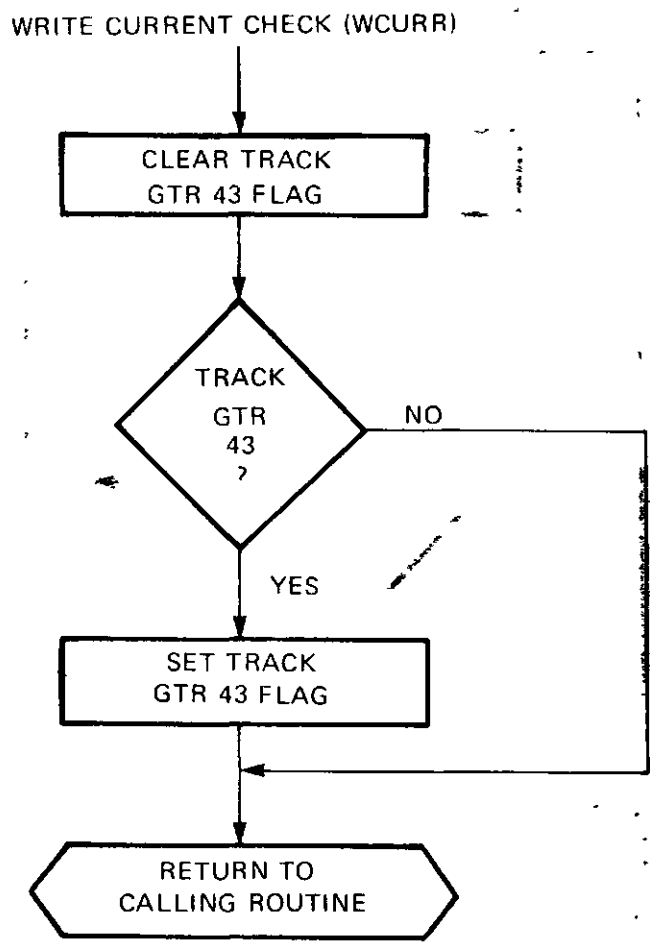

Figure 6-16 WRITE CURRENT CHECK

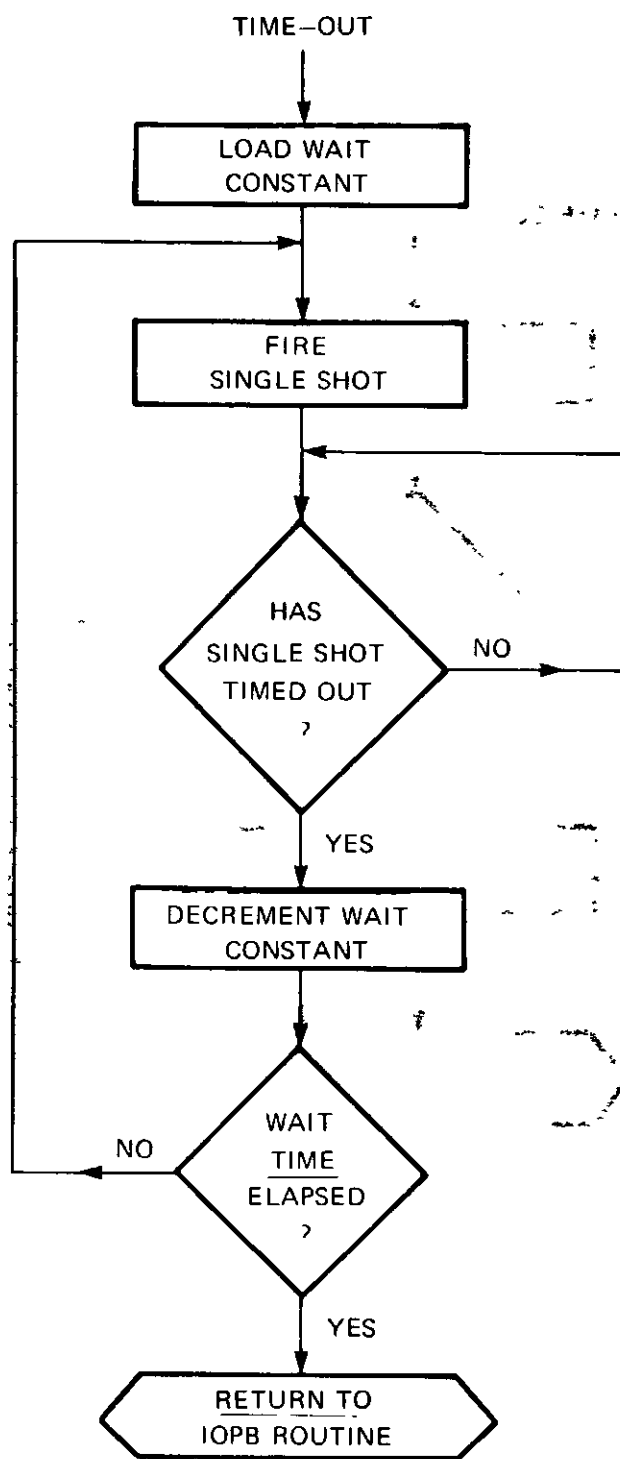

Figure 6-17 TIME-OUT

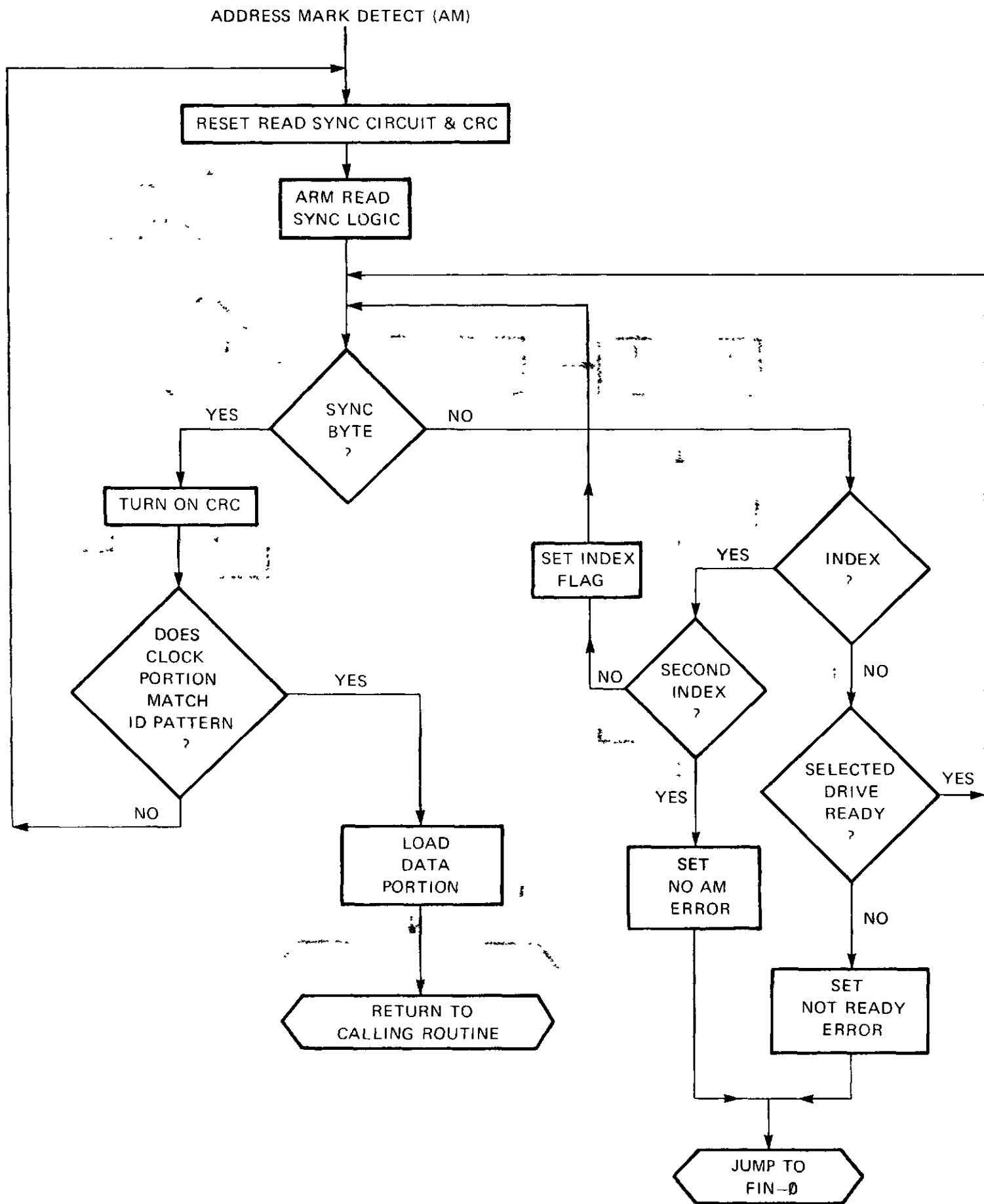

Figure 6-18 ADDRESS MARK DETECT

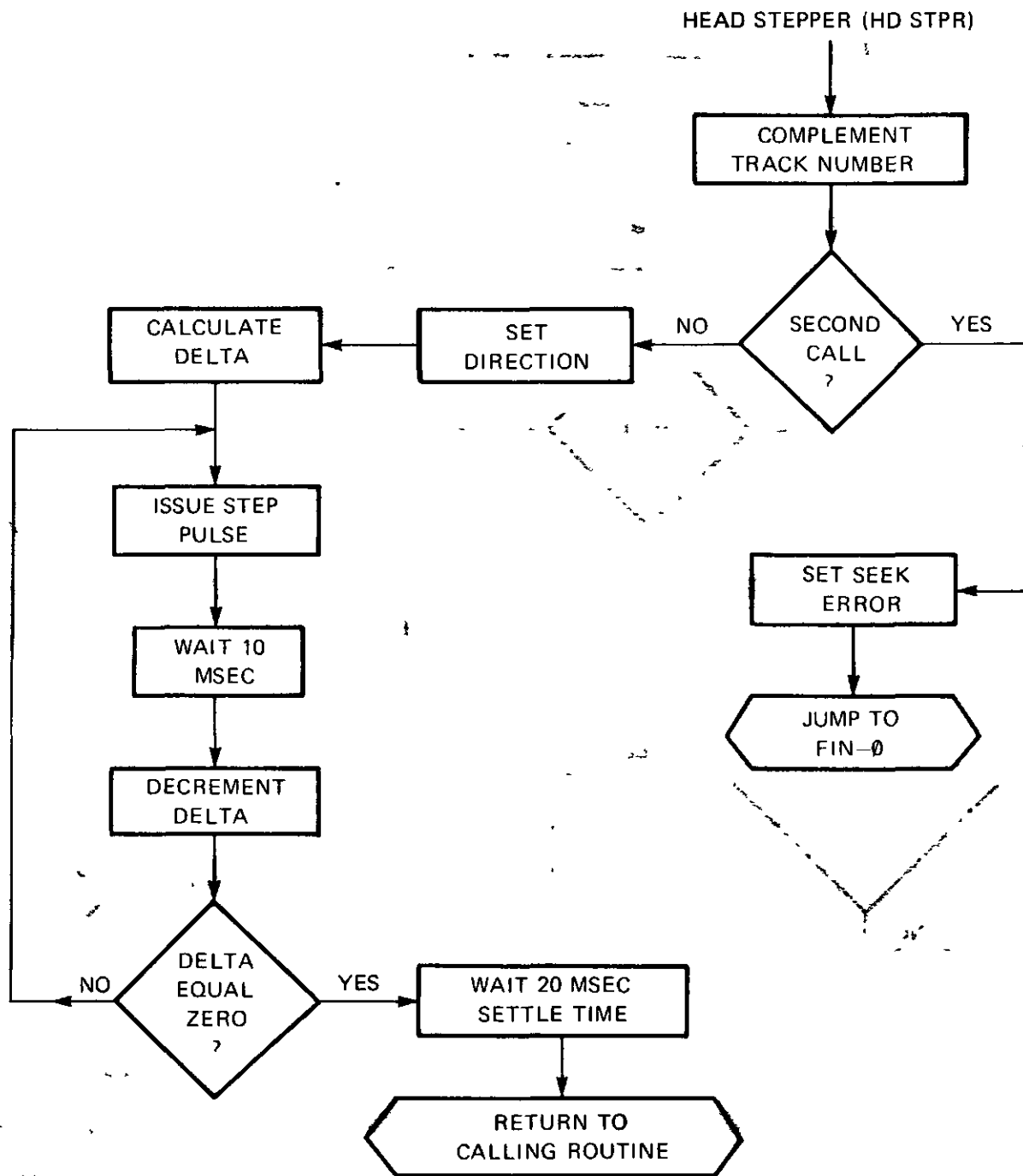

Figure 6-19 HEAD STEPPER

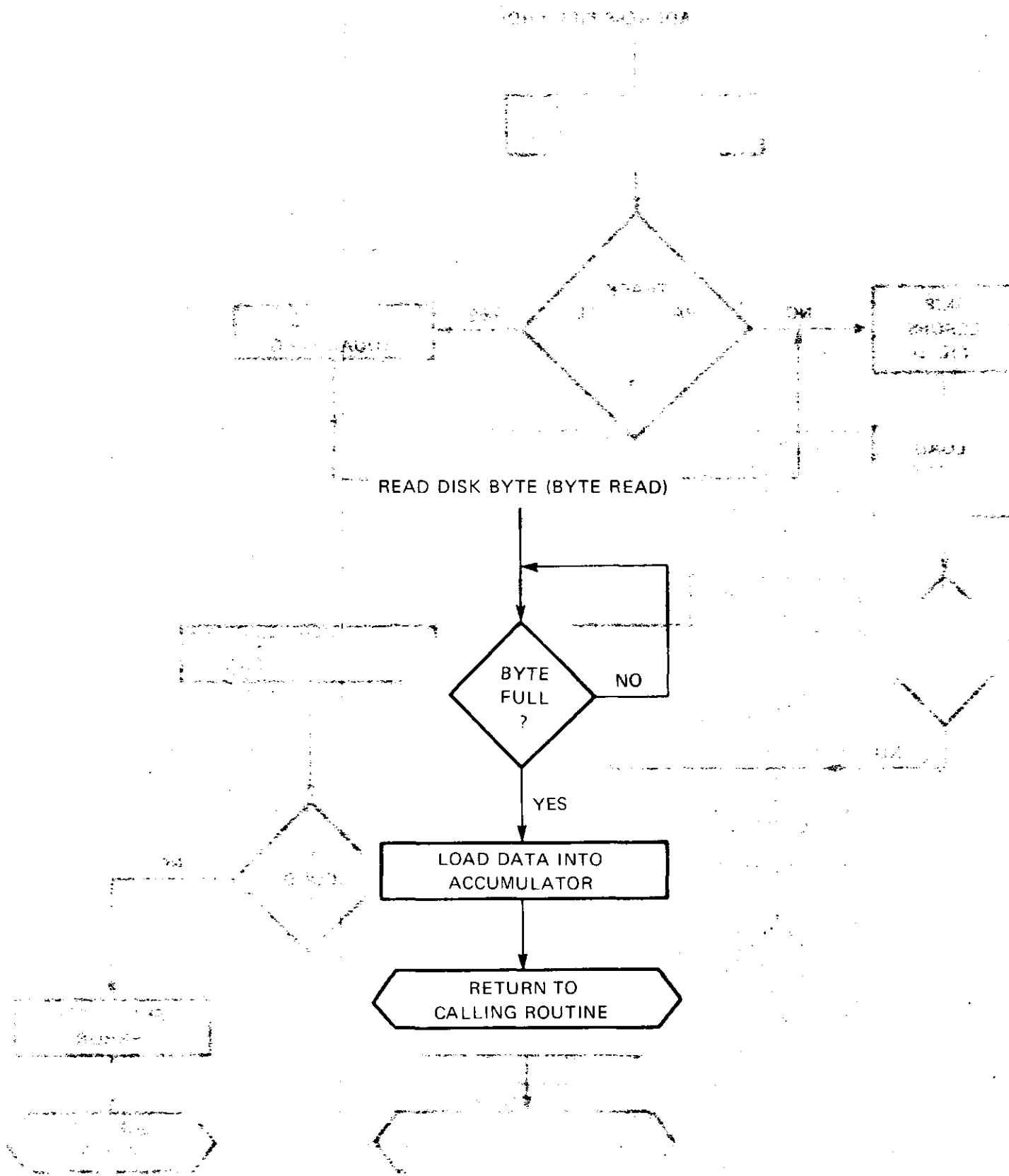

Figure 6-20 READ DISK BYTE

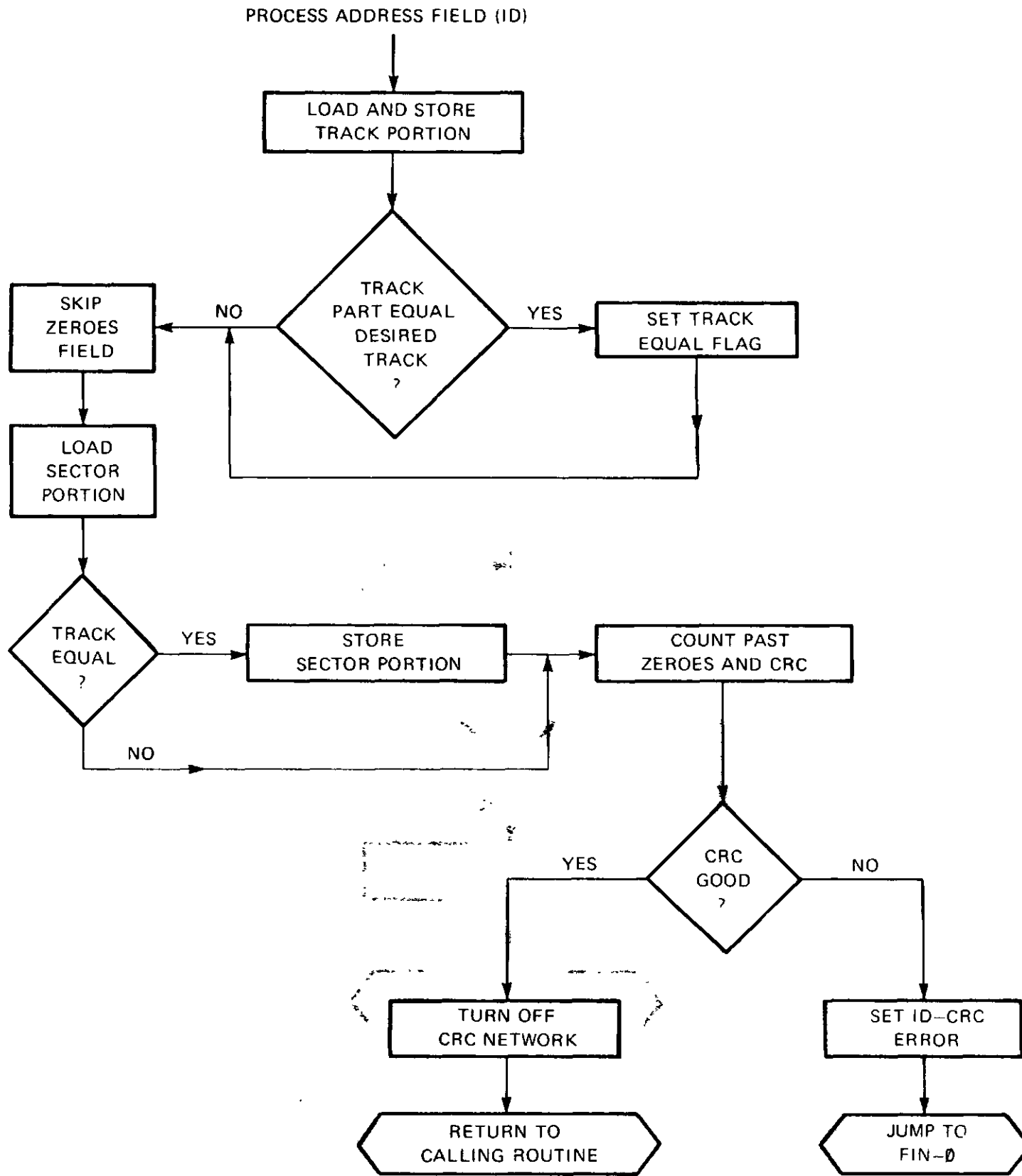

Figure 6-21 PROCESS ADDRESS FIELD

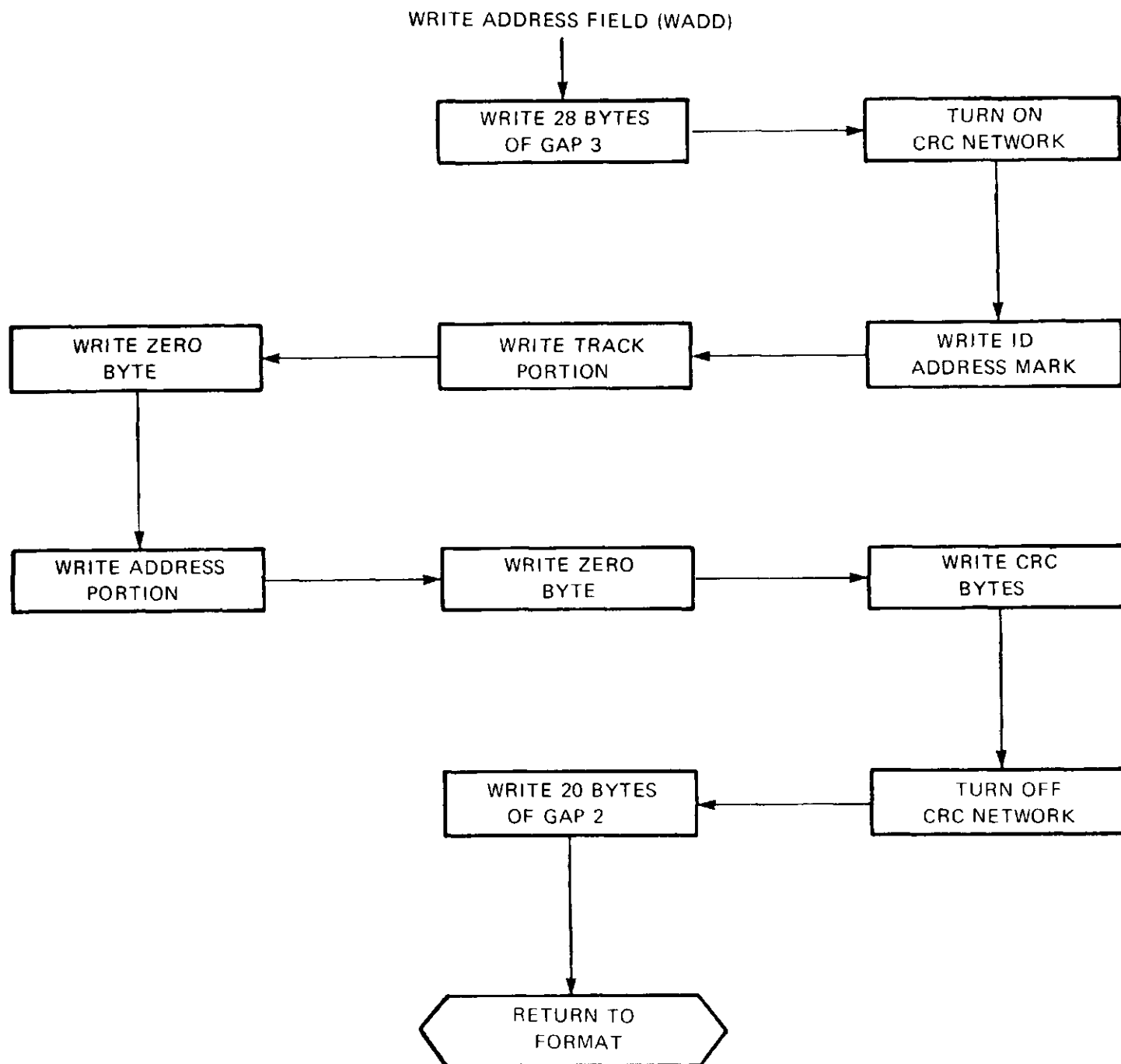

Figure 6-22 WRITE ADDRESS FIELD

)

•
•

()

)

()

•
•

()

— — — — —
— — — — —

— — — — —
— — — — —
— — — — —

— — — — —
— — — — —
— — — — —

— — — — —
— — — — —
— — — — —

— — — — —
— — — — —
— — — — —

— — — — —
— — — — —
— — — — —

— — — — —
— — — — —
— — — — —

— — — — —
— — — — —
— — — — —

CHAPTER 7

UTILIZATION

This chapter provides the necessary information to install and fully utilize the capabilities of the Diskette System. In installing the Diskette System, consider the following:

1. Environmental extremes
2. Mounting recommendations
3. Electrical connections
4. Base address selection
5. Interrupt level selection

The following sections of this chapter will deal with these considerations.

7.1 ENVIRONMENTAL EXTREMES

Temperature extremes can cause instability, or result in permanent damage to the circuits or the drive mechanisms. Ambient temperature must therefore be maintained within the limits of 50° to 100°F (10° – 38°C), 20% to 80% relative humidity with maximum wet bulb temperature of 80°F.

Exercise caution in locating the system, giving particular attention to radiant and conductive sources of heat. Remember that the system itself will contribute some heat to the environment (314 BTU/hour for each diskette drive). Provide adequate ventilation to permit the convective dissipation of heat from the system components.

7.2 MOUNTING RECOMMENDATIONS

Controller: The Channel Board and Interface Board (jointly referred to as the diskette controller) are to be inserted inside the INTELLEC System cabinet. Both boards are designed to plug directly into three standard PC-edge connectors. An 86-pin connector and a 60-pin connector are located on the bottom edge of the board and plug into the motherboard assembly. A 100-pin connector is on the opposite edge of the boards. The connectors serve as a mounting, as well as an electrical junction (see Section 7.3). Additional protection is provided by the guide slots in the INTELLEC System cabinet. The Channel and Interface Boards are each 12.00" x 6.75".

Before the controller boards are installed, the 60-pin dual auxiliary connector (1000515) must be installed in the INTELLEC System cabinet. The controller boards then plug in with the Interface Board in an ODD numbered slot and the Channel Board in an EVEN numbered slot.

Diskette Drive(s): The diskette drive(s) arrive in the diskette enclosure with their own power supply. No mounting is required.

7.3 ELECTRICAL CONNECTIONS

The Channel and Interface Boards each communicate with the INTELLEC System bus through a standard 86-pin double-sided PC edge connector (P1), 0.156" contact centers (see Figure 7-1). CONTROL DATA CORPORATION'S VPB01E43A00A1 is one suitable type of connector for P1. The two controller boards communicate with each other via a 60-pin, double-sided PC edge connector, 0.1" contact centers (see Figure 7-1). CDC97169001 is one suitable type of connector for P2. Both boards also include a 100-pin, double-sided PC edge connector (J1), 0.1" contact centers (see Figure 7-1). VIKING 3VH50/1JN5 is one suitable type of connector for J1. The Channel Board only uses its J1 connector as a means of accessing various test points on the board. The Interface Board, however, communicates with the diskette drive(s) via its J1 connector. The Interface Board's J1 connector also allows access to various test points. Pin allocations for each of the connectors on the Interface Board are provided in Section 4.3. The same information for the Channel Board is provided in Section 3.3.

The 'Floppy Disk Controller Cable' (supplied with the Diskette System) plugs into the J1 connector on the Interface Board. The other ends of the Controller Cable should be attached with the screws provided to the bulkhead on the back panel of the INTELLEC System cabinet. The 'Floppy Disk Peripheral Cable' should be attached to the drive enclosure and to J8 of the Controller Cable. To add an additional system drive enclosure (four drives total), plug a second 'Floppy Disk Peripheral Cable' onto the additional drive enclosure and to J10 of the Controller cable. All necessary cables are supplied with the equipment. Controller cable connector J8 interfaces to logical drives '0' and '1'. J10 interfaces to logical drives '2' and '3'.

The Diskette enclosure also includes an AC power cord which must be plugged into a convenient AC source.

CAUTION: The Diskette enclosure is shipped from the factory as either a 110V/60Hz system or 220V/50Hz system. Consult the shipping list and customer letter before plugging in the AC line cord. Using incorrect line voltage/frequency results in improper operation and potential damage to the diskette drives.

7.4 BASE ADDRESS SELECTION

The user must assign a base address to the Diskette Channel. The base address is defined by the five most significant bits of the eight-bit I/O port address. The three least significant bits, then, can be used to differentiate between eight input or eight output channel commands. When the CPU accesses the Diskette Channel by executing an I/O instruction the base address (BASE) is used to select the Diskette Channel, while the three low-order address bits select one of the channel commands, as described in Chapter 2.

A base address is assigned by opening or closing the five most significant switch positions of the S1 switch (S1 - 4, 5, 6, 7, 8) on the Channel Board (see sheet 1 of the Channel Board schematic in Section 3.3). When a switch position is closed (on) (tied to ground) it represents the assignment of a logical 0 address bit. When a position is open (off) (+5V), it represents a logical 1 selection.

The following sketch represents a base address selection of 78₁₆.

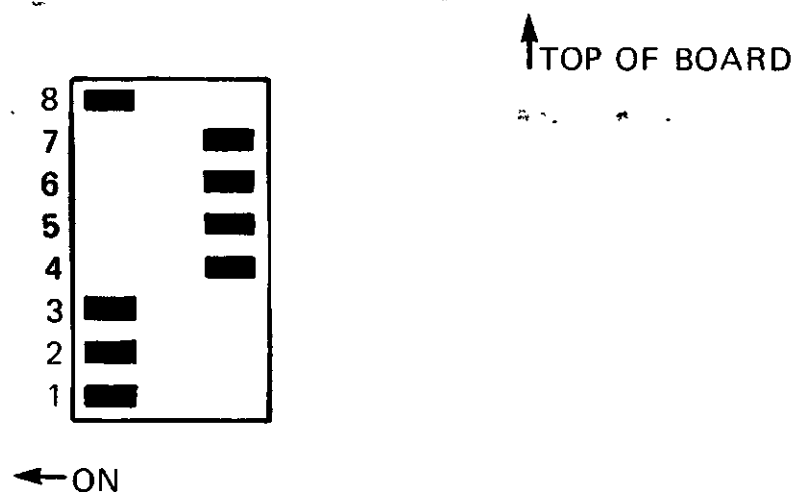

If the controller is to be used in conjunction with ISIS, the Diskette System software driver, the base address must be set to the value used with ISIS. This value is 78₁₆.

7.5 INTERRUPT LEVEL SELECTION

The user can assign the Diskette Channel's interrupt request line to any one of eight interrupt priority levels (INT0/ - INT7/) by moving the interrupt level select switch (S1) on the Interface Board to the desired position. This eight

position rotary switch is shown on sheet 3 of the Interface Board schematic in Section 4.3. The eight switch positions are associated with the following priority levels:

SWITCH POSITION	INTERRUPT PRIORITY LINE	RELATIVE PRIORITY (INTELLEC MDS SYSTEM)
1	INT0/	HIGHEST ↓ LOWEST
2	INT1/	
3	INT2/	
4	INT3/	
5	INT4/	
6	INT5/	
7	INT6/	
8	INT7/	

The following sketch shows the switch setting 3 corresponding to priority line INT2/.

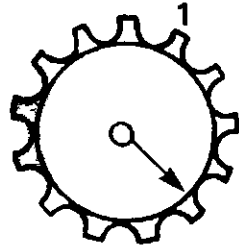

If the controller is to be used in conjunction with ISIS, the interrupt level section must be compatible with that used by ISIS. This value is switch setting 3.

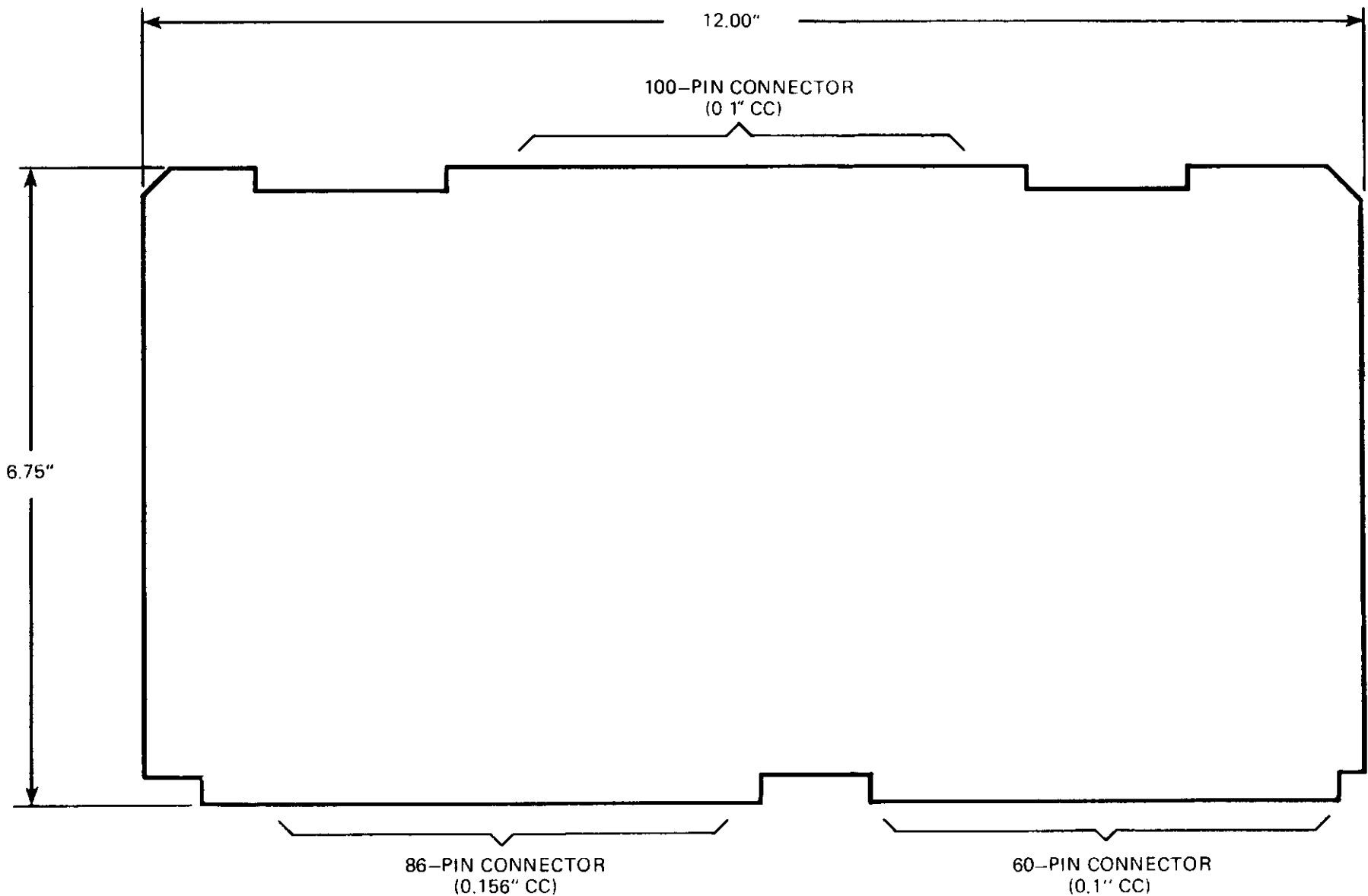
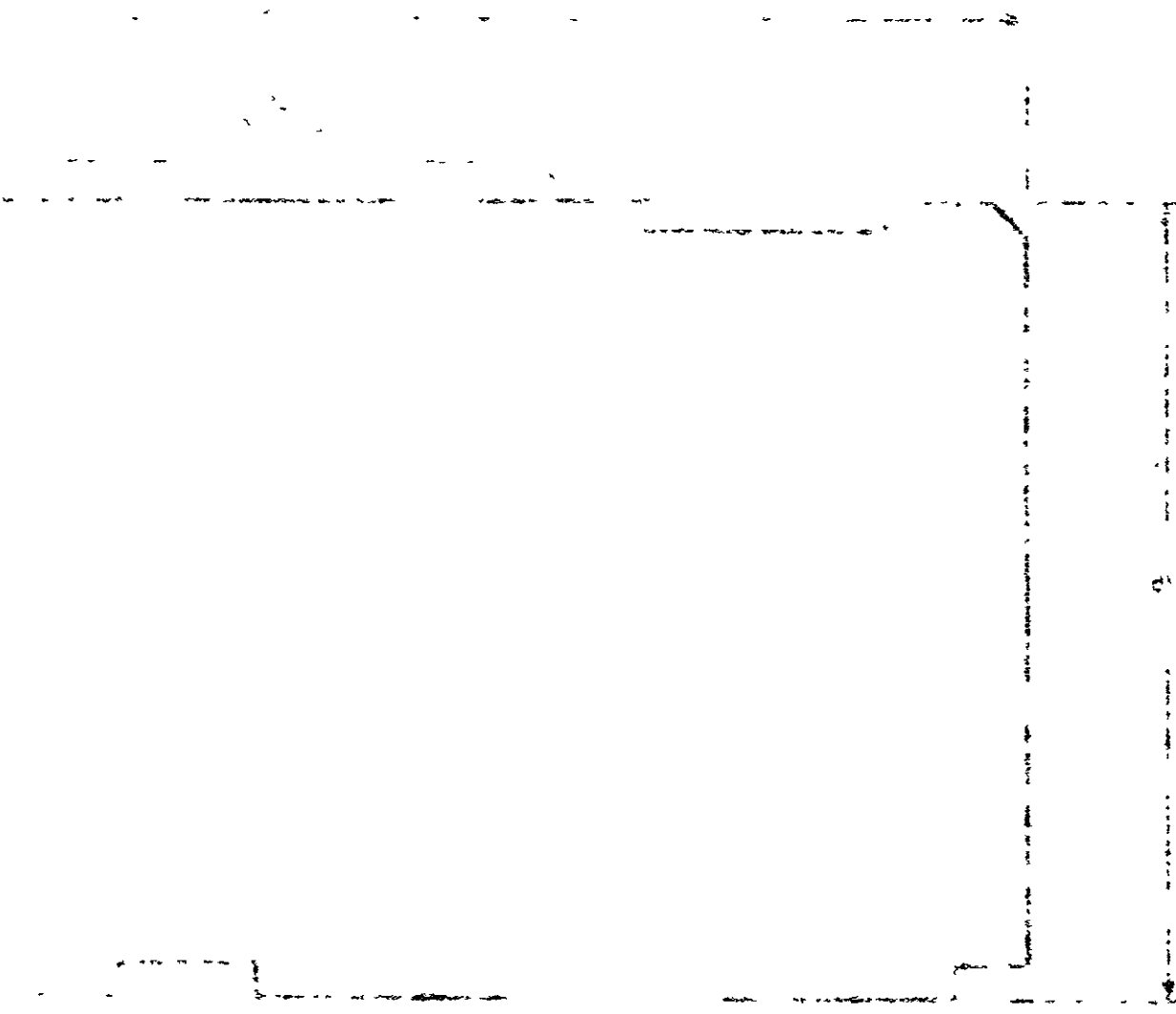
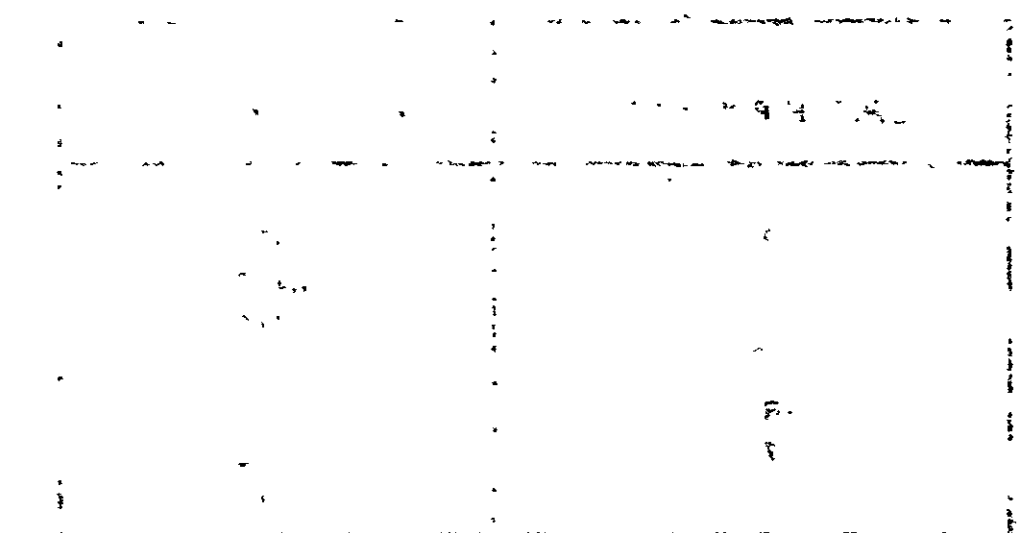

Figure 7-1 CONNECTORS ON THE CHANNEL AND INTERFACE BOARDS



THE ...



CHAPTER 8

OPERATING CHARACTERISTICS

This chapter provides AC and DC characteristics for all signals not internal to the Diskette System modules. These signals include the INTELLEC bus signals as well as the drive interface. Refer to the appropriate tables and figures for the desired rating.

8.1 AC CHARACTERISTICS

Tables 8-1 and 8-2 give the AC characteristics for the Diskette System boards.

Table 8-1 DISKETTE SYSTEM/INTELLEC BUS AC CHARACTERISTICS

PARAMETER	OVERALL MIN(NS) MAX(NS)	DESCRIPTION	REMARKS
t _{SAS}	50	Address Setup Time to I/O Command	Provided by Host CPU
t _{SDS}	0	Data Setup Time to I/O Command	Provided by Host CPU
t _{SAH}	0	Address Hold Time from I/O Command	Provided by Host CPU
t _{SDHW}	0	Data Hold Time from I/O Command	Provided by Host CPU
t _{SDHR}	25	Read Data Hold Time from I/O Command	Provided by Flexible Disc Controller (FDC)
t _{ACC}	Bus Timeout	I/O Access Time	Provided by FDC
t _{XKD}	7	XACK Delay from Read Data	Provided by FDC
t _{XKO}	30	XACK Hold Time from I/O Command	Provided by FDC
t _{BCY}	100	Bus Clock Cycle Time	Provided by CPU
t _{BW}	25	Bus Clock Low and High Periods	Provided by CPU
T _{CCY}	100	Common Clock Cycle Time	Provided by CPU
t _{CW}	25	Common Clock Low and High Periods	Provided by CPU
t _{DRO}	35	Bus Request Delay	
t _{DBY}	65	Bus Busy Turn on Delay	
t _{DBYF}	40	Bus Busy Turn off Delay	
t _{DBPN}	30	Priority Input Setup Time	
t _{DBPO}	20	BPRO/ Serial Delay from BPRN/	
t _{DB}	50	Busy to Address/Data Delay	

Table 8-1 DISKETTE OPERATING SYSTEM INTELLEC BUS AC CHARACTERISTICS (CONTINUED)

PARAMETER	OVERALL		DESCRIPTION	REMARKS
	MIN(NS)	MAX(NS)		
$t_{AS, DS}$	60		Address/Data Setup to Command	
t_{XKCO}	35	125	XACK to Command Turn Off	
t_{AH}	115		Address Hold Time	
t_{DHW}	125		Data Hold Time	
t_{DHR}	0		Read Data Hold Time	Provided by Memory Module (Slave)
t_{BS}	200		Bus Sample Delay Time	

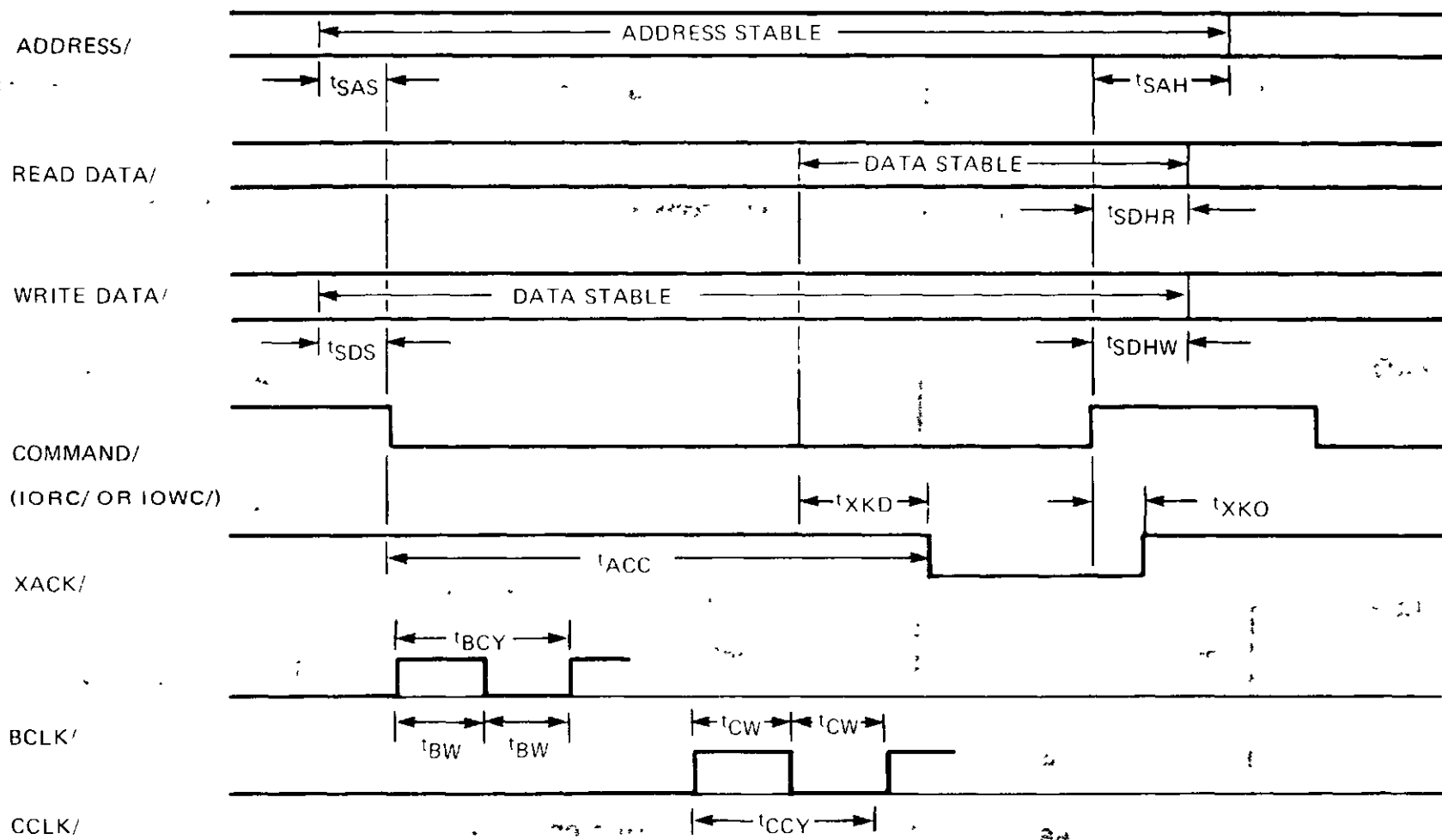

Figure 8-1 SLAVE COMMAND TIMING - FDCC

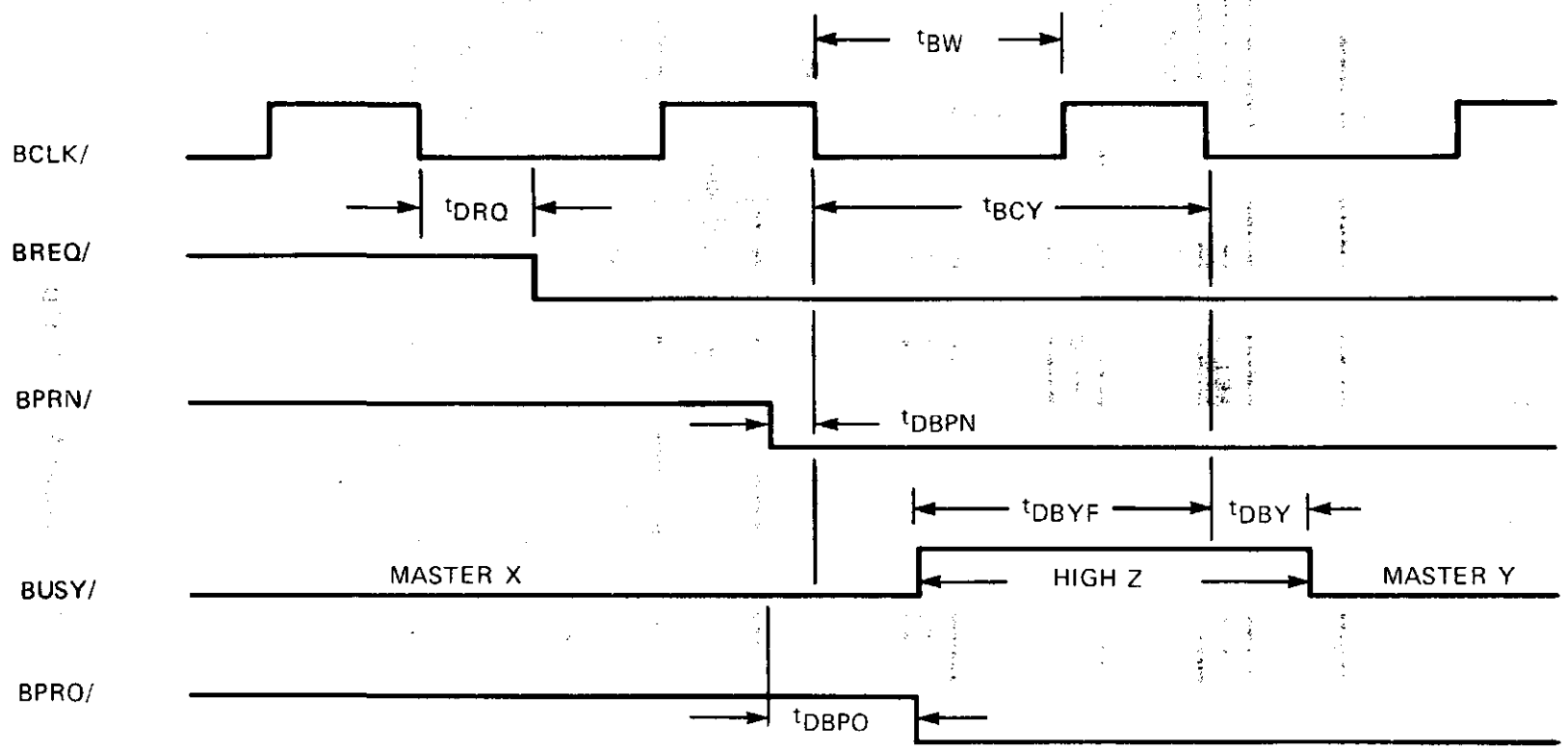

Figure 8-2 BUS EXCHANGE TIMING

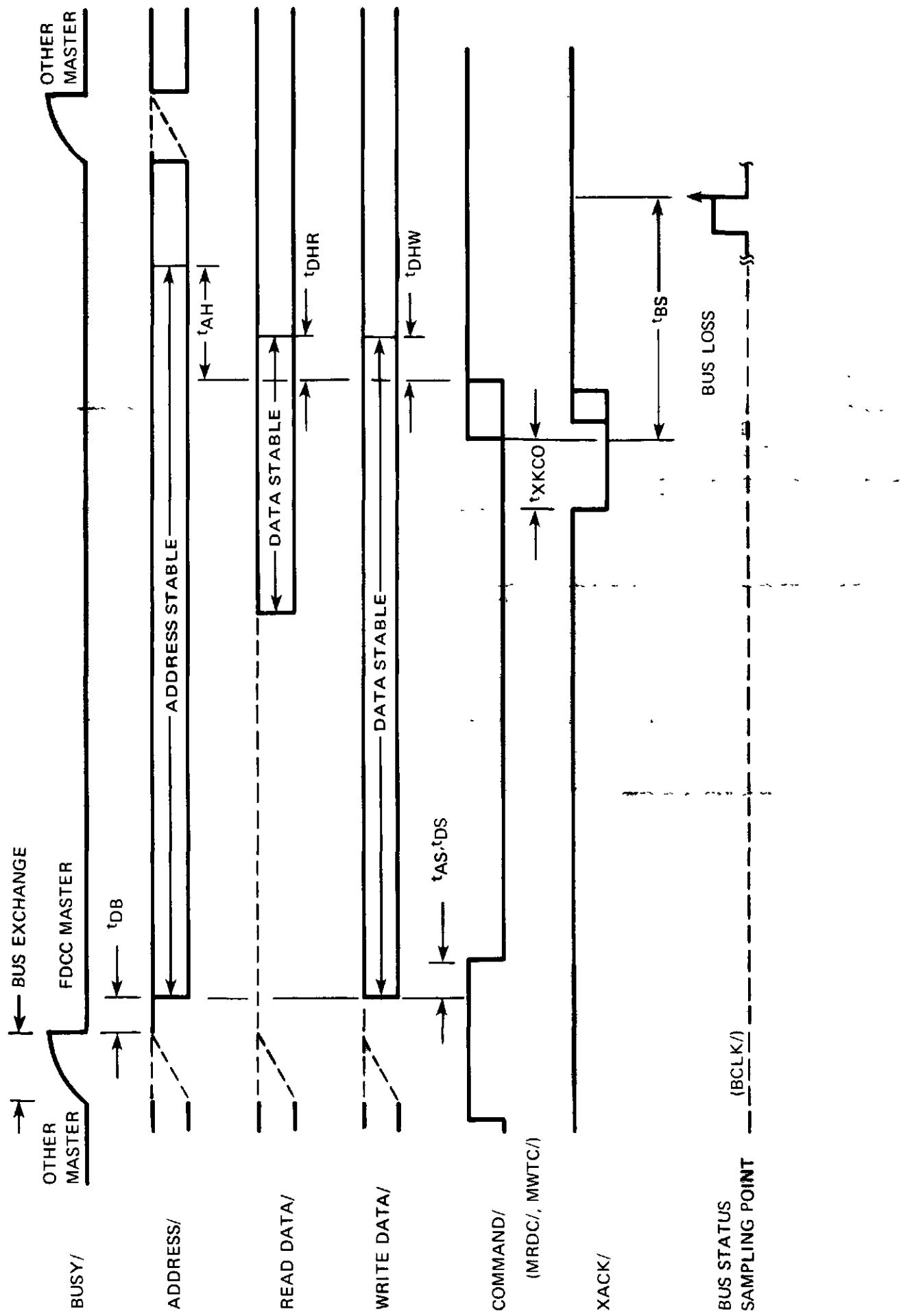

Figure 8-3 MASTER COMMAND TIMING



Table 8-2 DISKETTE SYSTEM/DRIVE INTERFACE AC CHARACTERISTICS

PARAMETER	OVERALL			DESCRIPTION
	MIN	TYP	MAX	
t _{SCYS}	8 msec	10 msec	12 msec	Step Cycle Time
t _{SPW}		10 usec		Step Pulse Width
t _{LSET}		60 msec		Settling Time – Select to Data
t _{SSET}		20 msec		Settling Time – Step to Data
t _{RDPW}	200 nsec	250 nsec	300 nsec	Read Data Pulse Width (Rd)
t _{CELL}		2 usec		Bit Cell Time
t _{WDPW}		250 nsec		Write Data Pulse Width (Wt)
t _{NXPW}		1.5 msec		Index Pulse Width
t _{NXCY}		166.7 msec		Index Cycle Time
t _{WFPW}	2 usec		2.8 usec	Write Fault Reset Pulse Width

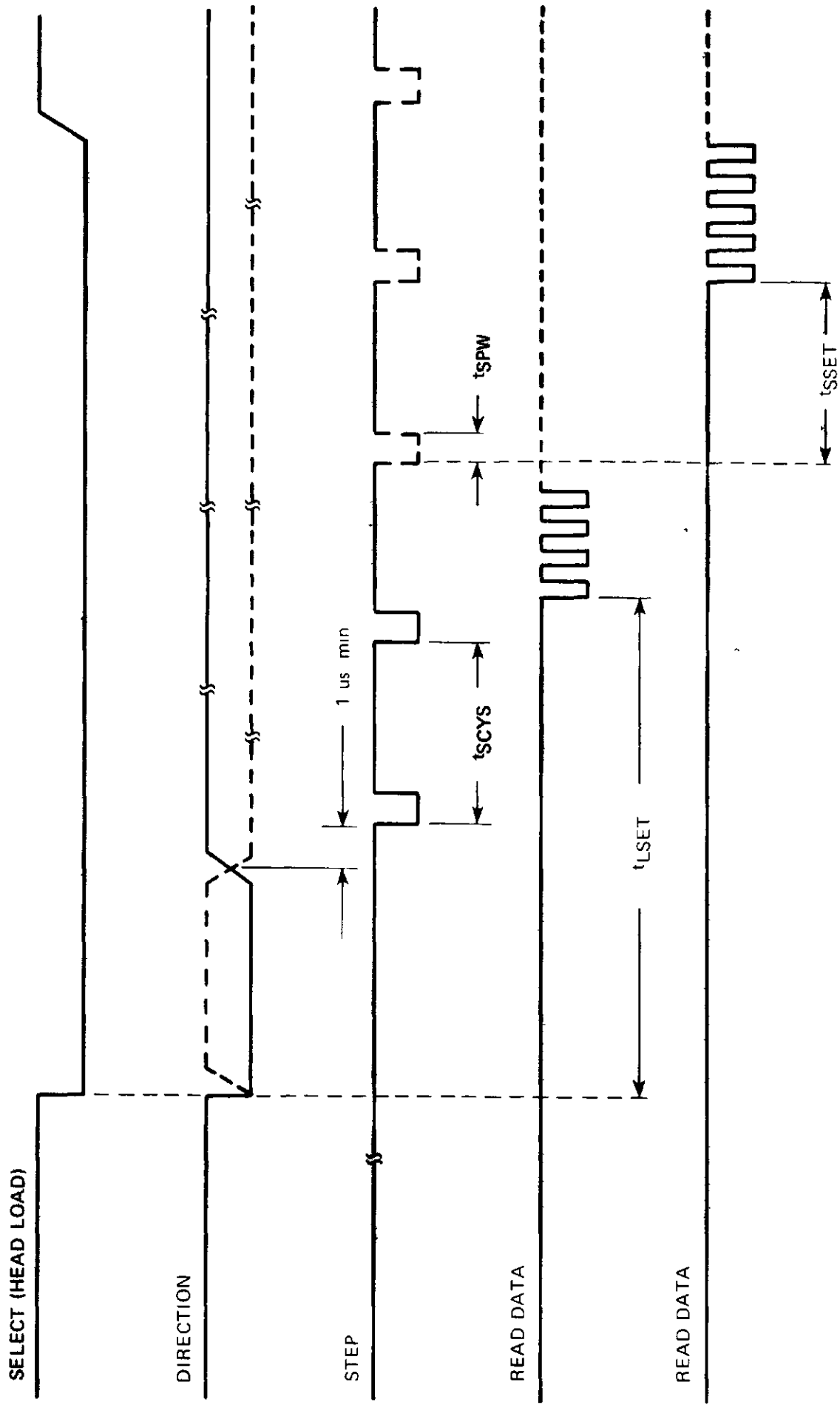

Figure 8-4 STEP/SETTLING TIMINGS



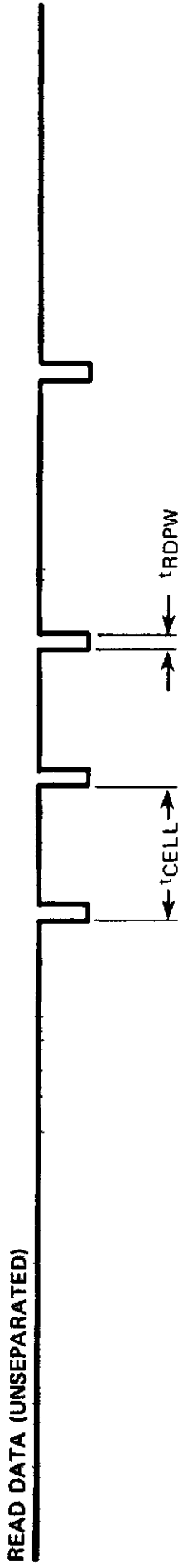

Figure 8-5 READ TIMING

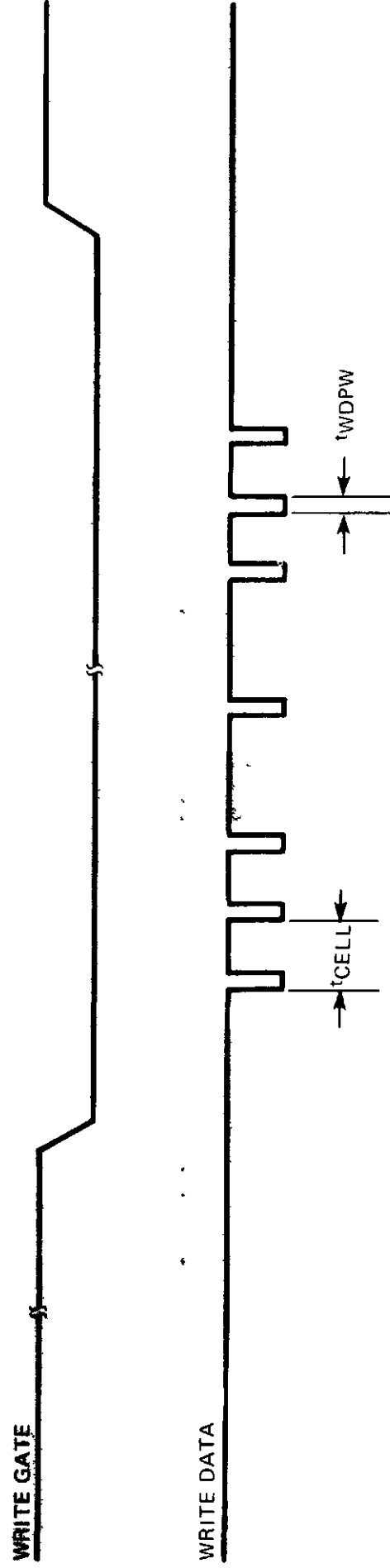

Figure 8-6 WRITE TIMING

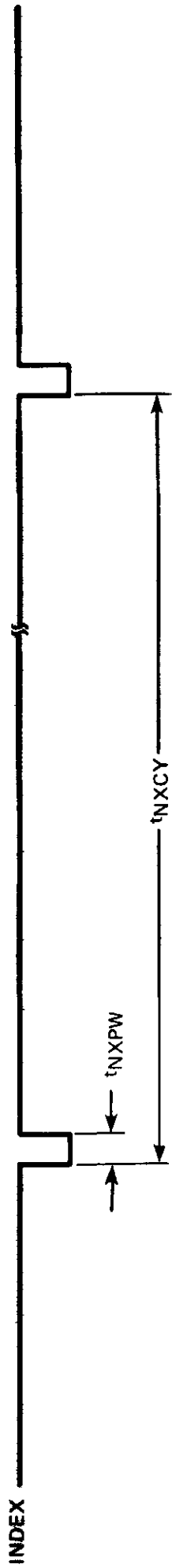

Figure 8-7 INDEX TIMING

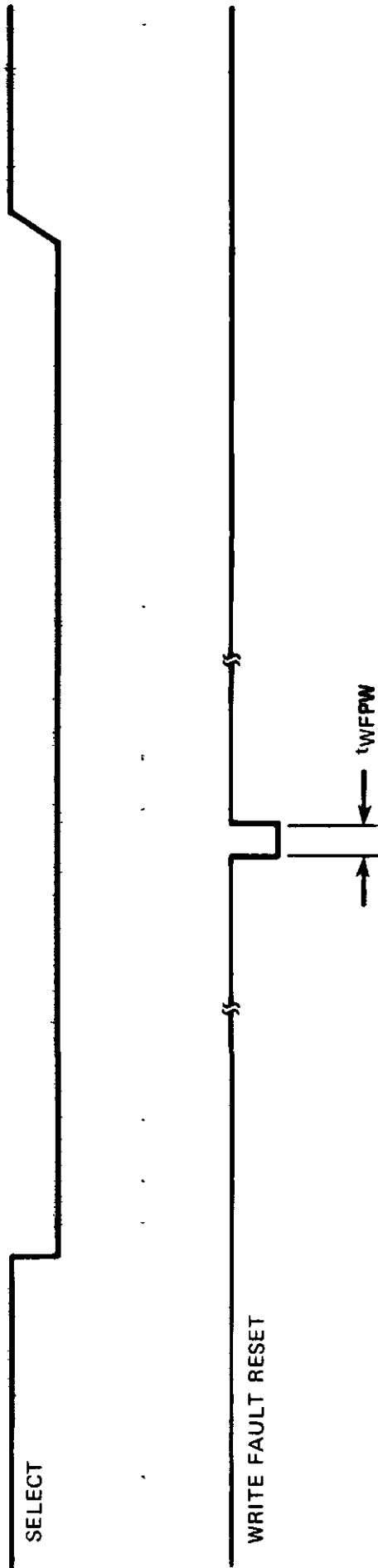

Figure 8-8 WRITE FAULT RESET TIMING

8.2 DC CHARACTERISTICS

The following two tables (8-3 and 8-4) give the DC characteristics for the Channel and Interface Boards. Both the INTELLEC bus and drive interface are included. The values are derived from manufacturers' specifications and calculated values if passive loading exists. Capacitance values are approximations.

Power requirements for the boards are as follows:

	V _{cc} (+5VDC±5%)		-10VDC	
	TYP	MAX	TYP	MAX
CHANNEL BOARD	3.75A	5.0A	—	—
INTERFACE BOARD	1.5A	2.5A	100mA	200mA
TOTAL	5.25A	7.5A	100mA	200mA

Table 8-3 DISKETTE OPERATING SYSTEM DC CHARACTERISTICS (INTELLEC BUS)

SIGNAL	SYMBOL	PARAMETER DESCRIPTION	TEST CONDITION	PARAMETER		
				MIN	MAX	UNITS
ADRF/-ADR8/	V _{OL}	Output Low Voltage	I _{OL} =10mA		.45	V
	V _{OH}	Output High Voltage	I _{OH} =-1mA	2.4		V
	C	Capacitive Load			15	pf
ADR7/ - ADR0/	V _{OL}	Output Low Voltage	I _{OL} =15mA		.45	V
	V _{OH}	Output High Voltage	I _{OH} =-1mA	3.65		V
	V _{IL}	Input Low Voltage			.8	V
	V _{IH}	Input High Voltage		2		V
	I _{IL}	Input Current at V _{IL}	V _{IL} = .4V		-1.6	mA
	I _{IH}	Input Current at V _{IH}	V _{IH} =2.4V		40	uA
	C	Capacitive Load			15	pf
DATF/ - DAT4/	V _{OL}	Output Low Voltage	I _{OL} =15mA		.45	V
	V _{OH}	Output High Voltage	I _{OH} =-1mA	3.65		V
	V _{IL}	Input Low Voltage			.85	V
	V _{IH}	Input High Voltage		2		V
	I _{IL}	Input Current at V _{IL}	V _{IL} = .45V		-.25	mA
	I _{IH}	Input Current at V _{IH}	V _{IH} =5.25V		10	uA
	C	Capacitive Load			15	pf
DAT3/ - DAT0/	V _{OL}	Output Low Voltage	I _{OL} =15mA		.45	V
	V _{OH}	Output High Voltage	I _{OH} =-1mA	3.65		V
	V _{IL}	Input Low Voltage			.85	V
	V _{IH}	Input High Voltage		2		V

TABLE 8-3 (CONTINUED)

SIGNAL	SYMBOL	PARAMETER DESCRIPTION	TEST CONDITION	PARAMETER		
				MIN	MAX	UNITS
BCLK/ CCLK/	I_{IL}	Input Current at V_{IL}	$V_{IL} = .45V$		-.25	mA
	I_{IH}	Input Current at V_{IH}	$V_{IH} = 5.25V$		10	uA
	C	Capacitive Load			15	pf
	V_{IL}	Input Low Voltage			.8	V
	V_{IH}	Input High Voltage		2		V
	I_{IL}	Input Current at V_{IL}	$V_{IL} = .4V$		-2	mA
BPRN/	I_{IH}	Input Current at V_{IH}	$V_{IH} = 2.4V$		50	uA
	C	Capacitive Load			15	pf
	V_{IL}	Input Low Voltage			.8	V
	V_{IH}	Input High Voltage		2		V
	I_{IL}	Input Current at V_{IL}	$V_{IL} = .4V$		-3.2	mA
	I_{IH}	Input Current at V_{IH}	$V_{IH} = 2.4V$		80	uA
IORC/, IOWC/ INIT/	C	Capacitive Load			15	pf
	V_{IL}	Input Low Voltage			.8	V
	V_{IH}	Input High Voltage		2		V
	I_{IL}	Input Current at V_{IL}	$V_{IL} = .4V$		-1.6	mA
	I_{IH}	Input Current at V_{IH}	$V_{IH} = 2.4V$		40	uA
	C	Capacitive Load			15	pf
XACK/	V_{OL}	Output Low Voltage	$I_{OL} = 16mA$.4	V
	V_{OH}	Output High Voltage	$I_{OH} = -5.2mA$	2.4		V
	V_{IL}	Input Low Voltage			.8	V
	V_{IH}	Input High Voltage		2		V
	I_{IL}	Input Current at V_{IL}	$V_{IL} = .4V$		-1.6	mA
	I_{IH}	Input Current at V_{IH}	$V_{IH} = 2.4V$		40	uA
	I_{LL}	Input Leakage Low	High Z $V_0 = 2.4V$		-40	uA
	I_{LH}	Input Leakage High	High Z $V_0 = .4V$		40	uA
	C	Capacitive Load			15	pf
	BPRO/	V_{OL}	Output Low Voltage	$I_{OL} = 3.2mA$.45
V_{OH}		Output High Voltage	$I_{OH} = 400uA$	2.4		V
C		Capacitive Load			15	pf
BREQ	V_{OL}	Output Low Voltage	$I_{OL} = 20mA$.45	V
	V_{OH}	Output High Voltage	$I_{OH} = 400uA$	2.4		V
	C	Capacitive Load			15	pf

)

.

,

)

)

)

,

,

)

Table 8-4 FDCC DC CHARACTERISTICS (DRIVE/DISPLAY INTERFACE)

SIGNAL	SYMBOL	PARAMETER DESCRIPTION	TEST CONDITION	PARAMETER		
				MIN	MAX	UNITS
SEL0/, SEL1/ SEL2/, SEL3/ WRT DAT/ WRT GT/ STEP/ DIR/ WRT FLT RESET/ TRACK GT 43/	V _{OL} I _{OH} C	Output Low Voltage Output High Leakage Capacitive Load	I _{OL} =48mA Open Collector Off V _{OH} =5.5V		.4 250 15	V uA pf
READY 0/ READY 1/ SEP DATA/ SEP CLOCK/ TRACK 0/ INDEX/ WRT FLT/ WPROT/	V _{IL} V _{IH} I _{IL} I _{IH} C	Input Low Voltage Input High Voltage Input Current at V _{IL} Input Current at V _{IH} Capacitive Load	V _{IL} = .8 V _{IH} =3.0	3.0	.8 -26 10 15	V V mA (2) mA (1) pf
LED0/ LED1/	V _{OL} V _{OH} C	Output Low Voltage Output High Voltage Capacitive Load	I _{OL} =16mA I _{OH} =400ua	2.4	.4 15	V V pf

- (1) Includes 9.1mA due to 220/330Ω pull-up/pull-down.
- (2) Includes 25mA due to 220/330Ω pull-up/pull-down.

C

.

.

C

C

C

.

.

C