

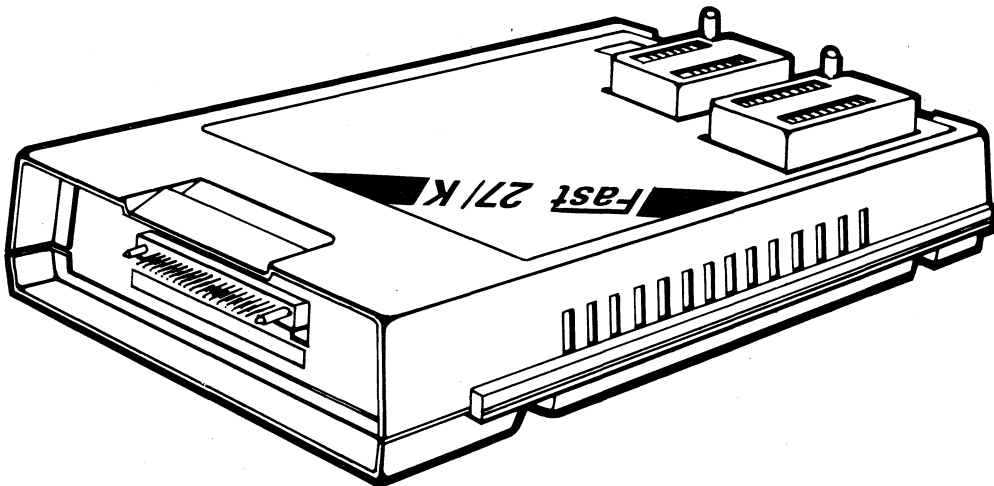

# iUP-FAST 27/K PERSONALITY MODULE USER'S GUIDE

---





**iUP-FAST 27/K  
PERSONALITY MODULE  
USER'S GUIDE**

Order Number: 164376-003

Copyright 1984,1985, Intel Corporation

Intel Corporation, 3065 Bowers Avenue, Santa Clara, California 95051

**CAUTION**

This equipment generates, uses, and can radiate radio frequency energy and if not installed and used in accordance with the instruction manual, may cause interference to radio communications. It has been tested and found to comply with the limits for a Class A Computing Device pursuant to Subpart J of Part 15 of FCC rules, which are designed to provide reasonable protection against such interference when operated in a commercial environment. Operation of this equipment in a residential area is likely to cause interference in which case the user, at his own expense, will be required to take whatever measures may be required to correct the interference.

Additional copies of this manual or other Intel literature may be obtained from:

Literature Department  
Intel Corporation  
3065 Bowers Avenue  
Santa Clara, CA 95051

The information in this document is subject to change without notice.

Intel Corporation makes no warranty of any kind with regard to this material, including, but not limited to, the implied warranties of merchantability and fitness for a particular purpose. Intel Corporation assumes no responsibility for any errors that may appear in this document. Intel Corporation makes no commitment to update nor to keep current the information contained in this document.

Intel Corporation assumes no responsibility for the use of any circuitry other than circuitry embodied in an Intel product. No other circuit patent licenses are implied.

Intel software products are copyrighted by and shall remain the property of Intel Corporation. Use, duplication or disclosure is subject to restrictions stated in Intel's software license, or as defined in ASPR 7-104.9(a)(9).

No part of this document may be copied or reproduced in any form or by any means without prior written consent of Intel Corporation.

Intel Corporation makes no warranty for the use of its products and assumes no responsibility for any errors which may appear in this document nor does it make a commitment to update the information contained herein.

Intel retains the right to make changes to these specifications at any time, without notice.

Contact your local sales office to obtain the latest specifications before placing your order.

The following are trademarks of Intel Corporation and its affiliates and may be used only to identify Intel products:

- |                    |                         |                 |               |
|--------------------|-------------------------|-----------------|---------------|
| BITBUS             | i <sub>m</sub>          | iRMX            | Plug-A-Bubble |
| COMMputer          | iMDDX                   | iSBC            | PROMPT        |
| CREDIT             | iMMX                    | iSBX            | Pronware      |
| Data Pipeline      | Insite                  | iSDM            | QueX          |
| Genius             | Intel                   | iSXM            | QUEST         |
| Δ                  | intel                   | Library Manager | Ripplemode    |
| i                  | intelBOS                | MCS             | RMX/80        |
| i <sup>2</sup> ICE | Intelelevision          | Megachassis     | RUPI          |
| ICE                | intelligent Identifier  | MICROMAINFRAME  | Seamless      |
| iCS                | intelligent Programming | MULTIBUS        | SLD           |
| iDBP               | Inteltec                | MULTICHANNEL    | SYSTEM 2000   |
| iDIS               | Intellink               | MULTIMODULE     | UPI           |
| iLBX               | iOSP                    | OpenNET         |               |
|                    | iPDS                    |                 |               |

MDS is an ordering code only and is not used as a product name or trademark. MDS® is a registered trademark of Mohawk Data Sciences Corporation.

\*MULTIBUS is a patented Intel bus.

Copyright 1985, Intel Corporation

REV.	REVISION HISTORY	DATE
-001	Original Issue.	2/84
-002	Upgrade to support the 27C64, 27128A, 27512, and 27513 EPROMs and the 2817A E <sup>2</sup> PROM.	9/84
-003	Upgrade to support the 87C64 and 27C256 EPROMs and the 27916 KEPROM.	3/85





The iUP-Fast 27/K personality module is one of a series of personality modules used to adapt the Intel iUP-200A/201A universal programmer and the Intel personal development system (iPDS™) to a particular family of PROM devices. You cannot use the personality module without a universal programmer or an iPDS system.

## NOTE

You must have one of the following configurations to use the Fast 27/K personality module:

iPDS system	Intel PROM programming software (iPPS-iPDS), version 1.4 or later iPDS-140 EMV/PROM adapter option
universal programmer:	
on-line	Intel PROM programming software (iPPS), version 1.4 or later model 200A/201A
off-line	model 201A

You can easily update your iUP-200/201 universal programmer to an iUP-200A/201A universal programmer with the iUP-200/201 U1 upgrade kit.

This manual supports the U2 upgrade to the iUP-Fast 27/K personality module. The U2 upgrade adds programming support for the 27C64, 87C64, 27128A, 27C256, 27512, and 27513 EPROMs, the 27916 KEPROM, and the 2817A E<sup>2</sup>PROM, while maintaining support for the 2764, 2764A, 27128, and the 27256 EPROMs.

The following publications contain additional information on using the personality modules.

- *iUP-200A/201A Universal Programmer User's Guide*, order number 164852  
This manual describes universal programmer operation.
- *iPDS™ Personal Development System User's Guide*, order number 162606  
This manual describes iPDS system operation.
- *iPPS PROM Programmer Software User's Guide*, order number 164861  
This manual describes the PROM programming software used for on-line operation of the universal programmer and the iPDS system.
- *Memory Components Handbook*, order number 210830  
This handbook contains all application notes, article reprints, data sheets, and other design information on RAMs, DRAMs, EPROMs, E<sup>2</sup>PROMs, and bubble memories.



## SERVICE INFORMATION

Intel customer engineers furnish the best service for your Intel products. These trained professionals provide the prompt, efficient on-site installation, preventive maintenance, and corrective maintenance required to keep your equipment in the best operating condition.

Intel customer engineers provide service through a prepaid service contract or on an hourly basis. Contact your local Intel sales office for further information.

When an Intel customer engineer is not available, contact the Intel product service center.

United States customers can obtain Intel service and repair assistance by contacting the Intel product service center in their area. Customers outside the United States should contact their Intel sales office or authorized distributor for service information and repair assistance.

Have the following information available before calling the product service center:

- The date you received the product.
- The complete part number of the product (including dash number). On boards, this number is usually silk-screened onto the board. On other products, it is usually stamped on a label.
- The serial number of the product. On boards, this number is usually stamped on the board. On other products, the serial number is usually stamped on a label mounted on the outside of the chassis.
- Your shipping and billing address.
- A purchase order number (for billing) if your Intel product warranty has expired.
- Any extended warranty agreements that apply.

Contact the Intel product service center using the following telephone numbers:

Western Region: (602) 869-4951  
Midwest Region: (602) 869-4392  
Eastern Region: (602) 869-4045  
International: (602) 869-4862  
TWX: (910) 952-1330

Always contact the product service center before returning a product to Intel for repair. Product service center personnel will give you a repair authorization number, shipping instructions, and other information to ensure fast, efficient service. If you are returning the product because of shipping damage or if the product is out of warranty, you must have a purchase order before Intel can start repairs.

If available, use the original factory packaging when returning a product to the Intel product service center. If the original packaging material is not available, wrap the product in a cushioning material such as Air Cap SD-240, manufactured by the Sealed Air Corporation, Hawthorne, NJ. Securely enclose the product in a heavy-duty corrugated shipping carton, mark it "FRAGILE," and ship it to the address specified by product service center personnel.





## CAUTIONS

The following cautions appear in this user's guide.

	PAGE
<b>CAUTION</b>	
Do not switch the universal programmer's or iPDS system's power on or off when a PROM device is installed in a socket of the personality module. Damage to the PROM device may result.	5
<b>CAUTION</b>	
Do not power on the system until you have read the powering on section in the <i>iUP-200A/201A Universal Programmer User's Guide</i> or the <i>iPDS™ Personal Development System User's Guide</i> .	5
<b>CAUTION</b>	
The orientation mark on one end of the PROM device must be toward the top of the socket. If a device is not oriented properly, it cannot be programmed and it may be damaged.	6





# CONTENTS

	<b>PAGE</b>
General Description .....	1
Applicable PROM Devices .....	2
iUP-Fast 27/K Sockets .....	3
Program Socket .....	3
Master Socket .....	3
iUP-Fast 27/K Indicators .....	3
Unpackaging and Inspection .....	4
Installation in the Universal Programmer or iPDS™ System .....	5
PROM Device Installation .....	5

## FIGURES

<b>FIGURE</b>	<b>TITLE</b>	<b>PAGE</b>
1	iUP-Fast 27/K Personality Module .....	1
2	iUP-Fast 27/K Personality Module Indicators .....	4
3	Installation in the Universal Programmer .....	6
4	Installation in the iPDS™ Chassis .....	7
5	PROM Device Installation .....	8

## TABLES

<b>TABLE</b>	<b>TITLE</b>	<b>PAGE</b>
1	iUP-Fast 27/K PROM Device Support .....	2
2	27513 Page Addresses .....	2





# iUP-FAST 27K PERSONALITY MODULE

## GENERAL DESCRIPTION

The iUP-Fast 27/K personality module (shown in Figure 1) plugs into a compatible Intel PROM programmer (the iUP-200A/201A universal programmer or the iPDS™ system) and adapts it for programming a family of PROM devices.

The iUP-Fast 27/K personality module is 7.75 inches deep by 5.5 inches wide by 2.0 inches high. It contains two 28-pin sockets, a hexadecimal display (0 through F), and a red LED that indicates when power is being applied to the socket(s). The program socket holds the device being programmed. The master socket is used by the module only in special instances while the universal programmer is in off-line mode. The hexadecimal display shows the PROM device type selected.

## NOTE

You can use the iUP-201A universal programmer in either on-line mode or off-line mode. You can use the iUP-200A universal programmer or the iPDS system in on-line mode only.

The Fast 27/K personality module uses the intelligent Identifier™ to verify that the PROM device in the program/master socket matches the device type selected. The operation continues if the type selected matches the type installed.

If the PROM device identification is invalid, the device is treated as if it were the type selected. In some cases, if the identification is recognized as one supported by the Fast 27/K personality module but does not match the type selected, the error message WRONG DEVICE SELECTED is displayed.

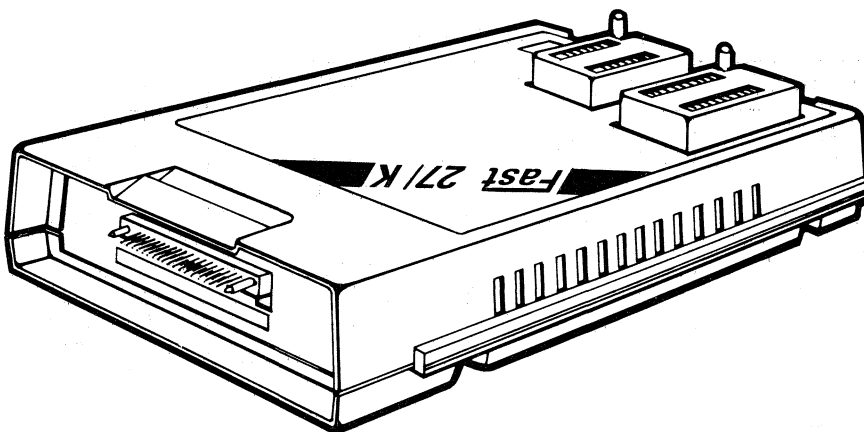

0150

Figure 1 iUP-Fast 27/K Personality Module

## APPLICABLE PROM DEVICES

The iUP-Fast 27/K personality module (with upgrade kits) provides support for several different PROM devices. Table 1 shows the PROM devices supported by the iUP-Fast 27/K personality module.

The 27513 EPROM is a 512K-byte design featuring paged addressing (four selectable pages of 16K by 8 bits). It brings software carrier capacity to microcontroller and 8-bit microprocessor architectures that are limited to 64K-byte total memory addressing.

The 27513's pages are numbered 0 through 3. Table 2 shows the addresses in the universal programmer or iPDS system that correspond to each page. The 27513 data sheet contains additional programming information.

The following example illustrates using the iPPS PROM programming software to program the 27513 with the contents of a file named EXAMPL which resides on drive 1. The starting address of 8000 indicates that the contents of the file are copied to the 27513 beginning at address 0 on page 2.

```
PPS> COPY :F1:EXAMPL TO PROM(8000)
```

### NOTE

The 27513 (page mode 512K-bit) EPROM is supported only in on-line mode.

Refer to the SHIFT-LOCK 4 command in the *iUP-200A/201A Universal Programmer User's Guide* or the KEYLOCK command in the *iPPS PROM Programming Software User's Guide* for information on programming the 27916 KEPROM authentication locations.

All of the above EPROM devices have an unprogrammed (blank) state of logic 1. Refer to the *Memory Components Handbook* for detailed technical information on programming these devices.

**Table 1 iUP-Fast 27/K PROM Device Support**

PROM Type	iUP-Fast 27/K	iUP-Fast 27/K-U1	iUP-Fast 27/K-U2
EPROM	2764 2764A 27128 27256	2764 2764A 27128 27128A 27256 27512 27513	2764 2764A 27C64 87C64 27128 27128A 27256 27C256 27512 27513
E <sup>2</sup> PROM		2817A	2817A
KEPROM			27916

**Table 2 27513 Page Addresses**

Page	27513 Address	Universal Programmer/ iPDS™ System Address
0	0 - 3FFF	0000 - 3FFF
1	0 - 3FFF	4000 - 7FFF
2	0 - 3FFF	8000 - BFFF
3	0 - 3FFF	C000 - FFFF

## iUP-FAST 27/K SOCKETS

The two 28-pin sockets are the program socket and the master socket (see Figure 2).

### Program Socket

The program socket is used for all operations on PROM devices less than or equal to 32K bytes and for all on-line operations. When using PROMs larger than 32K bytes (i.e., 27512) in off-line mode, you must have a master PROM in the master socket during all operations.

### Master Socket

The master socket is used only in off-line mode (iUP-201A universal programmer) and only for PROM devices greater than 32K bytes. Install the source PROM device in the master socket and the PROM device to be programmed in the program socket.

The master PROM is a buffer that you can modify with the iUP-201A universal programmer's DATA and FILL function keys. Refer to the *iUP-200A/201A Universal Programmer User's Guide* for more information on the off-line function keys.

## iUP-FAST 27/K INDICATORS

The ACTIVE SOCKET LED indicates when power is being applied to the PROM device(s) and when the host PROM programmer is accessing a socket(s).

After you enter the type of PROM to be programmed or read (using either the iUP-200A/201A universal programmer or the iPDS on-line TYPE command or the iUP-201A universal programmer off-line DEVICE SELECT key), the personality module's hexadecimal display shows the PROM device type selected. The numbers displayed correspond to the following PROM device types:

0 = 2764	1 = 2764A/27C64/87C64	2 = 27128
3 = 27128A	4 = 27256/27C256	5 = 27512
6 = 27513	7 = 2817A	8 = 27916

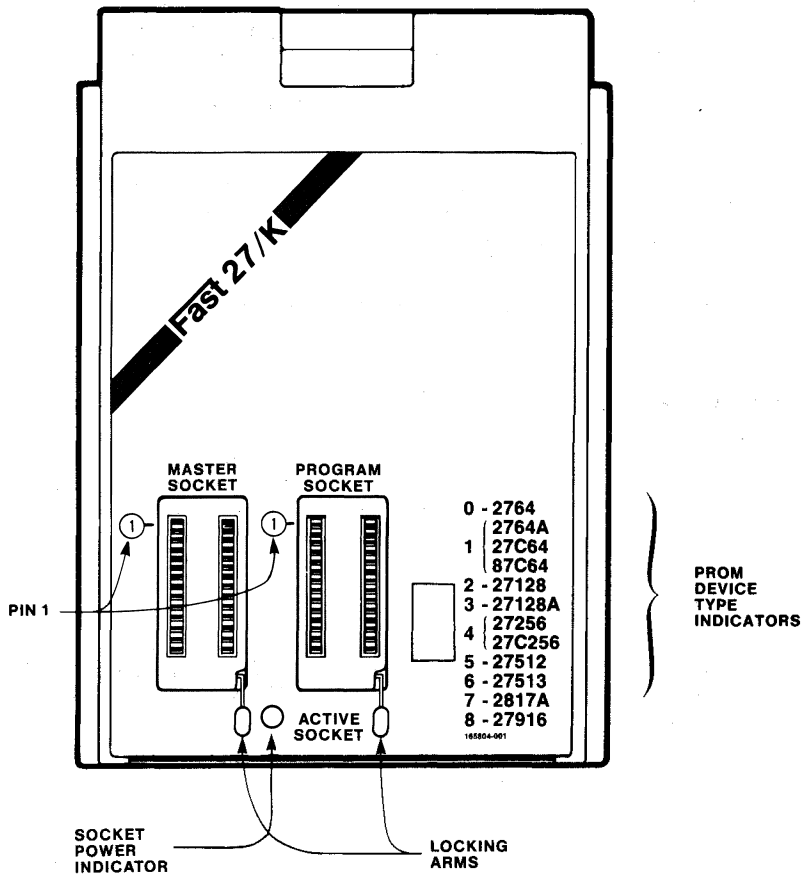

Figure 2 iUP-Fast 27/K Personality Module Indicators

**NOTE**

When using the personality module in on-line mode, enter 2764A to select PROM type 2764A, 27C64 or 87C64 and enter 27256 to select PROM type 27256 or 27C256.

Figure 2 shows the personality module indicators.

**UNPACKING AND INSPECTION**

Inspect the shipping carton immediately upon receipt for evidence of mishandling during transit. If the shipping carton is severely damaged or water-stained, request that the carrier's agent be present when the carton is opened. If the carrier's agent is not present when the carton is opened and the



contents of the carton are damaged, keep the carton and packing material for the agent's inspection. For repairs to a product damaged in shipment, contact the Intel product service hotline as described in the Service Information section.

Intel recommends that, if they are in good condition, the shipping carton and packing material be saved for storage and shipment of the product.

The personality module and the upgrade kit are shipped separately. After upgrading, the personality module is ready for installation as described in the Installation in the Universal Programmer or iPDS™ System section.

## INSTALLATION IN THE UNIVERSAL PROGRAMMER OR iPDS™ SYSTEM

The personality module plugs into the front panel connector of the universal programmer (see Figure 3) or the side door of the iPDS chassis (see Figure 4). No further connection is required. During installation and removal of the personality module, the universal programmer's or iPDS system's main power switch should be off.

### NOTE

Before installing the personality module, verify that it supports the PROM device type to be programmed or read.

## PROM DEVICE INSTALLATION

Perform the following steps to insert the PROM to be programmed or read.

### CAUTION

Do not switch the universal programmer's or iPDS system's power on or off when a PROM device is installed in a socket of the personality module. Damage to the PROM device may result.

1. If the universal programmer or iPDS system is not already powered on, switch on the power switch and wait for the initialization procedure to complete. The *iUP-200A/iUP-201A Universal Programmer User's Guide* describes universal programmer initialization, and the *iPDS™ Personal Development System User's Guide* describes the iPDS system initialization.

### CAUTION

Do not power on the system until you have read the powering on section in the *iUP-200A/201A Universal Programmer User's Guide* or the *iPDS™ Personal Development System User's Guide*.

2. Select the PROM type to be programmed or read, using either the TYPE command (during on-line operation) or the DEVICE SELECT key (during off-line operation). The hexadecimal display next to the PROM designations on the personality module indicates the PROM type selected.

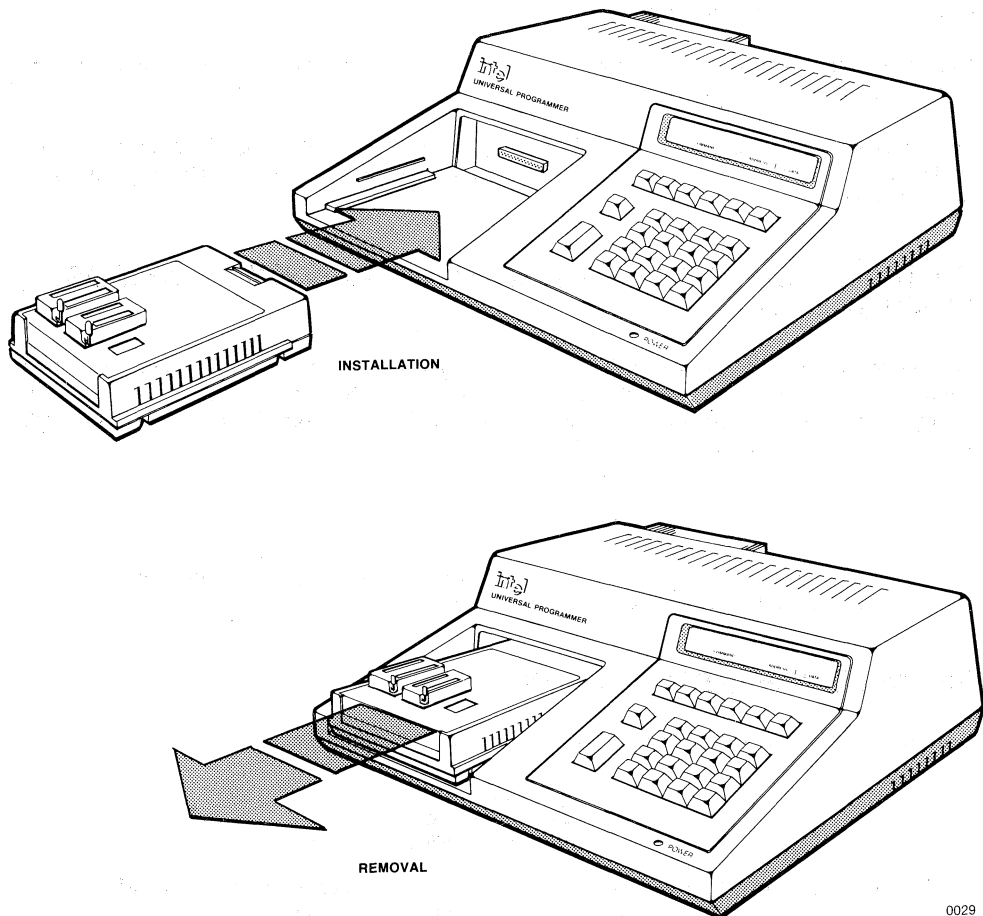

0029

**Figure 3 Installation in the Universal Programmer**

3. Raise the socket locking arm on the selected socket (see Figure 5).
4. Insert the device to be programmed into the socket. Pin 1 of the device must be inserted into the socket pin hole at the upper left corner of the socket. (Figure 2 shows the proper placement of pin 1.)

**CAUTION**

The orientation mark on one end of the PROM device must be toward the top of the socket. If a device is not oriented properly, it cannot be programmed and it may be damaged.

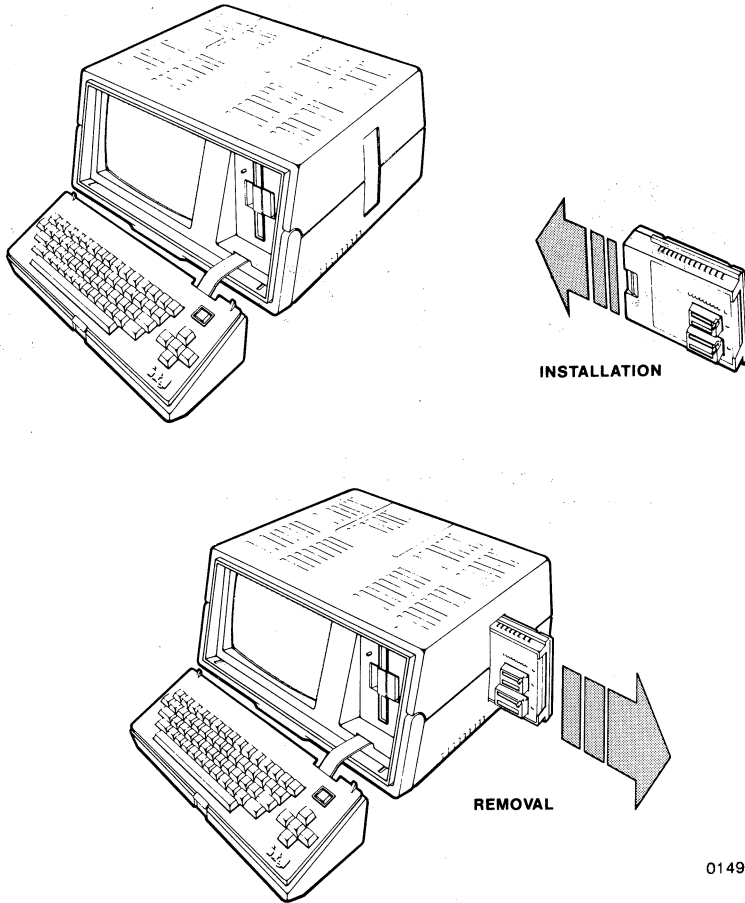

0149

**Figure 4 Installation in the iPDS™ Chassis**

When a device is oriented incorrectly in the program socket, the error message **CHECK PROM INSTALLATION** displays when the universal programmer or iPDS system tries to access the device. If a device is oriented incorrectly in the master socket or if the PROM device is installed in the program socket when it should be installed in the master socket, the error message **USE MASTER SOCKET** displays.

5. To secure the device in the socket, move the locking arm forward and down until it is parallel with the top of the personality module, as shown in Figure 5.

The PROM device is now ready for reading, programming, or verifying.

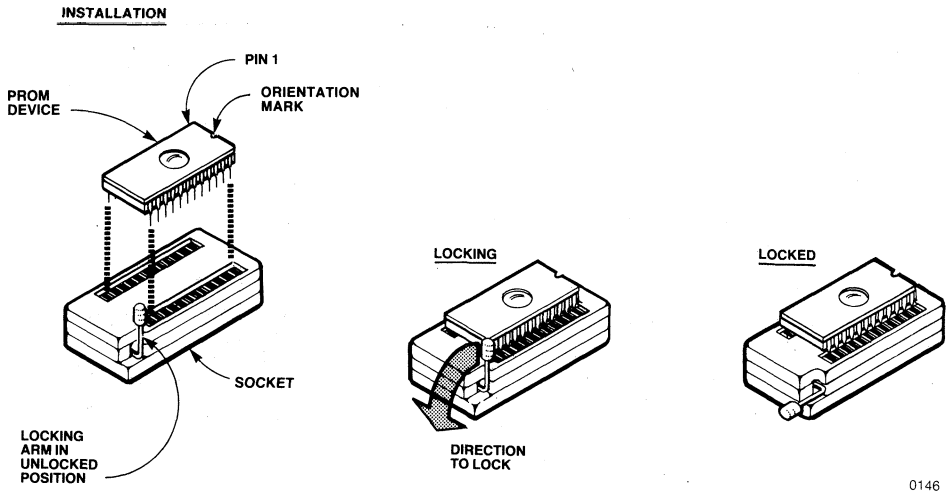

**Figure 5 PROM Device Installation**



## REQUEST FOR READER'S COMMENTS

Intel's Technical Publications Departments attempt to provide publications that meet the needs of all Intel product users. This form lets you participate directly in the publication process. Your comments will help us correct and improve our publications. Please take a few minutes to respond.

Please restrict your comments to the usability, accuracy, readability, organization, and completeness of this publication. If you have any comments on the product that this publication describes, please contact your Intel representative. If you wish to order publications, contact the Intel Literature Department (see page ii of this manual).

1. Please describe any errors you found in this publication (include page number).

---

---

---

---

2. Does the publication cover the information you expected or required? Please make suggestions for improvement.

---

---

---

---

3. Is this the right type of publication for your needs? Is it the right level? What other types of publications are needed?

---

---

---

---

4. Did you have any difficulty understanding descriptions or wording? Where?

---

---

---

---

5. Please rate this publication on a scale of 1 to 5 (5 being the best rating). \_\_\_\_\_

NAME \_\_\_\_\_ DATE \_\_\_\_\_  
TITLE \_\_\_\_\_  
COMPANY NAME/DEPARTMENT \_\_\_\_\_  
ADDRESS \_\_\_\_\_  
CITY \_\_\_\_\_ STATE \_\_\_\_\_ ZIP CODE \_\_\_\_\_  
(COUNTRY)

Please check here if you require a written reply.

**WE'D LIKE YOUR COMMENTS ...**

This document is one of a series describing Intel products. Your comments on the back of this form will help us produce better manuals. Each reply will be carefully reviewed by the responsible person. All comments and suggestions become the property of Intel Corporation.



**NO POSTAGE  
NECESSARY  
IF MAILED  
IN U.S.A.**

**BUSINESS REPLY MAIL**  
FIRST CLASS PERMIT NO. 79 BEAVERTON, OR

POSTAGE WILL BE PAID BY ADDRESSEE

**Intel Corporation  
5200 N.E. Elam Young Parkway.  
Hillsboro, Oregon 97123**

**DSHO Technical Publications**

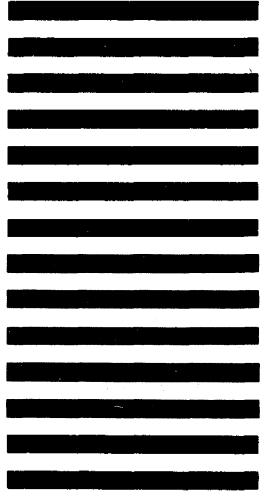





INTEL CORPORATION, 3065 Bowers Avenue, Santa Clara, California 95051 (408) 987-8080

Printed in U.S.A.

Development Systems